



instruction manual

Axcent³ and Axcent³ Pro

Integrated Access Controllers



Access Central Controllers

AMX Limited Warranty and Disclaimer

AMX Corporation warrants its products to be free of defects in material and workmanship under normal use for three (3) years from the date of purchase from AMX Corporation, with the following exceptions:

- Electroluminescent and LCD Control Panels are warranted for three (3) years, except for the display and touch overlay components that are warranted for a period of one (1) year.
- Disk drive mechanisms, pan/tilt heads, power supplies, and MX Series products are warranted for a period of one (1) year.
- AMX Lighting products are guaranteed to switch on and off any load that is properly connected to our lighting products, as long as the AMX Lighting products are under warranty. AMX Corporation does guarantee the control of dimmable loads that are properly connected to our lighting products. The dimming performance or quality cannot be guaranteed due to the random combinations of dimmers, lamps and ballasts or transformers.
- Unless otherwise specified, OEM and custom products are warranted for a period of one (1) year.
- AMX Software is warranted for a period of ninety (90) days.
- Batteries and incandescent lamps are not covered under the warranty.

This warranty extends only to products purchased directly from AMX Corporation or an Authorized AMX Dealer.

All products returned to AMX require a Return Material Authorization (RMA) number. The RMA number is obtained from the AMX RMA Department. The RMA number must be clearly marked on the outside of each box. The RMA is valid for a 30-day period. After the 30-day period the RMA will be cancelled. Any shipments received not consistent with the RMA, or after the RMA is cancelled, will be refused. AMX is not responsible for products returned without a valid RMA number.

AMX Corporation is not liable for any damages caused by its products or for the failure of its products to perform. This includes any lost profits, lost savings, incidental damages, or consequential damages. AMX Corporation is not liable for any claim made by a third party or by an AMX Dealer for a third party.

This limitation of liability applies whether damages are sought, or a claim is made, under this warranty or as a tort claim (including negligence and strict product liability), a contract claim, or any other claim. This limitation of liability cannot be waived or amended by any person. This limitation of liability will be effective even if AMX Corporation or an authorized representative of AMX Corporation has been advised of the possibility of any such damages. This limitation of liability, however, will not apply to claims for personal injury.

Some states do not allow a limitation of how long an implied warranty last. Some states do not allow the limitation or exclusion of incidental or consequential damages for consumer products. In such states, the limitation or exclusion of the Limited Warranty may not apply. This Limited Warranty gives the owner specific legal rights. The owner may also have other rights that vary from state to state. The owner is advised to consult applicable state laws for full determination of rights.

EXCEPT AS EXPRESSLY SET FORTH IN THIS WARRANTY, AMX CORPORATION MAKES NO OTHER WARRANTIES, EXPRESSED OR IMPLIED, INCLUDING ANY IMPLIED WARRANTIES OF MERCHANTABILITY OR FITNESS FOR A PARTICULAR PURPOSE. AMX CORPORATION EXPRESSLY DISCLAIMS ALL WARRANTIES NOT STATED IN THIS LIMITED WARRANTY. ANY IMPLIED WARRANTIES THAT MAY BE IMPOSED BY LAW ARE LIMITED TO THE TERMS OF THIS LIMITED WARRANTY.

Table of Contents

Product Information	1
Specifications	1
Installation	3
Installing Access Control Cards (Axcent3 Pro Only)	3
Installing the Axcent3 into an Equipment Rack	3
Installing the AC-RK3 Rack Kit.....	3
Installing the CSB Cable Support Bracket.....	4
Wiring the Axcent3	5
Preparing and connecting captive wires	5
RS-232/RS-422/RS-485 connections	6
Using the AXlink connector for data and power	6
Using the AXlink connector for data with a separate 12 VDC power supply.....	6
Relay connections.....	7
IR/SERIAL/DATA connections	7
Input/Output connections	7
Program connector (front and rear panels)	8
Access card slot connector (Axcent3 PRO only)	8
Access Programming	9
Device and Channel Numbers	9
Send_Commands for RS-232/422/485 Ports.....	9
Send_String Escape Sequences for RS-232/422/485 Ports.....	11
Send_Commands for IR/Serial/Data Ports.....	11
Send_Commands for Input/Output Ports	16
Standard IR Function Order	17
Program Port Commands.....	18
Xmodem Timing Commands.....	21
Setting PC-to-Axcess Program Communications, and a Controller's Device Number in Terminal Emulator Mode	21
Setting PC to Axcess Program Communications and Setting Device Number in Normal Mode.....	22
Axcess Master Mode.....	22
Replacing the Lithium Batteries	25
Updating Firmware	27
Configuration	27
Downloading Firmware.....	27

Product Information

The Axcent³ and Axcent³ Pro Integrated Access Controllers are multi-port Central Controllers that can be programmed to control RS-232/422/485, relay, IR/serial/data, and input/output devices. The Axcent³ Pro combines the multi-port functionality with 4 card slots that can be populated with Access Central Controller cards to accommodate system growth.

Specifications

The following table lists the specifications for the Axcent³ and Axcent³ Pro.

Specifications	
Dimensions (HWD):	
Axcent ³	3.47" x 17.0" x 3.0" (88.1 mm x 432 mm x 76.2 mm)
Axcent ³ Pro	3.47" x 17.0" x 13.65" (88.1 mm x 432 mm x 356.8 mm)
Weight:	
Axcent ³	2.5 lbs (1.1 kg)
Axcent ³ Pro	5.6 lbs (2.6 kg) without Access Control Cards
Power Requirement:	
Axcent ³	<ul style="list-style-type: none"> • 500 mA @ 12 VDC (all relays energized)
Axcent ³ Pro	<ul style="list-style-type: none"> • 550 mA @ 12 VDC (without Access control cards) (all relays energized)
Memory:	<ul style="list-style-type: none"> • Volatile memory: 128Kbx16 (user-modifiable) • Non-volatile memory: 256Kbx16 (user-modifiable)
Enclosure	Metal with black matte finish
Input buffer	128 bytes
Output buffer (AXlink)	128 bytes
Supported baud rates	300, 600, 1200, 2400, 4800, 9600, 19200, 38400
Max. length of SEND_STRING to device	64
Max. Length of data packets from device	64
Front Panel Components:	
PROGRAM port	DB-9 (male) connector for system programming
Status indicators	32 red LEDs showing port activity: <ul style="list-style-type: none"> • RS-232/422/485 - 6 receive LEDs and 6 transmit LEDs • Relay - 8 LEDs • IR/Serial/Data - 6 LEDs • I/O - 6 LEDs
AXlink indicator	Green LED shows AXlink data activity. Blink patterns include: <ul style="list-style-type: none"> • Off - No power, or the controller is not functioning properly • 1 blink per second - Normal operation. Device numbers match the programmed device numbers in the Access program. • 2 blinks per second - Device numbers do not match the Access program, a device is not present, or a device is not set to the right number. • 3 blinks per second - AXlink bus error. Check all AXlink bus connections. • Full On - Access program is not present and there is no AXlink activity
Slots 1 - 4	4 Access Control Card slots (Axcent ³ Pro only)
RS-232 Range:	50' (15.24 m) max.

Specifications (Cont.)	
Rear Panel Components:	
RS-232/RS-422/RS-485 ports	Six 9-pin (male) D-sub, RS-232/422/485 XON/XOFF, CTS/RTS, 300, 200 baud
Status indicators	32 red LEDs that show RS-232/422/485, relay, IR/Serial/Data, and I/O port activity. The LEDs light when data activity occurs on the associated ports.
AXlink indicator	Green LED showing power and AXlink data activity.
AXlink/PWR connector	4-pin connector for AXlink data and power, and 2-pin connector for external 12 VDC power supply
RELAYS connector	Two 8-pin connectors, 750 mA, 28 VAC/24 VDC (normally open)
IR/SERIAL/DATA connectors	12-pin (6 two-pins) male connector that supports IR, IR/Serial or one-way data communication (0 - 5 VDC levels only)
Input/Output connectors	8-pin connector, I/O 1 - 6, Common, +12 VDC power tap 200 mA, contact closure or TTL logic inputs
PROGRAM port	DB-9 (male) connector for system programming and diagnostics
Slots 1 - 4	Four 16-pin connectors for Access Control Cards (Axcent ³ Pro only)
Included Accessories:	<ul style="list-style-type: none"> • 4 CC-IRC emitters • Metal tab strip for commoning relays • Rack-mount brackets
Optional Accessories:	<ul style="list-style-type: none"> • 12 VDC power supply • CSB Cable Support Bracket • AC-RK3 Rack Kit • Access Control Cards (Axcent³ Pro only)

Installation

Installing Access Control Cards (Axcent³ Pro Only)

To install Access Control Cards:

1. Discharge the static electricity from your body, by touching a grounded object.
2. Remove the thumbscrews and faceplate from the front panel (FIG. 1).

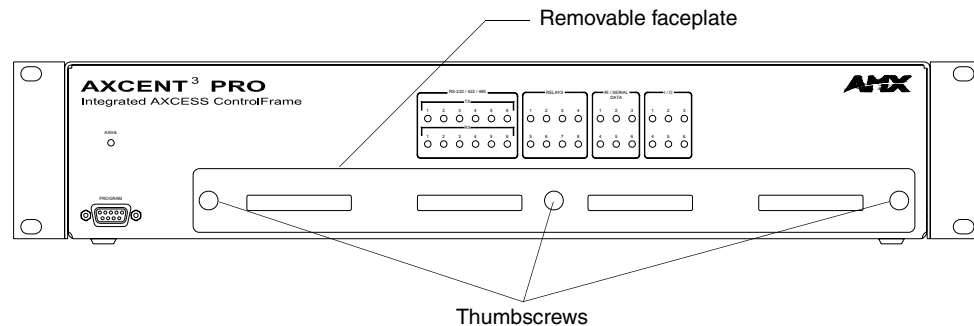

FIG. 1 Axcent³ Pro

3. Install up to 4 Access Control Cards component-side up into SLOT 1 - SLOT 4.
4. Replace the faceplate and secure with the thumbscrews.

Installing the Axcent³ into an Equipment Rack

Use the rack-mounting brackets supplied with each controller for equipment rack installations. Remove the mounting brackets for flat surface installations.

1. Discharge the static electricity from your body by touching a grounded object.
2. Place the controller into the equipment rack, and align the mounting bracket holes with the mounting holes on the equipment rack. Start the mounting screws on both sides of the controller and tighten.
3. Connect the data cables into the controller.
4. Connect the power cable to the AXLINK/PWR connector to power-up the controller.

Installing the AC-RK3 Rack Kit

Use the optional AC-RK3 Rack Kit for rear equipment rack rail installations or to place the controller 6 inches from the front/rear of the equipment rack. You need a Phillips-head screwdriver.

1. Discharge the static electricity from your body by touching a grounded object.
2. Remove the rack-mount brackets supplied with the controller.
3. Install the AC-RK3 brackets with the supplied Phillips-head screws. Align the bracket holes with the mounting brackets on the equipment rack. Then, start the mounting screws on both sides of the controller and tighten (see FIG. 2).

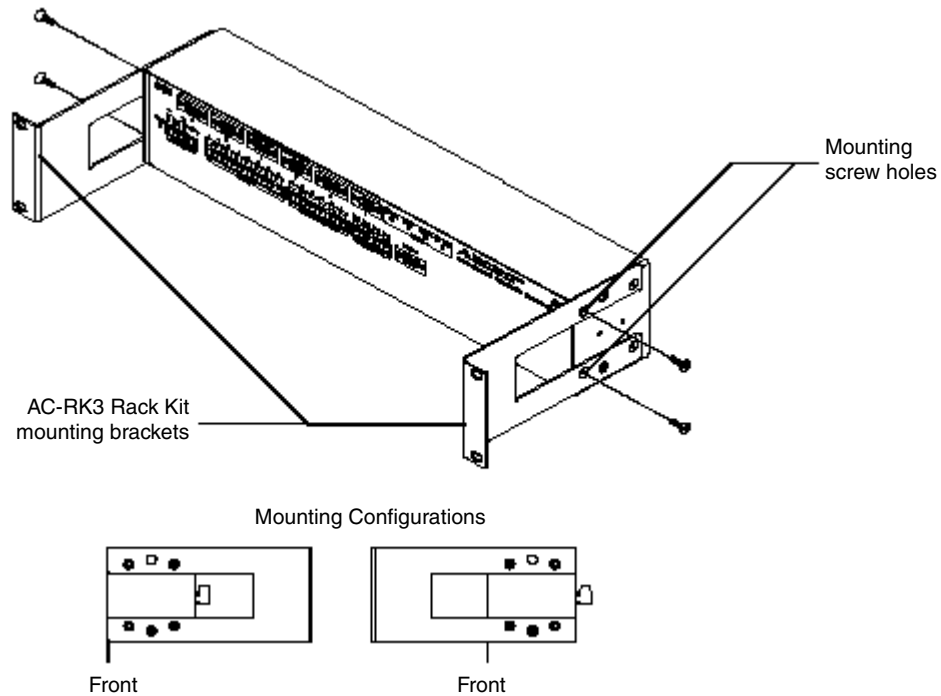

FIG. 2 AC-RK3 Rack Kit mounting diagram

4. Connect the data cables into the controller.
5. Connect the power cable to the AXLINK/PWR connector to power-up the controller.

Installing the CSB Cable Support Bracket

Install the optional CSB Cable Support Bracket to secure the power and data cables connected to the controller. You can use the CSB with the supplied rack mounting brackets or optional AC-RK3. You need a Phillips-head screwdriver.

1. Discharge the static electricity from your body by touching a grounded object.
2. Disconnect all (if applicable) power and data cables from the controller.
3. Hold the controller in place, and remove the mounting hardware from the equipment rack. Then, carefully remove the controller from the rack and place it onto a flat surface.
4. Install the CSB, as shown in FIG. 3.

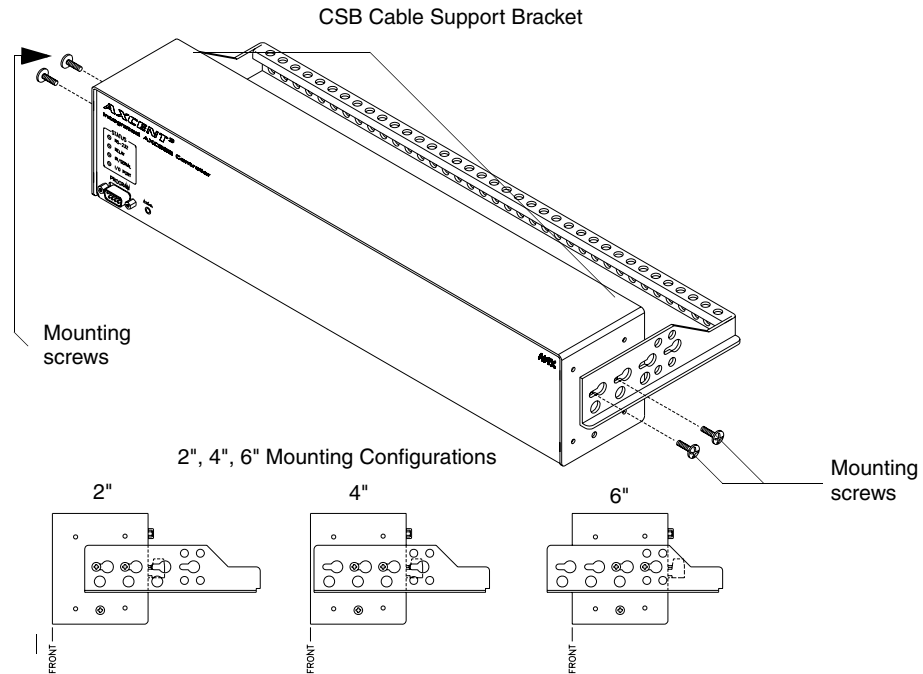

FIG. 3 CSB mounting diagram

5. Align the bracket holes with the mounting brackets on the equipment rack. Then, start the mounting screws on both sides of the controller and tighten.
6. Connect the data cables into the controller. Then, secure the data cables to the CSB.
7. Connect the power cable to the AXLINK/PWR connector to power-up the controller. Then, secure the cable to the CSB.

Wiring the Axcent³

Each connector you use to control external devices must be wired according to the information in this subsection.

Preparing and connecting captive wires

1. Strip 0.25 inch of wire insulation off all wires.
2. Insert each wire into the appropriate opening on the connector according to the wiring diagrams and connector types.
3. Turn the flat-head screws clockwise to secure the wire in the connector. Do not over-torque the screw; doing so can bend the seating pin and damage the connector.

RS-232/RS-422/RS-485 connections

FIG. 4 shows the RS-232/RS-422/RS-485 DB-9 (male) connector pinouts. The table below lists the connector pins, signal types, and signal functions.

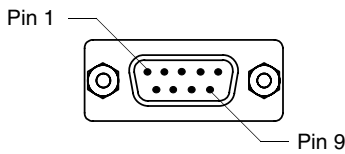

FIG. 4 RS-232/422/485 DB-9 (male) connector pinouts

DB-9 Pinouts			Wiring and Baud Configurations		
Pin	Signal	Function	RS-232	RS-422	RS-485
1	RX-	Receive data		X	X (strap to pin 9)
2	RXD	Receive data	X		
3	TXD	Transmit data	X		
4	TX+	Transmit data		X	X (strap to pin 6)
5	GND	Signal ground	X	X	
6	RX+	Receive data		X	X (strap to pin 4)
7	RTS	Request to send	X		
8	CTS	Clear to send	X		
9	TX-	Transmit data		X	X (strap to pin 1)

The X's show where to terminate the wires on the DB-9 connector.

Using the AXlink connector for data and power

Connect the 4-pin AXlink connector to an external AXlink device, as shown in FIG. 5.

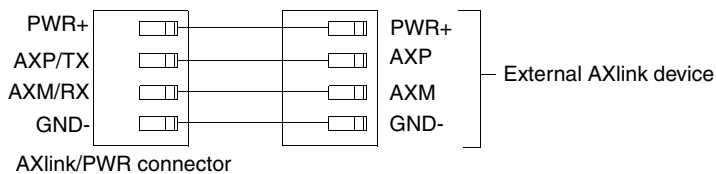

FIG. 5 AXlink/PWR data and power wiring diagram

Using the AXlink connector for data with a separate 12 VDC power supply

Connect the 4-pin AXlink connector to an external AXlink device; connect the 2-pin PWR connector to the separate 12 VDC power supply as shown in FIG. 6. Make sure to connect only the

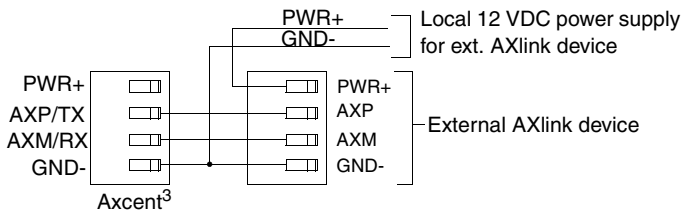

FIG. 6 AXlink/PWR and optional 12 VDC power supply wiring diagram

GND wire on the AXlink/PWR connector when using a separate 12 VDC power supply. Do not connect the PWR wire to the AXlink connector's PWR (+) opening.

Relay connections

Connect up to eight independent external relay devices to the 16-pin RELAYS connector. Use A for common and B for output. Each relay is isolated and normally open. A metal connector strip is also provided to common multiple relays.

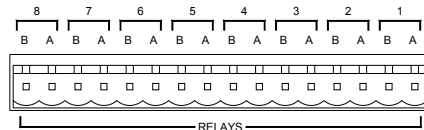

FIG. 7 RELAY 16-pin connector

IR/SERIAL/DATA connections

Connect up to six IR, IR/Serial, and/or DATA (transmit only, 0 - 5 VDC levels only) devices to the 12-pin IR/SERIAL/DATA connector shown in FIG. 8. You can connect a CC-IRC Infrared Emitter, external serial device with a 2-pin captive-wire. You can also connect a data 0 - 5 VDC device.

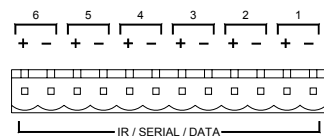

FIG. 8 IR/SERIAL/DATA 12-pin connector

Input/Output connections

Connect up to six Input/Output (I/O) devices to the INPUT/OUTPUT 8-pin connector, as shown in *INPUT/OUTPUT 8-pin (male) connector* section on page 7. A contact closure between GND and an I/O port is detected as a PUSH. When used for a voltage input, the I/O port detects a low (0 - 1.5 VDC) as a PUSH, and a high signal (3.5 - 5 VDC) as a RELEASE. When used for an output, each I/O port acts as a switch to GND and is rated at 200 mA @ 12 VDC.

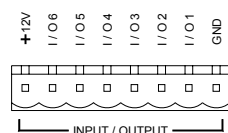

FIG. 9 INPUT/OUTPUT 8-pin (male) connector

- **+12V** - 12 VDC power output for PCS Power Current Sensors, VSS2 Video Sync Sensors, or similar I/O-type equipment
- **I/O 1 - 6** - Six I/O ports
- **GND** - Common ground shared with I/O ports 1 - 6

Program connector (front and rear panels)

Connect a programming cable to the PROGRAM connector on the controller. The table below shows the DB-9 connector pins and signals for the PROGRAM connector. Use the PROGRAM connector to download Access programs, and to set up control communication options using the OpenAccess software program.

Program Connector and Pinouts	
Pin	Signal
2	RXD
3	TXD
4	+12 VDC
5	GND
7	+12 VDC

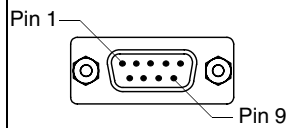

PROGRAM pins 1, 6, 8, and 9 are not used. Pins 4, 5, and 7 are for an ALF Programming Unit.

Access card slot connector (Axcent³ PRO only)

FIG. 10 shows the 16-pin (male) connector that provides connection to the Access Control Cards. After installing control cards, refer to the literature provided with the control card for wiring and Access programming information.

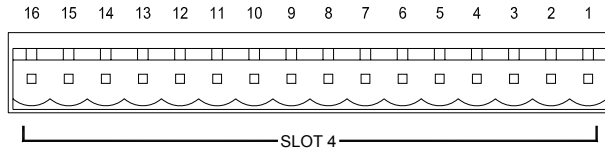

FIG. 10 Access Control Card 16-pin connector

Access Programming

Device and Channel Numbers

The following table lists the port type, device numbers, channels, with a brief description.

Device and Channel Number Parameters			
Port Type	Device Numbers	Channels	Description
RS-232/422/485	1 - 6	1 - 255	6 Rs-232/422/485 control ports with XON/XOFF (transmit on/transmit off), and CTS/RTS (clear to send/ready to send), 300, 200 baud.
Relay	7	1 - 8	8-channel relay ports
IR/Serial/Data	8 - 13	1 - 254	6 IR/Serial/Data control ports that support high-frequency carriers up to 1.14 MHz, and one-way data, 300 - 38,400 baud (0 - 5 VDC)
Input/Output	14	1 - 6	6-channel I/O port for contact closure, 0 - 5 VDC voltage sensing, or interactive power sensing for IR ports
Access Control Cards	15 - 18	Card dependent	Card slots 1 - 4 (Axcent ³ Pro only)

Send_Commands for RS-232/422/485 Ports

The table below lists the Send_Commands for the internal RS-232/422/485 ports.

Send_Commands for RS-232/422/485 Mode	
B9MOFF Sets the port's communication parameters.	Sets the parameters for stop and data bits according to the software settings on the RS-232 port (default). Syntax: ' B9MOFF ' Example: SEND_COMMAND RS232_1, ' B9MOFF ' Sets the RS-232 port settings to match the port's configuration settings.
B9MON Overrides the communication settings on the RS-232 port.	Overrides settings to 9 data bits and 1 stop bit, and use the port's active baud rate settings. Example: SEND_COMMAND RS232_1, ' B9MON ' Resets the RS-232 port's communication parameters to 9 data bits, 1 stop bit, and locks-in the baud rate set with the OpenAccess software program.
CHARD Sets the delay time between transmitted characters.	Syntax: ' CHARD-<0-255> ' Variables: <0 - 255> = time in 100 microsecond increments Example: SEND_COMMAND RS232_1, ' CHARD-100 ' Sets 10 millisecond delay between all transmitted characters.

Send Commands for RS-232/422/485 Mode (Cont.)	
CTSPSH Enables Pushes, Releases, and status information to send to the Program via channel 255.	Syntax: 'CTSPSH' Example: SEND_COMMAND RS232_1, 'CTSPSH' Sets the RS232_1 port to detect changes on the CTS input.
DE Sets the minimum delay time before controller detects/ responds to a contact closure and performs a programmed operation.	A contact closure is sometimes called a debouncing circuit. Syntax: " 'DE', <Delay> " Variables: <Delay> = 0 - 255 in tenths of a second Example: SEND_COMMAND IR_1, " 'DE', 20 " Sets the IR_1 port's minimum linked input stabilization time to 2 seconds.
Set Baud Set the RS-232/422/485 port's communication parameters.	Syntax: 'SET BAUD (Baud), (Parity), (Data), (Stop), [485 (DISABLE/ENABLE)] ' Variables: Baud = 300, 600, 1200, 2400, 4800, 9600, 19200, 38400 or AUTO Parity = N (none), O (odd), E (even), M (mark), S (space) Data = 7 or 8 data bits Stop = 1 or 2 stop bits Disable = disables RS-485 mode, and enables RS-422 Enable = enables RS-485 mode, and disables RS-422 Example: SEND_COMMAND RS232_1, 'SET BAUD 9600,N,8,1,485 ENABLE ' Sets the RS232_1 port's communication parameters to 9,600 baud, no parity, 8 data bits, 1 stop bit, and enables RS-485 mode.
Get Baud Gets the RS-232/422/485 port's current communication parameters.	The port sends the data through the master's PROGRAM port. Syntax: 'GET BAUD ' Example: SEND_COMMAND RS232_1, 'GET BAUD ' System response example: Device 1, 38400,N,8,1 485 DISABLED
'HSOFF'	Disables hardware handshaking (default).
'HSON'	Enables hardware handshaking.
'RXCLR'	Clears all characters in the receive buffer waiting to be sent to the master.
'RXOFF'	Stops transmitting received characters to the master.
'RXON'	Transmits received characters to the master. The CREATE_BUFFER Access keyword automatically sends the RXON command to the device.
'TXCLR'	Clears and stops all characters waiting in the transmit buffer.
'XOFF'	Disables software handshaking (default).
'XON'	Enables software handshaking.

Send_String Escape Sequences for RS-232/422/485 Ports

The table below lists the Send_String escape sequences for the RS-232/422/485 ports.

Send_String Escape Sequences for RS-232/422/485 Ports	
"27,17,<1-255>"	Sends a break character for the specified length of time. Variables: 1 - 255 = time in 100 microsecond increments
"27,18,1"	Sets the ninth data bit to 1 for all subsequent characters transmitted. Use this escape sequence with the 'B9MON' command.
"27,18,0"	Clears the ninth data bit to 0 for all subsequent characters transmitted. Use this escape sequence with the 'B9MON' command.
"27,19,<1-255>"	Inserts delay time before the next character transmits. Variables: 1 - 255 = time in 1 microsecond increments.
"27,20,0"	Sets RTS hardware handshake's output high.
"27,20,1"	Sets RTS hardware handshake's output low.

Send_Commands for IR/Serial/Data Ports

The IR/Serial/Data Send_Commands listed in the table below generate control data for external device, and also configure the IR/Serial/Data ports.

Send_Commands for the IR/Serial/Data Ports	
CAROFF Disables carrier from responding until a CARON command is received.	This command overrides active software settings. Syntax: 'CAROFF' Example: SEND_COMMAND IR_1, 'CAROFF' Stops transmitting the IR carrier signal.
CARON Enables the carrier to respond according to active software settings.	Syntax: 'CARON' Example: SEND_COMMAND IR_1, 'CARON' Starts transmitting the IR carrier signal.

Send Commands for the IR/Serial/Data Ports (Cont.)	
<p>CH Generates IR digit pulses to select a television channel number.</p>	<p>Channels 1-99 pulse as two digits. Channels 100 and greater, the one-hundredth digit pulses as 127. If IR function 21 (enter) exists, it follows the IR digit pulses. CTON sets the pulse length for each digit and CTOF sets the time between each digit or any other pulse.</p> <p>Syntax: " 'CH', <channel> "</p> <p>Variables: <channel> = 0 - 199</p> <p>Example: SEND_COMMAND IR_1, " 'CH', 18 "</p> <p>The controller performs the following:</p> <ul style="list-style-type: none"> • Transmits IR pulses for 1 (IR code 11) for the time set by CTON. • Waits for the time set by CTOF. • Transmits IR pulses for the IR code for 8 (IR code 18) for the time set by CTON. • Waits for the time set by CTOF. If the IR code for ENTER (IR code 21) is programmed, steps 5 and 6 are performed. • Transmits IR pulses for ENTER (IR code 21) for the time set by CTON. • Waits for the time set by CTOF.
<p>CP Transmits IR code pulses and clear all commands in the buffer.</p>	<p>This command pulses the actual IR code. Pulse time is set by the CTON and CTOF commands.</p> <p>Syntax: " 'CP', <channel> "</p> <p>Variables: <channel> = 0 - 252</p> <p>Example: SEND_COMMAND IR_1, " 'CP', 2 "</p> <p>Clears pending commands and pulses command number 2.</p>
<p>CTOF Sets the single IR pulses off time between channel digits and IR functions.</p>	<p>CTOF sets the time between digits or any other pulse and CTON sets the pulse length for each digit. This is the time between digits, or pulses, that is associated with an SP command.</p> <p>Syntax: " 'CTOF', <time> "</p> <p>Variables: <time> = 0 - 255 in tenths of a second; Time is stored in permanent memory. System default is 5 (.5 second).</p> <p>Example: SEND_COMMAND IR_1, " 'CTOF', 10 "</p> <p>Sets the channel's off-time pulse in tenths of a second. Default time is 5 (0.5 second). Time is stored in non-volatile RAM.</p>

Send Commands for the IR/Serial/Data Ports (Cont.)	
<p>CTON Sets the IR pulse (single) on time for each channel digit and IR functions.</p>	<p>CTON sets the pulse length for each digit and CTOF sets the time between digits or any other pulse. Syntax: " 'CTON', <time> " Variables: <time> = 0 - 255 in tenths of a second; Time is stored in permanent memory. System default is 5 (.5 second). Example: SEND_COMMAND IR_1, " 'CTON', 20 " Sets the pulse length to 2 seconds.</p>
<p>GET BAUD Gets the IR/Serial/Data port's current communication parameters.</p>	<p>The port sends the data through the master's PROGRAM port. Syntax: 'GET BAUD ' Example: SEND_COMMAND IR_1, 'GET BAUD ' System response example: Device 1,38400,N,8,1</p>
<p>GET MODE Gets the IR/Serial/Data port's current mode setting.</p>	<p>Syntax: 'GET MODE ' Example: SEND_COMMAND IR_1, 'GET MODE ' System response example: Device 8 IR,CARRIER,IO LINK 0</p>
<p>IROFF Stops IR output on the designated device.</p>	<p>Syntax: 'IROFF ' Example: SEND_COMMAND IR_1, 'IROFF ' Stops transmitting IR signals.</p>
<p>POD</p>	<p>Syntax: 'POD ' Disables current PON (power on) or POF (power off) command settings. Channel 255 changes are enabled.</p>
<p>POF</p>	<p>Syntax: 'POF ' Sends IR function 28 (if available) or 9 to turn device power off. After three attempts, if the linked I/O channel still detects a power-on status, the controller starts processing stored buffer commands. Then, if another IR function 28 or 9 fails to turn the external device's power off, the controller sends a PUSH and RELEASE of channel 248 and generates a power failure error. If the device is turned on manually, this command turns the external device's power off unless a PON (power on) or POD (disable POF) command is received. Refer to the SET IO LINK command.</p>
<p>PON</p>	<p>Syntax: 'PON ' Sends IR function 27 (if available) or 9 to turn device power on. After three attempts, if the linked I/O channel still detects a power-off status, the controller starts processing stored buffer commands. Then, if another IR function 27 or 9 fails to turn the external device's power on, the controller sends a PUSH and RELEASE of channel 248 and generates a power failure error. If the device is turned off manually, this command turns external device power on unless a POF (power off) or POD (disable 'PON' command) command is received.</p>

Send Commands for the IR/Serial/Data Ports (Cont.)	
<p>PTOF Sets IR power-off pulse time after a power-on pulse in increments of .10 seconds.</p>	<p>Syntax: " 'PTOF', <time>"</p> <p>Variables: <time> = 0 - 255; Time is stored in permanent memory. System default is 15 (1.5 seconds).</p> <p>Example: SEND_COMMAND 55, " 'PTOF', 15"</p> <p>Sets the power-off pulse time after a power-on pulse to 1.5 seconds for device 55.</p>
<p>PTON Sets the IR power-on pulse time after a power-off pulse in increments of .10 seconds.</p>	<p>Syntax: " 'PTON', <time>"</p> <p>Variables: <time> = 0 - 255; Time is stored in permanent memory. System default is 15 (1.5 seconds).</p> <p>Example: SEND_COMMAND 55, " 'PTON', 15"</p> <p>Sets the power-off pulse time after a power-on pulse to 1.5 seconds for device 55.</p>
<p>SET BAUD Sets the IR/Serial/Data port's communication parameters.</p>	<p>Syntax: 'SET BAUD (Baud), (Parity), (Data), (Stop)'</p> <p>Variables: Baud = 300 - 38,400 Parity = N (none), O (odd), E (even) Data = 7 or 8 data bits Stop = 1 stop bit</p> <p>Example: SEND_COMMAND IR_1, 'SET BAUD 9600,N,8,1'</p> <p>Sets the IR_1 port's communication parameters to 9,600 baud, no parity, 8 data bits, and 1 stop bit.</p>
<p>SET MODE Sets the IR/Serial/Data port for IR-, Serial-, or Data-controlled devices that connect to the port.</p>	<p>Syntax: 'SET MODE (MODE)'</p> <p>Variables: Mode = IR, SERIAL, or DATA</p> <p>Example: SEND_COMMAND IR_1, 'SET MODE IR'</p> <p>Sets the IR_1 port to IR mode so that an IR-controlled device can be connected to the port.</p>
<p>SET IO LINK Links an IR/Serial/Data port to an input/output (I/O) channel for use with PON and POF commands.</p>	<p>The I/O channel can sense 0-5 VDC using a PCS or PCS2 Power Current Sensor. Set the I/O channel to 0 to disable the link function.</p> <p>Syntax: 'SET MODE (MODE)'</p> <p>Example: SEND_COMMAND IR_1, 'SET IO LINK 1'</p> <p>Sets the IR_1 port link to I/O port 1. The IR port uses the specified I/O input as power status for processing PON and POF commands.</p>

Send Commands for the IR/Serial/Data Ports (Cont.)	
<p>SP Generates a single <IR out> function pulse.</p>	<p>The CTON sets pulse length and CTOF sets time between pulses.</p> <p>Syntax: " 'SP', <IR out> "</p> <p>Variables: <IR out> = 1 - 127</p> <p>Example: SEND_COMMAND IR_1, " 'SP', 25 "</p> <p>Pulses IR code 25, which decreases the volume level on the equipment connected to the controller.</p>
<p>XCH Transmits the IR code in the format set with the XCHM mode command.</p>	<p>Syntax: 'XCH [channel] '</p> <p>Variables: <channel> = 0 - 999</p> <p>Mode 0 (default) Example: SEND_COMMAND IR_1, 'XCH 3 ' Transmits the IR code as 3 enter. SEND_COMMAND IR_1, 'XCH 34 ' Transmits the IR code as 3 4 enter. SEND_COMMAND IR_1, 'XCH 343 ' Transmits the IR code as 3 4 3 enter.</p> <p>Mode 1 Example: SEND_COMMAND IR_1, 'XCH 3 ' Transmits the IR code as 0 0 3 enter. SEND_COMMAND IR_1, 'XCH 34 ' Transmits the IR code as 0 3 4 enter. SEND_COMMAND IR_1, 'XCH 343 ' Transmits the IR code as 3 4 3 enter.</p> <p>Mode 2 Example: SEND_COMMAND IR_1, 'XCH 3 ' Transmits the IR code as 0 0 3. SEND_COMMAND IR_1, 'XCH 34 ' Transmits the IR code as 0 3 4. SEND_COMMAND IR_1, 'XCH 343 ' Transmits the IR code as 3 4 3.</p> <p>Mode 3 Example: SEND_COMMAND IR_1, 'XCH 3 ' Transmits the IR code as 0 3. SEND_COMMAND IR_1, 'XCH 34 ' Transmits the IR code as 3 4. SEND_COMMAND IR_1, 'XCH 343 ' Transmits the IR code as 100 100 100 4 3.</p>

Send_Commands for the IR/Serial/Data Ports (Cont.)	
<p>XCHM Sets the IR output format on the channel specified with the XCH command.</p>	<p>Syntax: 'XCHM [channel mode]'</p> <p>Variables: channel mode = Mode 0 - 3: Mode 0: [x][x]<x><enter> (default) Mode 1: <x><x><x><enter> Mode 2: <x><x><x> Mode 3: [[100][100]...]<x><x></p> <p>Example: SEND_COMMAND IR_1, 'XCHM-3 '</p> <p>Sets the XCH [Channel] extended channel command to mode 3. Refer to the XCH command for additional programming examples.</p>

Send_Commands for Input/Output Ports

The table below lists the I/O Send_Commands that set the I/O ports on the controller.

Send_Commands for Input/Output Ports	
<p>SET INPUT Sets the input channel's active state.</p>	<p>An active state can be high (logic high) or low (logic low or contact closure). Channel changes, pushes, and releases generate reports based on their active state.</p> <p>Syntax: 'SET INPUT (Port) (State)'</p> <p>Variables: Port = 1-6 Sate = High or Low</p> <p>Example: SEND_COMMAND IO, 'SET INPUT 1 HIGH'</p> <p>Sets I/O port to detect a high state change.</p>
<p>GET INPUT Gets the input channel's active state.</p>	<p>An active state can be high (logic high) or low (logic low or contact closure). Channel changes, pushes, and releases generate reports based on their active state.</p> <p>Syntax: 'GET INPUT (Port)'</p> <p>Variables: Port = 1-6</p> <p>Example: SEND_COMMAND IO, 'GET INPUT 1'</p> <p>Gets I/O port's active state.</p>

Standard IR Function Order

The table below lists the standard function order for IR codes. Refer to the *IRLIB* instruction manual to download IR files.

Standard IR Function Order			
Function	Description	Function	Description
1	Play >	22	Channel up or +
2	Stop []	23	Channel down or -
3	Pause or still	24	Volume up or +
4	Ffwd >> (AMS/skip/track/ chapter)	25	Volume down or -
5	Rewind << (AMS/skip/track/ chapter)	26	Mute
6	Search fwd >> (AMS/scan)	27	On (power typically)
7	Search rev << (AMS/scan)	28	Off (power typically)
8	Record	29	TV/Video or TV/VCR or TV/LDP (one button source selection)
9	Power or on/off	30	TV
10	'0' or '10'	31	Video1, Line A, VCR1, VDP, or input +
11	'1' (channel digits or tracks for CD)	32	Video2, LineB, VCR2, or input -
12	'2'	33	Video3
13	'3'	34	RGB1 or Tape1
14	'4'	35	RGB2, or Tape2
15	'5'	36	CD
16	'6'	37	Tuner
17	'7'	38	Phono
18	'8'	39	AUX
19	'9'	40	AM/FM
20	'+10' or '+100'	41	Play < (play reverse)
21	Enter (used in conjunction with numbers typically)	42	A/B

Program Port Commands

The PROGRAM port commands listed in the table below perform a wide variety of operations. You will need to connect an programming cable to the PROGRAM port on a master or slave controller, and your PC's serial port. The Controllers column shows the commands that can be used with Central controllers.

PROGRAM Port Commands		
Command	Function	Description
COMPARE DEVICE	Master	The controller returns a list of all devices that it detects as missing from the AXlink bus and then a list of all the extra devices. The controller compares the devices present on the AXlink bus against the devices listed in the Define_Device section in the controller's Access program. Syntax: COMPARE DEVICE
DATE	Master	The controller returns the current date and day of the week set in the controller. Syntax: DATE
DEVICE STATUS	Master	Syntax: DEVICE STATUS <Device Number> The controller returns a list of all activated (on) channels in the specified device.
ECHO OFF	Master and Slave	Disables terminal character's echo function. Syntax: ECHO OFF
ECHO ON	Master and Slave	Enables terminal character's echo function. Syntax: ECHO ON
HAVE CONTROL	Master	The controller reports if it is currently controlling AXlink. The controller stays in control if a valid system program is running, unless there is another redundant controller present. If the controller is not in control of AXlink, it may not contain a program, there are AXlink wiring problems, or the backup controller (if present) is in control. The green LED on the controller also shows indication of AXlink control. Syntax: HAVE CONTROL
HAVE PROGRAM	Master	The controller reports if it currently has a system program in memory. Syntax: HAVE PROGRAM
HELP	Master and Slave	Displays online help menu. Syntax: HELP
LEDON	Master and Slave	The 32 LEDs will light for approximately two seconds. This command is used for hardware test purposes. Syntax: LEDON
MEMORY	Master	Displays total memory equipped in the controller. Syntax: MEMORY

PROGRAM Port Commands (Cont.)		
OFF	Master	<p>Turns the device and channel numbers off.</p> <p>Syntax:</p> <pre>OFF [Device, Channel]</pre> <p>Variables:</p> <p>Device = 1 - 255 Channel = 1 - 255</p> <p>Example:</p> <pre>>OFF [52,1]</pre> <p>Turns channel 1 on device 52 off.</p>
ON	Master	<p>Turns the device and channel numbers on.</p> <p>Syntax:</p> <pre>ON [Device, Channel]</pre> <p>Variables:</p> <p>Device = 1 - 255 Channel = 1 - 255</p> <p>Example:</p> <pre>>ON [25,1]</pre> <p>Turns channel 1 on device 25 on.</p>
PASS	Master	<p>Syntax:</p> <pre>PASS <Device Number></pre> <p>This command communicates across the AXlink bus to external devices. When the PASS mode is enabled, all characters sent to the controller are passed along to the specified device, and all characters received from the device travel to the controller and then out of the card's port. To exit from the PASS mode, type the following while holding down the <Shift> key (<ESC> is the Escape key):</p> <pre>++ <Esc> <Esc></pre>
PULSE	Master	<p>Pulse the device and channel numbers.</p> <p>Syntax:</p> <pre>PULSE [Device, Channel]</pre> <p>Variables:</p> <p>Device = 1 - 255 Channel = 1 - 255</p> <p>Example:</p> <pre>>PULSE [16,1]</pre> <p>Pulses channel 1 on device 16.</p>
SEND_COMMAND	Master	<p>Send commands to the specified device. Refer to the device's literature for programming.</p> <p>Syntax:</p> <pre>SEND_COMMAND <Device>, String</pre> <p>Variables:</p> <p>Device = 1 - 255</p>
SEND_STRING	Master	<p>Send strings to the specified device. Refer to the device's literature for programming.</p> <p>Syntax:</p> <pre>SEND_STRING <Device>, String</pre> <p>Variables:</p> <p>Device = 1 - 255</p>

PROGRAM Port Commands (Cont.)		
SET BASE DEVICE NUMBER	Master and Slave	Sets the AXlink base device number on the controller's RS-232 port 1. Subsequent ports on the controller are incrementally set. If the device number is 1, the controller becomes an AXlink bus master, and if the device number is set to 2-xxx, the controller becomes a slave. Syntax: SET BASE DEVICE NUMBER <Device> Variables: Device = 1 - 238
SET DATE	Master	Changes the date in the controller. Syntax: SET DATE
SET TIME	Master	Changes the time in the controller. Syntax: SET TIME
SHOW DEVICE	Master	Displays a list of all devices present on the AXlink bus. Syntax: SHOW DEVICE
SHOW INPUT OFF	Master	Sets Show Input mode off. Syntax: SHOW INPUT OFF
SHOW INPUT ON	Master	Sets Show Input mode on. Syntax: SHOW INPUT ON
SLOT	Master	The active controller returns its slot number. Syntax: SLOT
SYSTEM RESET	Master	The controller stops communication on AXlink for 2 seconds and then restarts. The system program then restarts according to the Define_Start section. Syntax: SYSTEM RESET
TIME	Master	The controller returns the time in its internal clock. Syntax: TIME
VERSION	Master and Slave	Displays current software version of the controllers. Syntax: VERSION

Xmodem Timing Commands

The table below lists the Axcent³ and Axcent³ Pro Xmodem timing commands. Xmodem timeouts and retries exist to accommodate potential Ethernet delays and for consistency among and within products.



NOTE

Any of the Timeout commands will change timing for Access code download as well as SOFTROM transfer.

Any of the Retry commands will change the number of retries for Access code download as well as SOFTROM transfer.

Xmodem Timing Commands	
Xmodem timeouts (Default is 10 sec.)	
'TIMEOUT XX'	Via the Program Port.
SEND_COMMAND 0, 'XMTO XX'	Over AXlink, where 0 is the device number. Where XX is from 1 - 50 seconds in 1-second increments.
SEND_COMMAND 1, 'XMTO XX'	Over AXlink, where 1 is the device number. Where XX is from 1 - 50 seconds in 1-second increments.
Xmodem retries (Default is 5)	
'RETRY XX'	Via the Program Port.
SEND_COMMAND 0, 'XMRT XX'	Over AXlink, where 0 is the device number. Where XX is from 1 - 10 in increments of 1.
SEND_COMMAND 1, 'XMRT XX'	Over AXlink, where 1 is the device number. Where XX is from 1 - 10 in increments of 1.

Setting PC-to-Access Program Communications, and a Controller's Device Number in Terminal Emulator Mode

Follow these instructions to set PC-to-Access program communications, and the controller's base device number. The only time you need to perform these steps is to download an Access program the first time, or to reset a controller back to a master.

1. Connect a programming cable to the PROGRAM connector on the controller, and to the serial port on your PC.
2. Launch the AccessX program to open the main window.
3. Press F4 to open the Communications drop-down menu, and select Configure.
4. Press ENTER. Reset the communication parameters so that they match the controller's communication settings. Press F10 to save the new settings and close the CONFIGURE menu. When AXlink communication is established between the controller and PC, the AX Present message appears in the lower left-hand corner of the Access main window.



NOTE

You set options in the CONFIGURE window by placing the cursor next to the option using the directional keys, and pressing Enter. A check mark will appear next to each option you set.

5. Press F4 again to open the Communications drop-down menu. Choose the Terminal emulator option to open the Terminal window. You can also press CTRL and T to open the window.

6. Press ENTER four times to lock-in the communication settings. Now, you can download an Access program to the controller. Choose one of the following modes to set:
 - To reset the controller's base device number, type SET BASE DEVICE NUMBER 1.
 - To display everything you type in the Terminal window, type Echo On to activate echo mode.

Setting PC to Access Program Communications and Setting Device Number in Normal Mode

Follow these instructions to set PC-to-Access program communications, and the controller's base device number. The following procedure is based upon having an existing Access program file that is ready to be downloaded.

1. Press F1 to open the File menu, select Change directory, type the directory path into the popup dialog and press ENTER.
2. Press F1 to open the File menu and then select OPEN.
3. Enter the file name assigned to your Access program in the dialog box that appears and press ENTER.
4. The defined file will then appear in the Access window. Then press F2 and select SEND. The file loaded into the Access window is then sent to the Central controller.

Access Master Mode

When an Access device is placed in "Master Mode", the Central Controller's PROGRAM port is moved to the Access device's RS-232 port.

Press the escape key, then type either **MC** or **MD**:

- <esc>**MC** - connects the device in Master Mode
- <esc>**MD** - disconnects the device

where <esc> means "press the Esc key".



Master Mode can be very useful in situations where physical access to the Central Controller's PROGRAM port is not practical (for example, in installations where the Central Controller is located a long distance from the bus device(s)).

Replacing the Lithium Batteries

There are two lithium batteries on the controller's circuit card with a life of approximately five years. They protect stored commands against power loss. The batteries are not used when DC power is supplied to the controller. You should write down the replacement date on a sticker or label by adding five years to the date of installation, and then attach it to the rear panel for future reference.



Static electricity can damage electronic circuitry. Before removing the touch panel circuit card from the enclosure, discharge any accumulated static electricity from your body and flat-blade tool by touching a grounded metal object.

Contact your dealer before you replace the lithium batteries and verify they have a current copy of the software program stored in the controller. This will avoid any inadvertent loss of data or a service outage. To remove the controller's top panel, you will need a Phillips screwdriver.

You need non-conducting pliers to remove the lithium batteries from the controller.

1. Discharge the static electricity from your body by touching a grounded object.
2. Disconnect all power and data cables from the controller.
3. Hold the controller in place, and remove the mounting hardware from the equipment rack. Then, carefully remove the controller from the rack and place it on a flat surface.
4. Remove the six Phillips-head screws from the top panel on the controller. Then, remove the screws from the left and right side of the Axcent³ and Axcent³ Pro controller as shown in FIG. 11.

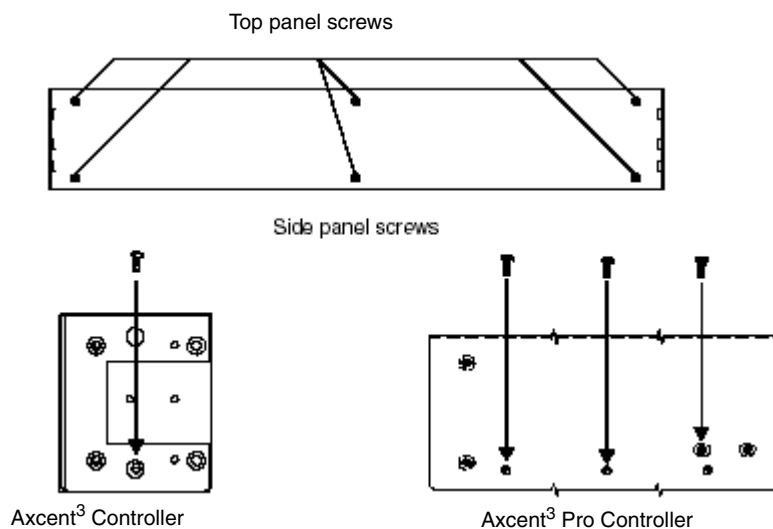

FIG. 11 Top and side panel screw locations

5. Remove the top panel and locate the batteries on the circuit card.

6. Carefully push the lithium battery, located in position B2, out of its socket, and remove with non-conduction pliers. With the rear of the unit facing you, insert the new battery with the positive (+) polarity side facing left.



Do not use any type of conductive tools to remove the battery. Doing so will damage the battery.

7. Plug the AXlink and power connectors back into the AXLINK/PWR connectors on the controller. Then, remove the connectors again. Be sure to write down the next replacement date on a sticker or label by adding five years to the replacement date, and then attach it to the back panel of the controller.
8. Repeat step 6 and 7 for the battery in position B1.
9. Place the top panel on the controller and align the screw holes. Insert the six Phillips-head screws and tighten. Then, insert screws in the left and right side of the controller and tighten.
10. Place the controller in the equipment rack, and align the mounting holes. Then, install the mounting hardware and tighten.
11. Connect all power and data cables back into the controller.

Updating Firmware

This section describes how to update the firmware in the controllers using the SOFTROM software program. Your PC must be connected to the PROGRAM DB-9 connector on the controller using a serial RS-232C-compatible cable. Refer to the *Wiring the Axcent3* section on page 5 for detailed wiring information.

To update:

1. Place the AMX SOFTROM diskette into drive A or B of your PC.
2. At the MS-DOS prompt C:>, type A:\ and press the ENTER key.
3. When the A:\> prompt appears on the screen, type SOFTROM and press the ENTER key.

Configuration

To configure the communication setting for the SOFTROM program:

1. Press F1 and the Configure screen appears. Make sure the BAUD RATE selections match the setting on the Access System Master controller.
2. Using the up/down arrow keys, select the communications port you are using to interface with the controller and press ENTER.
3. Using the right arrow key, move to the BAUD RATE column. Then use the up/down arrow keys to select the interface communications speed. Press ENTER.
4. Press F10 to save the communication settings and to exit the CONFIGURE screen. F2 can be pressed to select all ONLINE PANEL devices and F3 can be pressed to clear all devices.

Downloading Firmware

To download the firmware:

1. Press F5 to acquire the list of online programmable devices.
2. Using the up/down arrow keys, select your firmware versions listed in the Firm-ware column of the screen and press ENTER.
3. Using the Tab key, switch to the ONLINE MASTERS list.
4. Using the up/down arrow keys, select the devices to be programmed. Press ENTER for each device as it is selected.
5. Press F4 to program the selected devices; a loading message appears on the screen.
6. Press F5 to refresh the screen. Verify that the selected controllers have the correct firmware version. If any devices still indicated the old version, repeat steps 3-5 until all controllers appear with the correct firmware version.
7. Press F10 to exit the SOFTROM program.

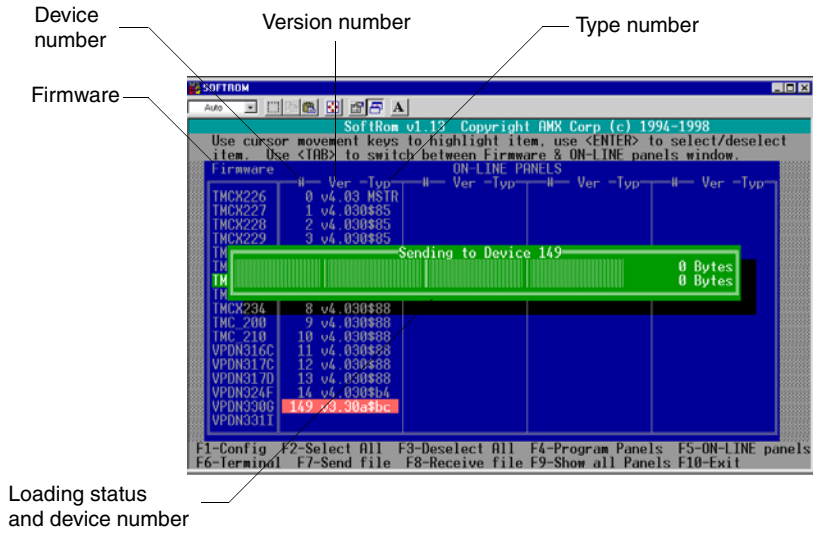

FIG. 12 Loading message

Firmware can be downloaded to multiple device numbers automatically. If multiple devices are selected, the bottom half of the loading bar will indicate the percentage complete for the selected devices.



AMX reserves the right to alter specifications without notice at any time.

ARGENTINA • AUSTRALIA • BELGIUM • BRAZIL • CANADA • CHINA • ENGLAND • FRANCE • GERMANY • GREECE • HONG KONG • INDIA • INDONESIA • ITALY • JAPAN
LEBANON • MALAYSIA • MEXICO • NETHERLANDS • NEW ZEALAND • PHILIPPINES • PORTUGAL • RUSSIA • SINGAPORE • SPAIN • SWITZERLAND • THAILAND • TURKEY • USA
ATLANTA • BOSTON • CHICAGO • CLEVELAND • DALLAS • DENVER • INDIANAPOLIS • LOS ANGELES • MINNEAPOLIS • PHILADELPHIA • PHOENIX • PORTLAND • SPOKANE • TAMPA
3000 RESEARCH DRIVE, RICHARDSON, TX 75082 USA • 800.222.0913 • 469.624.8000 • 469-624-7153 fax • 800.932.6993 technical support • www.amx.com

030-004-1590 9/05 ©2005 AMX Corporation. All rights reserved. AMX, the AMX logo, the building icon, the home icon, and the light bulb icon are all trademarks of AMX Corporation. AMX reserves the right to alter specifications without notice at any time. *In Canada doing business as Panja Inc.

Last Revision: 09/12/05