

The NI-900 (FG2105-90) is designed to control and automate a variety of devices in single rooms or multiple small rooms and is capable of supporting devices with a variety of communication formats. It is configured to control a limited number of lights, thermostats, video displays and other equipment.

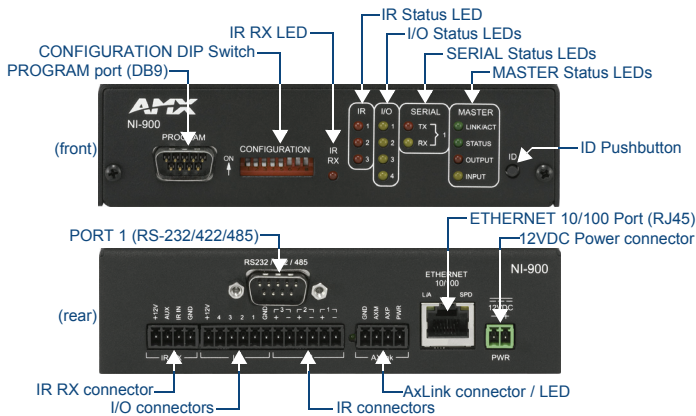

FIG. 1 NI-900

### ATTENTION!

Verify you are using the latest version of NetLinX Studio (available for download from [www.amx.com](http://www.amx.com)).

NI-900 Specifications	
Dimensions (HWD):	<ul style="list-style-type: none"> <li>1 9/16" x 5 9/16" x 5 1/8" (4.01 cm x 14.10 cm x 13 cm)</li> <li>RU: 1</li> </ul>
Power Requirement:	<ul style="list-style-type: none"> <li>300 mA @ 12 VDC</li> <li>Power requirements are usage dependant</li> </ul>
Memory:	<ul style="list-style-type: none"> <li>64 MB SDRAM (not upgradeable)</li> <li>32 MB Flash chip (not upgradeable)</li> <li>512 Kb of Non-volatile SRAM</li> </ul>
Microprocessor:	304 MIPS
Weight:	1.30 lbs (0.59 kg)
Enclosure:	Metal with black matte finish
Certifications:	FCC Part 15 Class B, CE, and IEC 60950
Front Panel Components	
PROGRAM Port:	RS-232 DB9 connector (male) can be connected to a DB9 port on a PC. This port can be used with both Serial and NetLinX commands.
CONFIGURATION DIP Switch:	8-position DIP Switch sets the communication parameters for the Program port.
IR RX LED (red):	Lights when IR data is being received via the rear IR RX port.
IR LEDs (red):	Light during the transmission of IR or Serial data via the 3 rear IR ports.
I/O LEDs (yellow):	Light when the rear I/O channels 1 - 4 are active. LED indicator for each I/O port reflects the state of that particular port.
SERIAL LEDs (red and yellow):	Light when the rear DB9 Port transmits or receives RS-232/422/485 data. <b>Note:</b> These LEDs do not reflect changes in either the RTS or CTS when hardware handshaking is used.
MASTER LEDs	<ul style="list-style-type: none"> <li>LINK/ACT (green): Lights when the Ethernet cable is connected and an active link is established. This LED also blinks when receiving Ethernet data packets.</li> <li>Status (green): Lights when the Controller is programmed and communicating properly.</li> <li>Output (red): Lights when the Controller transmits data, sets channels On and Off, sends data strings, etc.</li> <li>Input (yellow): Lights when the Controller receives data from button pushes, strings, commands, channel levels, etc.</li> </ul>
ID Pushbutton:	Sets the NetLinX ID (Device only) assignment for the device.
Rear Panel Components	
RS-232/422/485 (Port 1):	RS-232/422/485 control port uses a DB9 (male) connector with XON/XOFF (transmit On/transmit Off), CTS/RTS (clear to send/ready to send), and 300 - 115,200 baud.
IR RX (Port 6):	4-pin 3.5 mm mini-Phoenix port is used to connect up to 8 IRX-SM+ swivel mount or IRX-DM+ Decora mount IR receivers. <b>Note:</b> The IR RX port functions using AMX IR codes (38 KHz and 455 KHz) and works ONLY with AMX IR Receivers such as the IRX-DM+ and IRX-SM+.
I/O (Port 5):	4-channel digital I/O port for contact closure with each input being capable of voltage sensing. Input format is software selectable with interactive power sensing for IR ports. <b>Note:</b> The I/Os are not dry closure; they are electronic switches that float at 5V when Off. Therefore, they should not be expected to work in situations that require true dry contact (or dry closure). The I/Os do work with AMX PC1, PC2, UPC20 and UPC20+.
IR (Ports 2-4)	IR/Serial control ports support high-frequency carriers of up to 1.142 MHz with each output being capable of three electrical formats: IR, Serial, Data. 2 IR/Serial data signals can be generated simultaneously. <b>Note:</b> IR ports support data mode (at limited baud rates and wiring distances).

NI-900 Specifications (Cont.)	
Rear Panel Components	
AxLink Port/LED:	4-pin 3.5 mm mini-Phoenix (male) connector provides data and power to external control devices. Green AxLink LED indicates the status of the port.
ETHERNET 10/100 Port:	RJ-45 port for 10/100 Mbps communication. LEDs show communication activity, connection status, speeds, and mode information: <ul style="list-style-type: none"> <li>SPD (speed) - Yellow LED lights On when the connection speed is 100 Mbps and turns Off when the speed is 10 Mbps.</li> <li>L/A (link/activity) - Green LED lights On when the Ethernet cables are connected and terminated correctly, and blinks when receiving Ethernet data packets.</li> </ul>
12VDC PWR:	Power Port: 2-pin 3.5 mm mini-Phoenix (male) connector.
Operating Environment:	<ul style="list-style-type: none"> <li>Operating Temperature: 0° C (32° F) to 50° C (122° F)</li> <li>Operating Humidity: 20% - 85% RH</li> <li>Heat Dissipation (Typical): 12.3 BTU/hr</li> </ul>
Included Accessories:	<ul style="list-style-type: none"> <li>2-pin 3.5 mm mini-Phoenix female PWR connector (41-5025)</li> <li>6-pin 3.5 mm mini-Phoenix female I/O connector (41-5063)</li> <li>Three CC-NIRC IR Emitters</li> <li>Two 4-pin 3.5 mm mini-Phoenix female connectors (41-5047)</li> </ul>
Other AMX Equipment:	<ul style="list-style-type: none"> <li>AC-RK Accessory Rack Kit (FG515)</li> <li>CC-NIRC IR cables (FG10-000-11)</li> <li>CC-NSER IR/Serial cable (FG10-007-10)</li> <li>IRX-DM+ IR Sensor (FG458-10 and FG458-11)</li> <li>IRX-SM+ IR Sensor (FG455-01)</li> <li>PMB Pole Mount Bracket (FG531)</li> <li>STS, Serial To Screw Terminal (FG959)</li> <li>Surface Mount Bracket Accessory (FG525)</li> </ul>

## Port Assignment and Functionality

NI-900 Port Assignments	
Port	ICSP Port #
Serial Port #1	1
IR/Serial Port #1	2
IR/Serial Port #2	3
IR/Serial Port #3	4
I/O Port	5
IR RX Port	6

## Ethernet Ports Used By the NI Controller

Ethernet Port Usage		
Port type	Description	Standard Port #
FTP	The on-board Master has a built-in FTP server.	21/20 (TCP)
SSH	The SSH port functions using the same interface as Telnet but over a secure shell where it uses SSL as a mechanism to configure and diagnose a NetLinX system. <b>Note:</b> SSH version 2 (only) is supported.	22 (TCP)
Telnet	The NetLinX Telnet server provides a mechanism to configure and diagnose a NetLinX system.	23 (TCP)
HTTP	The Master has a built-in web server that complies with the HTTP 1.0 specification and supports all of the required features of HTTP v1.1. This port is used for unsecure HTTP Internet communication between the web browser's UI and the target Master.	80 (TCP)
HTTPS/SSL	This port is used by a web browser to securely communicate between the web server UI and the target Master.	443 (TCP)
ICSP	Peer-to-peer protocol used for both Master-to-Master and Master-to-device communications.	1319 (UDP/TCP)
integration! Solutions	This feature on the Master uses, by default, port 10500 for the XML based communication protocol. This port is connected to by the client web browser's JVM when integration! Solutions control pages are retrieved from the on-board Master's web server.	10500 (TCP)

**Note:** While the NI-900 is capable of receiving 8 and 9 bit characters, it cannot receive 7 bit, 1 stop bit data from a serial device (ex: 9600,N,7,1).

## RACK MOUNT SAFETY INSTRUCTIONS

- If installed in a closed or multi-unit rack assembly, the operating ambient temperature of the rack environment may be greater than room ambient. Therefore, consideration should be given to installing the equipment in an environment compatible with the maximum ambient temperature 50°C.
- Installation of the equipment in a rack should be such that the amount of air flow required for safe operation of the equipment is not compromised.
- Mounting of the equipment in the rack should be such that a hazardous condition is not achieved due to uneven mechanical loading.
- Consideration should be given to the connection of the equipment to the supply circuit and the effect that overloading of the circuits might have on over current protection and supply wiring.
- Reliable earthing of rack-mounted equipment should be maintained. Particular attention should be given to supply connections other than direct connections to the branch circuit (e.g. use of power strips).

## Installing Into an Equipment Rack

Use the optional AC-RK Accessory Rack Kit (FG515) to mount the Controller into a standard 19" equipment rack.

1. Discharge the static electricity from your body by touching a grounded object.
2. Align the front of the NI-900 through any of the three rectangular openings on the AC-RK.
3. Use the included mounting screws to secure the unit's faceplate to the AC-RK.
4. Thread the cables through the opening in the equipment rack. Allow for enough slack in the cables to accommodate for movement during the installation process.
5. Reconnect all cables to their appropriate source/terminal locations. Verify that the terminal end of the power cable is not connected to the a power supply before plugging in the 2-pin power connector.
6. Align the ends of the AC-RK with the screw openings along the sides of the equipment rack.
7. Secure the AC-RK to the rack by using the four #10-32 screws (80-0186) and four #10 washers (80-0342) supplied in the kit.
8. Apply power to the unit to complete the installation process.

## Connections and Wiring

### Wiring a Power Connection

Use a 12 VDC-compliant power supply to provide power to the NI-900 through the rear 2-pin 3.5 mm mini-Phoenix connector (FIG. 1). Use the previous power requirements information to determine the power draw.

The incoming PWR and GND cable from the power supply must be connected to their corresponding locations within the PWR connector. Refer to the *NetLinx Integrated Controllers* Instruction Manual for more detailed wiring connection information.

### RS-232/422/485 Connector Information

FIG. 2 shows the pinout and wiring specification information for the rear RS-232/RS-422/RS-485 (DB9) Device Port. This port support most standard RS-232 communication protocols for data transmission (the NI-900 uses only Port 1).

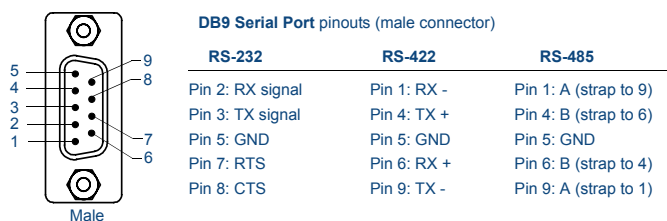

FIG. 2 RS-232/422/485 DB9 (male) connector pinouts

**WARNING:** When wiring the 422/485 connections, do NOT use pre-made 9-wire cable or connect the wire in the cable to any connection that will not be used by the DB9 serial port. Only use wiring that connects the needed pins.

### Ethernet 10/100 Base-T Connector

A standard CAT5 Ethernet cable provides 10/100 network connectivity between the Integrated Controller and the network (FIG. 3).

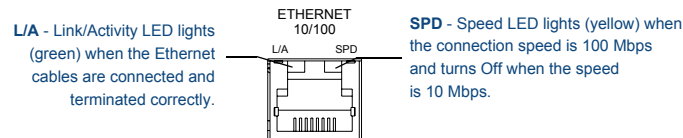

FIG. 3 Layout of Ethernet LEDs

**Note:** On *NetLinx Masters* (such as those aboard the NI-900), from within the *Telnet* or *Terminal* applications; you can send the `SET ETHERNET MODE` command to assign the speed of your Ethernet connection.

Sample NI-900 command:

```
SET ETHERNET MODE AUTO
```

The NI-900 only allows you to set the Ethernet mode to AUTO negotiate the Ethernet connection speed. Using any of the other connection modes (10 Half/Full or 100 Half/Full) results in an error message.

### Program Port Baud Rate Settings

The Configuration DIP switch is located on the front panel. Use this DIP switch to set the baud rate for the Program Port, according to the settings shown in the following table. Make sure the baud rate you set matches the baud rate on your PC's NetLinx COM Settings before programming the unit.

**By default, the baud rate is set to 38,400 (bps).**

**Note:** DIP switch 1 activates/deactivates the Program Run Disable Mode. DIP Switches 2,3, and 4 must remain OFF at all times.

Baud Rate Settings				
Baud Rate	Position 5	Position 6	Position 7	Position 8
9600 bps	OFF	ON	OFF	ON
38,400 bps (default)	OFF	ON	ON	ON
57,600 bps	ON	OFF	OFF	OFF
115,200 bps	ON	ON	ON	ON

## Setting the Configuration (Program Port) DIP Switch

1. Disconnect the power supply from the rear 2-pin PWR (green) connector.
2. Set DIP switch positions according to the information listed in the previous Baud Rate Settings table.
3. Reapply power to the unit.

## Preparing the NI-900 for Serial Communication

1. Launch *NetLinx Studio 2.x* (default location is **Start > Programs > AMX Control Disc > NetLinx Studio 2 > NetLinx Studio 2**).
2. Select **Settings > Master Communication Settings**, from the Main menu, to open the *Master Communication Settings* dialog box.
3. Click the **Communications Settings** button to open the *Communications Settings* dialog.
4. Click the **NetLinx Master** radio button (from the Platform Selection section) to indicate you are working with a NetLinx Master.
5. Click the **Serial** radio button (from the Transport Connection Option section) to indicate you are connecting to the Master via a COM port.
6. Click the **Edit Settings** button (on the *Communications Settings* dialog) to open the *Serial Settings* dialog and set the COM port parameters (used to communicate to the NetLinx Master).
7. Click the **OK** button three times to return to the main application.
8. Right-click the entry in the **Online Tree** tab and select **Refresh System**.
9. Assign a System Value by using **Diagnostics > Device Addressing** from the Main menu.
10. Enable the **Change System selection** by clicking on it and then enter the current and new System values.
11. Click the **Change Device/System Number** button and when finished click **Done**.
12. Select **Tools > Reboot the Master Controller** to access the *Reboot the Master* dialog, then click **Reboot** to restart the Master and incorporate any changes.
13. Once the dialog replies with "Reboot of system complete", click **Done** and then click the **OnLine Tree** tab in the Workspace window to view the devices on the System. *The default System value is one.*
14. Right-click on the *Empty Device Tree/System* entry and select **Refresh System** to re-populate the list.

## Configuring the NI-900 for Ethernet Communication

Before continuing, complete the COM port steps above.

1. Connect an Ethernet cable to the unit's rear Ethernet connector.
2. Select **Diagnostics > Network Address** from the Main menu and enter the System, Device (0 for a Master), and Host Name information.
3. To configure the Address:
  - Use a DHCP Address by selecting the **Use DHCP** radio button, then click the **GET IP** button (to obtain a DHCP Address from the DHCP Server), click the **SET IP Information** button (to retain the new address), and then finish the process by clicking the **Reboot Master > OK** buttons.
  - Use a Static IP Address by selecting the **Specify IP Address** radio button, enter the IP parameters into the available fields, then click the **SET IP Information** button (to retain the pre-reserved IP Address to the Master), and then click the **Reboot Master > OK** buttons to finish the process.
4. Repeat steps 1 - 5 from the previous section but rather than selecting the **Serial** option, choose **TCP/IP** and edit the settings to match the IP Address you are using (whether Static or IP).
5. Click on the **Authentication Required** radio box (if the Master is secured) and press the **User Name and Password** button to enter a valid username and password being used by the secured Master.
6. Click the **OK** button three times to return to the main application.

## Additional Documentation

Additional Documentation for the NI-900 is available at [www.amx.com](http://www.amx.com):

- Refer to the *NI-700/900 Hardware Reference Guide* for additional details on Installation, Upgrading, and Wiring the NI-900.
- Refer to the *NI Series NetLinx Integrated Controllers WebConsole & Programming Guide* for detailed configuration instructions.

