

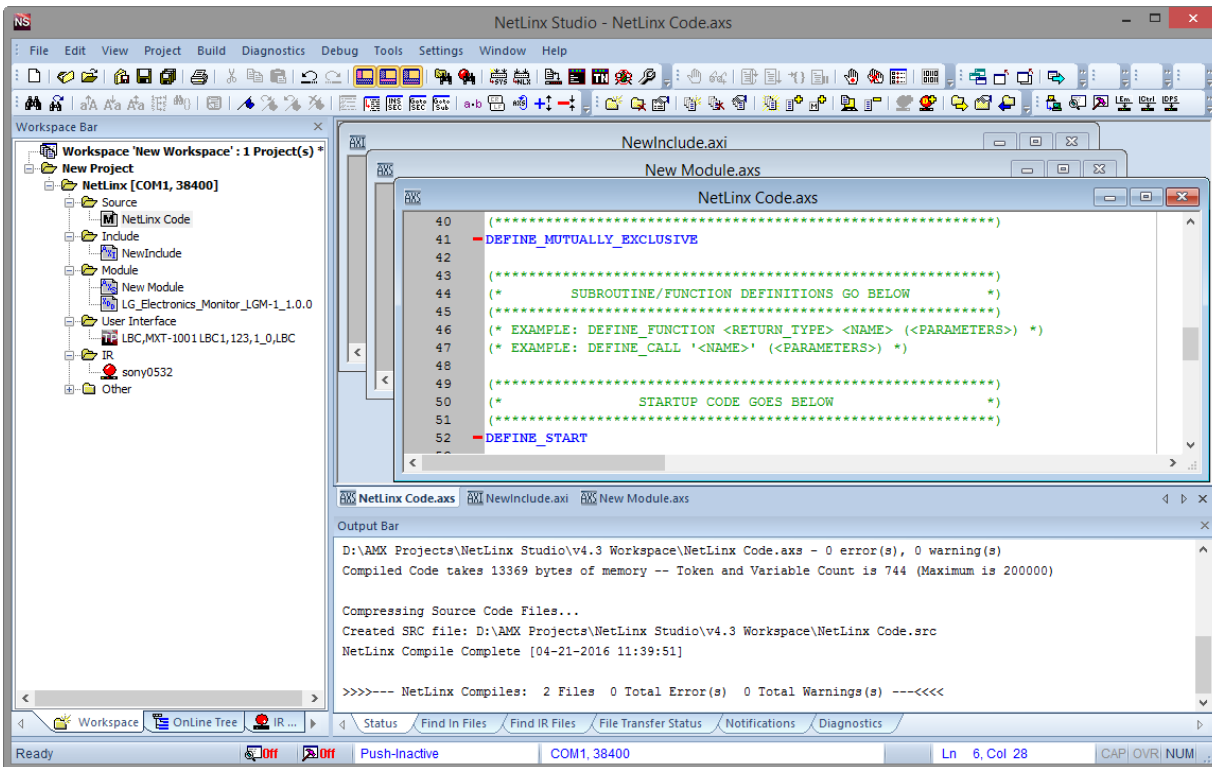

LANGUAGE REFERENCE GUIDE

NETLINX PROGRAMMING LANGUAGE





COPYRIGHT NOTICE

AMX© 2016, all rights reserved. No part of this publication may be reproduced, stored in a retrieval system, or transmitted, in any form or by any means, electronic, mechanical, photocopying, recording, or otherwise, without the prior written permission of AMX. Copyright protection claimed extends to AMX hardware and software and includes all forms and matters copyrightable material and information now allowed by statutory or judicial law or herein after granted, including without limitation, material generated from the software programs which are displayed on the screen such as icons, screen display looks, etc. Reproduction or disassembly of embodied computer programs or algorithms is expressly prohibited.

LIABILITY NOTICE

No patent liability is assumed with respect to the use of information contained herein. While every precaution has been taken in the preparation of this publication, AMX assumes no responsibility for error or omissions. No liability is assumed for damages resulting from the use of the information contained herein. Further, this publication and features described herein are subject to change without notice.

AMX WARRANTY AND RETURN POLICY

The AMX Warranty and Return Policy and related documents can be viewed/downloaded at www.amx.com.

Table of Contents

NetLinx Programming Language	17
Overview	17
Conventions Used in This Document.....	17
NetLinx Programming Overview	17
Mainline	17
Understanding When DEFINE_PROGRAM Runs.....	18
Summary:	18
The Four Conditions That Cause the NetLinx Master To Run DEFINE_PROGRAM	18
Unhandled Events	18
Writing To a Variable:	19
The 1/sec Fail-Safe Timer	19
The Empty Event Queue.....	20
Statements and Expressions	20
Statements	20
Expressions	20
Assignments	20
Variables.....	20
Output channels.....	20
Comments.....	21
Identifiers.....	22
Overview	22
Devices.....	22
Device Numbers - Supported Ranges by Device Type	22
Master Device Number	22
Physical Devices	22
Dynamically Assigned Devices.....	23
Virtual Devices	23
Device Arrays	23
Device Array Examples.....	23
Device-Channels and Device-Channel Arrays.....	24
Device-Level Arrays	24
Subroutines.....	26
Overview	26
DEFINE_CALL Subroutines	26
SYSTEM_CALL Subroutines	26
Function Subroutines.....	26
Calling Parameters	27
Subroutine Keywords	28
CALL	28
DEFINE_CALL.....	28
SYSTEM_CALL.....	28

Compiler Directives	29
Overview	29
#DEFINE	29
#DISABLE_WARNING	29
#ELSE	29
#END_IF	29
#IF_DEFINED	29
#IF_NOT_DEFINED	29
#INCLUDE	29
#WARN	29
Array Keywords	30
Overview	30
Multi-Dimensional Arrays.....	31
Array Keywords	32
LENGTH_ARRAY.....	32
MAX_LENGTH_ARRAY.....	32
SET_LENGTH_ARRAY	32
Audit Keywords	33
AUDIT_NETLINX_	
GENERIC_EVENT	33
AUDIT_NETLINX_	
SESSION_EVENT.....	33
Authentication Keywords	34
VALIDATE_NETLINX_	
ACCOUNT	34
VALIDATE_NETLINX_	
ACCOUNT_WITH_	
PERMISSION	34
Buffer Keywords	35
CLEAR_BUFFER.....	35
CREATE_BUFFER	35
CREATE_MULTI_BUFFER	35
GET_BUFFER_CHAR.....	36
GET_BUFFER_STRING	36
GET_MULTI_BUFFER_STRING	36
Channel Keywords	37
OFF	37
ON.....	37
TOTAL_OFF.....	37
Clock Manager Keywords	38
CLKMGR_SET_DAYLIGHT	
SAVINGS_OFFSET.....	38
CLKMGR_DELETE_USER	
DEFINED_TIMESERVER.....	38
CLKMGR_GET_ACTIVE_	
TIMESERVER	38
CLKMGR_GET_DAYLIGHTSAVINGS_OFFSET	38
CLKMGR_GET_END_	
DAYLIGHTSAVINGS_RULE.....	38
CLKMGR_GET_RESYNC_	
PERIOD.....	38
CLKMGR_GET_START_	
DAYLIGHTSAVINGS_RULE.....	38
CLKMGR_GET_	
TIMESERVERS	38

CLKMGR_GET_TIMEZONE	38
CLKMGR_IS_	
DAYLIGHTSAVINGS_ON	38
CLKMGR_IS_NETWORK_	
SOURCED.....	38
CLKMGR_SET_ACTIVE_	
TIMESERVER	38
CLKMGR_SET_CLK_	
SOURCE.....	38
CLKMGR_SET_	
DAYLIGHTSAVINGS_MODE.....	39
CLKMGR_SET_	
DAYLIGHTSAVINGS_	
OFFSET	39
CLKMGR_SET_END_	
DAYLIGHTSAVINGS_RULE.....	39
CLKMGR_SET_RESYNC_	
PERIOD.....	39
CLKMGR_SET_START_	
DAYLIGHTSAVINGS_RULE.....	39
CLKMGR_SET_TIMEZONE	39
Combine & Uncombine Keywords.....	40
Overview	40
Combining and Un-Combining Devices	40
Combining Devices	40
Un-combining Devices	41
Combining and Un-Combining Levels.....	42
Combining Levels.....	42
Un-combining Levels	42
Combining and Un-Combining Channels.....	43
Combining Channels.....	43
Un-combining Channels	43
COMBINE & UNCOMBINE Keywords	46
COMBINE_CHANNELS.....	46
COMBINE_DEVICES	46
COMBINE_LEVELS.....	46
DEFINE_COMBINE	46
DEFINE_CONNECT_LEVEL	46
UNCOMBINE_CHANNELS	46
UNCOMBINE_DEVICES	47
UNCOMBINE_LEVELS.....	47
Compiler Keywords	48
__DATE__	48
__FILE__.....	48
__LDATE__.....	48
__LINE__	48
__NAME__	48
__TIME__.....	48
Conditional & Loop Keywords	49
Overview	49
Conditionals.....	49
IF...ELSE	49
SELECT...ACTIVE	49
SWITCH...CASE Statements	50

Loops	50
FOR Loops	50
WHILE Loops	51
LONG_WHILE statements	51
Conditional and Loop Keywords	51
BREAK	51
DEFAULT	51
ELSE	51
FOR	52
IF	52
IF...ELSE	52
INCLUDE	52
SELECT... ACTIVE	52
SWITCH...CASE	52
WHILE	53
MEDIUM_WHILE	53
LONG_WHILE	53
FALSE	53
TRUE	53
Data Event Keywords	54
AWAKE	54
COMMAND	54
HOLD	54
ONERROR	54
OFFLINE	54
ONLINE	54
REPEAT	54
STANDBY	54
Data Types and Conversion Keywords	55
Overview	55
Intrinsic Data Types	55
Intrinsic Data Type Keywords	55
CHAR	55
WIDECHAR	55
INTEGER	55
SINTEGER	55
LONG	55
SLONG	55
Structured Data Types	56
DEV	56
DEVCHAN	56
DEVLEV	56
Combining and Uncombining Device/Channel Sets	56
FLOAT	56
DOUBLE	56
Type Conversion	57
Type Conversion Rules	57
Conversion Keywords	57
ATOI	57
ATOF	57
ATOL	58
CH_TO_WC	58
FTOA	58
HEXTOI	58
ITOA	58
FORMAT	59

ITOHEX.....	59
RAW_BE.....	59
RAW_LE.....	59
DEFINE Keywords.....	60
Overview	60
DEFINE_CALL	60
DEFINE_FUNCTION	60
DEFINE_CONSTANT.....	61
DEFINE Keywords	61
DEFINE_CALL.....	61
DEFINE_COMBINE	61
DEFINE_CONNECT_LEVEL.....	61
DEFINE_CONSTANT.....	61
DEFINE_DEVICE.....	61
DEFINE_EVENT	62
DEFINE_FUNCTION.....	62
DEFINE_LATCHING.....	62
DEFINE_MODULE	62
DEFINE_MUTUALLY_	
EXCLUSIVE.....	62
DEFINE_PROGRAM	62
DEFINE_START	62
DEFINE_TOGGLING.....	62
DEFINE_MUTUALLY_EXCLUSIVE and Variables.....	63
DEFINE_TYPE.....	63
DEFINE_VARIABLE.....	63
PROGRAM_NAME.....	63
RETURN.....	63
DEVICE Keywords.....	64
DEVICE_ID.....	64
DEVICE_ID_STRING.....	64
DEVICE_INFO.....	64
DEVICE_STANDBY	65
DEVICE_WAKE	65
DYNAMIC_APPLICATION_	
DEVICE.....	65
MASTER_SLOT	65
PUSH_DEVICE.....	65
RELEASE_DEVICE.....	65
PUSH_DEVCHAN	65
RELEASE_DEVCHAN.....	65
REBOOT	65
SEND_COMMAND.....	65
SYSTEM_NUMBER.....	65
Encode / Decode Keywords	66
Overview - Encoding and Decoding Binary and XML.....	66
Encode / Decode Keywords	70
STRING_TO_VARIABLE (VARIABLE DECODE).....	70
VARIABLE_TO_STRING (VARIABLE ENCODE).....	70
LENGTH_VARIABLE_TO_	
STRING (VARIABLE Encode).....	70
LENGTH_VARIABLE_TO_XML	71
VARIABLE_TO_XML.....	71
XML_TO_VARIABLE.....	72
Event Handler Keywords	74
Overview	74

Button Events.....	74
Channel Events	75
Data Events	76
Level Events	78
Custom Events	79
Event Parameters.....	79
Event Handler Keywords.....	81
BUTTON_EVENT.....	81
CHANNEL_EVENT.....	81
DATA_EVENT	82
LEVEL_EVENT.....	82
REBUILD_EVENT()	82
File Operation Keywords	84
FILE_CLOSE	84
FILE_COPY.....	84
FILE_CREATEDIR.....	84
FILE_DELETE.....	85
FILE_DIR.....	85
FILE_GETDIR	85
FILE_OPEN.....	85
FILE_READ.....	86
FILE_READ_LINE.....	86
FILE_REMOVEDIR	86
FILE_RENAME	86
FILE_SEEK	87
FILE_SETDIR.....	87
FILE_WRITE.....	87
FILE_WRITE_LINE.....	87
Get Keywords	88
GET_AVAILABLE_FLASH_	
DISK_SPACE.....	88
GET_DNS_LIST	88
GET_IP_ADDRESS.....	88
GET_LAST	88
GET_MAX_FLASH_DISK_	
SPACE	88
GET_PULSE_TIME.....	88
GET_SERIAL_NUMBER.....	88
GET_SYSTEM_NUMBER.....	88
GET_TIMER.....	88
GET_UNIQUE_ID.....	89
GET_URL_LIST.....	89
GET_URL_LIST Flags Member Bit Fields	90
IP Keywords	91
Overview - IP Communication	91
Client Programming.....	91
Initiating a conversation.....	91
Terminating a conversation	91
Sending data.....	92
Receiving data	92
Server Programming	93
Listening for client requests	93
Multiple client connections	93

Closing a local port	93
Connection-Oriented notifications.....	93
Receiving data	93
Sending data.....	94
Receiving Data with UDP	94
Multicast	94
Example IP Code.....	94
IP Keywords.....	96
ADD_URL_ENTRY	96
DELETE_URL_ENTRY	96
GET_DNS_LIST	96
GET_IP_ADDRESS.....	97
IP_BOUND_CLIENT_OPEN.....	97
IP_CLIENT_CLOSE	97
IP_CLIENT_OPEN.....	98
IP_MC_SERVER_OPEN	98
IP_SERVER_CLOSE.....	99
IP_SERVER_OPEN.....	99
IP_SET_OPTION.....	99
SET_IP_ADDRESS	100
SET_DNS_LIST.....	100
SSH_CLIENT_CLOSE	100
SSH_CLIENT_OPEN.....	101
TLS_CLIENT_CLOSE.....	101
TLS_CLIENT_OPEN	101
ADD_URL_ENTRY Flags Member Bit Fields	102
GET_IP_ADDRESS Flags Member Bit Fields	102
Level Keywords	103
~LEVSYNCON.....	103
~LEVSYNCOFF	103
COMBINE_LEVELS.....	103
CREATE_LEVEL	103
DEFINE_CONNECT_	
LEVEL	103
SEND_LEVEL	103
SET_VIRTUAL_LEVEL_	
COUNT.....	103
Listview Keywords.....	104
LISTVIEW_ON_ROW_SELECT_EVENT	104
DATA_FEED.....	104
DATA_FIELD	105
DATA_RECORD.....	105
WC_DATA_FEED.....	105
WC_DATA_FIELD	105
WC_DATA_RECORD.....	105
DATA_CREATE_FEED	106
DATA_DELETE_FEED	106
DATA_PUBLISH_FEED.....	106
DATA_GET_PUBLISHED_FEED.....	106
DATA_ADD_RECORD	107
DATA_GET_EVENT_RECORD.....	107
_WC_DATA_CREATE_FEED.....	108
_WC_DATA_ADD_RECORD.....	108
_WC_DATA_GET_EVENT_RECORD.....	108
Log Keywords.....	109
SET_LOG_LEVEL.....	109
GET_LOG_LEVEL	109
AMX_LOG.....	109

Math Functions	110
EXP_VALUE.....	110
LOG_VALUE.....	110
LOG10_VALUE.....	110
POWER_VALUE.....	110
SQRT_VALUE.....	110
Module Keywords	111
NetLinx Modules	111
Defining a Module	111
Using a Module in a Program	116
Module Keywords	117
DEFINE_MODULE	117
DUET_MEM_SIZE_GET	117
DUET_MEM_SIZE_SET	117
MODULE_NAME.....	117
Operator Keywords	118
Overview	118
Arithmetic Operators	118
Relational Operators	118
Logical Operators.....	118
Bitwise Operators	118
Assignment Operators	118
Operator Precedence.....	119
Operator Keywords	119
AND (&&).....	119
BAND (&).....	119
BNOT (~).....	119
BOR ().....	119
BXOR (^).....	119
LSHIFT.....	119
MOD (%).....	119
NOT (!).....	119
OR ()	119
RSHIFT	119
XOR (^).....	119
Port Keywords	120
DYNAMIC_POLLED_PORT.....	120
FIRST_LOCAL_PORT	120
STATIC_PORT_BINDING.....	120
Push and Release Keywords	121
DO_PUSH.....	121
DO_PUSH_TIMED.....	121
DO_RELEASE.....	121
MIN_TO	121
PUSH.....	121
PUSH_CHANNEL.....	121
PUSH_DEVCHAN.....	121
PUSH_DEVICE.....	121
RELEASE.....	121
RELEASE_CHANNEL.....	121
RELEASE_DEVCHAN.....	121
RELEASE_DEVICE.....	121
TO.....	122

SET Keywords	123
SET_DNS_LIST.....	123
SET_IP_ADDRESS.....	123
SET_LENGTH_ARRAY.....	123
SET_LENGTH_STRING.....	123
SET_OUTDOOR_	
TEMPERATURE.....	123
SET_PULSE_TIME.....	123
PULSE.....	123
SET_SYSTEM_NUMBER.....	123
SET_TIMER.....	123
SET_VIRTUAL_CHANNEL_	
COUNT.....	123
SET_VIRTUAL_LEVEL_COUNT.....	123
SET_VIRTUAL_PORT_COUNT.....	123
SMTP Keywords	124
Overview	124
SMTP_SERVER_CONFIG_SET.....	124
SMTP_SERVER_CONFIG_GET.....	124
SMTP_SEND.....	125
String Keywords	126
Overview	126
String Expressions.....	126
Wide Strings.....	126
STRING Keywords	127
CHARD.....	127
CHARDM.....	127
COMPARE_STRING.....	127
FIND_STRING.....	127
LEFT_STRING.....	127
LENGTH_STRING.....	128
LOWER_STRING.....	128
MAX_LENGTH_STRING.....	128
MID_STRING.....	128
REDIRECT_STRING.....	128
REMOVE_STRING.....	128
RIGHT_STRING.....	129
SEND_STRING.....	129
SET_LENGTH_STRING.....	129
STRING.....	129
STRING_TO_VARIABLE.....	129
UPPER_STRING.....	129
VARIABLE_TO_STRING.....	129
Structure Keywords	130
Overview	130
Example - Using Structures to Define a Database Table.....	130
Data Sets.....	131
STRUCTURE Keywords	132
DEFINE_TYPE.....	132
STRUCT.....	132
STRUCTURE.....	132
Time and Date Keywords	133
ASTRO_CLOCK.....	133
CLOCK.....	133
DATE.....	133

DATE_TO_DAY	133
DATE_TO_MONTH	133
DATE_TO_YEAR	133
DAY	133
DAY_OF_WEEK	133
LDATE	133
TIME	134
TIME_TO_HOUR	134
TIME_TO_MINUTE	134
TIME_TO_SECOND	134
Timeline Keywords	135
Overview	135
Creating a Timeline	135
TIMELINE Example	136
TIMELINE IDs	139
TIMELINE_ACTIVE	139
TIMELINE_CREATE	139
TIMELINE_EVENT	140
TIMELINE_GET	140
TIMELINE_KILL	140
TIMELINE_PAUSE	140
TIMELINE_RELOAD	140
TIMELINE_RESTART	140
TIMELINE_SET	141
UniCode Keywords	142
Overview	142
Working With UniCode in NetLinx Studio	142
Configuring NetLinx Studio	142
Enabling UTF-8 in NetLinx Studio	142
Enabling Unicode Compiling in NetLinx Studio	142
Including the Unicode Library	143
Defining a Unicode String Literal	143
Storing a Unicode String	143
Working with WIDECHAR Arrays and Unicode Strings	143
Character Case Mappings	144
Concatenating String	144
Converting Between WIDECHAR and CHAR	144
Using FORMAT	144
Reading and Writing to Files	144
Send Strings to a User Interface	145
Right-to-Left Unicode Strings	145
Compiler Errors	145
UniCode Keywords	146
_WC	146
WC_COMPARE_STRING	146
WC_CONCAT_STRING	146
WC_DECODE	146
WC_ENCODE	146
WC_FILE_CLOSE	147
WC_FILE_OPEN	147
WC_FILE_READ	147
WC_FILE_READ_LINE	148

WC_FILE_WRITE.....	148
WC_FILE_WRITE_LINE	148
WC_FIND_STRING	148
WC_GET_BUFFER_CHAR.....	148
WC_GET_BUFFER_STRING	149
WC_LEFT_STRING	149
WC_LENGTH_STRING	149
WC_LOWER_STRING.....	149
WC_MAX_LENGTH_STRING	149
WC_MID_STRING	149
WC_REMOVE_STRING.....	149
WC_RIGHT_STRING	150
WC_SET_LENGTH_STRING	150
WC_TO_CH	150
WC_TP_ENCODE	150
WC_UPPER_STRING	150

Variables Keywords..... 151

Overview	151
-----------------------	------------

Scope	151
--------------------	------------

Local Variables.....	151
----------------------	-----

Global Variables	152
------------------------	-----

Constancy	152
------------------------	------------

Persistence	152
--------------------------	------------

Non-Volatile Variables	152
------------------------------	-----

Volatile Variables	152
--------------------------	-----

Persistent Variables.....	152
---------------------------	-----

Constants.....	153
-----------------------	------------

Variables Keywords	153
---------------------------------	------------

ABS_VALUE	153
-----------------	-----

CONSTANT	153
----------------	-----

LOCAL_VAR.....	153
----------------	-----

MAX_VALUE.....	153
----------------	-----

MIN_VALUE	153
-----------------	-----

NON_VOLATILE.....	154
-------------------	-----

OFF	154
-----------	-----

ON.....	154
---------	-----

PERSISTENT.....	154
-----------------	-----

RANDOM_NUMBER	154
---------------------	-----

STACK_VAR	154
-----------------	-----

TOTAL_OFF.....	154
----------------	-----

TYPE_CAST.....	154
----------------	-----

VOLATILE.....	154
---------------	-----

Wait Keywords

Overview	155
-----------------------	------------

Types of Waits.....	155
---------------------	-----

Naming Waits.....	155
-------------------	-----

Nesting Waits.....	155
--------------------	-----

Using Waits - Limitations	155
---------------------------------	-----

WAIT keywords.....	155
---------------------------	------------

CANCEL_ALL_WAIT	155
-----------------------	-----

CANCEL_ALL_WAIT_UNTIL.....	155
----------------------------	-----

CANCEL_WAIT.....	155
------------------	-----

CANCEL_WAIT_UNTIL.....	156
------------------------	-----

PAUSE_ALL_WAIT	156
----------------------	-----

PAUSE_WAIT	156
RESTART_ALL_WAIT	156
RESTART_WAIT	156
WAIT	156
WAIT_UNTIL	156
TIMED_WAIT_UNTIL	156
Appendix A - Compiler Warning & Errors.....	157
Compiler Warnings	157
(w) Cannot assign unlike types.....	157
(w) DEFINE_CALL is not used	157
(w) Integer applies to arrays only	157
(w) Long_While within While.....	157
(w) Possibly too many nested levels.....	157
(w) Variable is not used	157
Compiler Errors.....	157
A "<symbol>" was expected.....	157
ACTIVE keyword expected.....	157
Allowed only in DEFINE_START	157
Attempted CALL to undefined subroutine.....	157
Comment never ends, EOF encountered.....	157
Conditional compile nesting too deep	157
Constant type not allowed	157
DEFINE_CALL must have a name.....	157
DEFINE_CALL name already used	158
Device values must be equal	158
Duplicate symbol.....	158
Evaluation stack overflow	158
Evaluation stack underflow	158
Identifier expected	158
Identifier is not an array type	158
Include file not found.....	158
Invalid include file name	158
Library file not found.....	158
Maximum string length exceeded.....	158
Must be char array reference.....	158
Must be integer reference.....	158
Out of memory	158
Parameter mismatch in CALL	158
PROGRAM_NAME must be on line 1	158
Push/Release not allowed within Push/Release.....	158
Push/Release not allowed within Wait.....	158
PUSH_CHANNEL not allowed within Wait.....	158
RELEASE_CHANNEL not allowed within Wait.....	158
PUSH_DEVICE not allowed within Wait	158
RELEASE_DEVICE not allowed within Wait	158
String constant expected.....	158
String constant never ends, EOF encountered.....	158
String literal expected.....	158
Subroutine may not call itself	158
Syntax error	158
SYSTEM_CALL name not same as PROGRAM_NAME in <file>.....	158
This variable type not allowed	158
Run-Time Errors.....	159
Bad assign 2dim.....	159
Bad assign Call	159
Bad element assign.....	159
Bad Off... Bad On... Bad To.....	159
Bad re-assign Call	159
Bad run token.....	159
Bad Set_Length.....	159
Bad While	159
TO statements that occur outside the data flow of PUSH events/statements may not work	159
Too few parameters in CALL	159
Too many include files	159

Too many parameters in CALL	159
Type mismatch in function CALL	159
Undefined identifier	159
Unmatched #END_IF	159
Unrecognized character in input file	159
Use SYSTEM_CALL [instance] 'name'	159
Variable assignment not allowed here	159
Wait not found	159
Appendix B - Master-To-Master (M2M)	160
Overview	160
Master-to-Master	160
Master Routing	160
Route Modes (Normal and Direct)	161
Design Considerations, Constraints, and Topologies	163
Design Considerations	163
Constraints	163
Chain Topology	163
Star Topology	164
Cluster Topology	165
Cascade Topology	166
Cluster Topology Modified	167
Configuring and Programming M2M Systems	168
Using NetLinx Studio with M2M Systems	168
Using Telnet with M2M Systems	169
Control/NetLinx Language Support	169
Design Consideration and Constraints	170
Inter-Master Variables	170
Using Virtual Devices as Moderators	170
Code Example: Tracking Online/Offline State In a Remote Master	170
Modifying the URL List From Within the NetLinx Code	170
M2M Processing Queues and Troubleshooting	170
General M2M Issues	170
Appendix C - Marshalling Protocol	171
Overview	171
Marshalled Stream Format	171
BYTE	171
WORD	171
DWORD	171
QWORD	171
BYTESTR	171
WORDSTR	171
DWORDSTR	171
QWORDSTR	171
LBYTESTR	171
Marshalling Protocol (Variables)	172
Marshalled Stream Format	172
BYTE	172
UWORD	172

WORD	172
ULONG	172
LONG	172
FLOAT	172
DOUBLE	172
STRUCT	172
ENDSTRUCT.....	172
ARRAY	172
SKIP	172
Encoding Notes.....	173
String Encoding	173
STRUCT	173
ARRAY	173
Array - String encoding (Strings).....	173
ARRAY - Binary Encoded	173
Binary Array Encoding	174
Binary Encoding Result	174
XML Encoding Result.....	176
Appendix D - NetLinx vs. Axxess	177
Overview	177
NetLinx vs. Axxess - Comparison by Structure	177
DEFINE_DEVICE	177
DEFINE_CONSTANT.....	177
DEFINE_VARIABLES	178
DEFINE_CALL (Subroutines)	178
DEFINE_START.....	178
DEFINE_EVENT	179
DEFINE_PROGRAM	179
Axxess/NetLinx Incompatibility	180
Combining Devices, Channels and Levels.....	180
Virtual devices, levels and device/channel sets.....	180
Combining and Uncombining devices.....	180
Combining and Uncombining levels.....	181
Combining and Uncombining channels	181
String Comparisons	181
Axxess code - string comparison	181
NetLinx code - string comparison	181
Modules	181

NetLinx Programming Language

Overview

NetLinx® is a superset of the Access language with extensions for additional data types, new event handlers, structure support, multi-dimensional arrays, and other features.

This document assumes that you are familiar with Access; the focus is on the new language elements and how they extend the functionality of the existing language. For background information on Access, refer to the *Access Programming Language* instruction manual.

Conventions Used in This Document

NetLinx contains a number of keywords that define various available operations to perform in a NetLinx command, such as the word `CALL` in the statement:

```
CALL 'Read Data' (Buffer)
```

Keywords are case insensitive. For example, the `PUSH` command is the same as `push`. Keywords are reserved, meaning that identifiers (device names, constants, or variables) must have unique names. These keywords are listed and defined in this document, separated by category.

- Square brackets indicate an optional element in a command.
- Angle brackets indicate substitution.

In the example below, the notation `<return type>` indicates that a valid data type (such as `CHAR`, `INTEGER`, or `FLOAT`) must be substituted for `<return type>`.

The square brackets surrounding it indicate that the return type is optional:

```
DEFINE_FUNCTION [<return type>] <name> [(Param1, Param2, ...)]
{
    (* body of subroutine *)
}
```

NetLinx Programming Overview

The NetLinx control system was designed to upgrade the processor bus and improve the power of the Access programming language. Originally named Access2, the NetLinx was designed to be a superset of the Access programming language. The relationship between the new language (NetLinx) and Access is very similar to the relationship between C++ and C.

Just as C++ brought a whole new level of power to C programming, NetLinx offers a variety of new tools and commands to dynamically increase the speed and power of present and future applications.

NOTE: Use the NetLinx Studio software program to create, compile, and transfer Access/NetLinx code.

Mainline

Mainline is the program section executed continuously by the NetLinx Central Controller as long as the Controller has power.

`DEFINE_PROGRAM` contains the code known as mainline.

A typical NetLinx program is composed of a number of different sections. Each section defines some aspect of a program such as device definitions, variable declarations, channel characteristics, or event processing. The sections that can comprise a NetLinx program are listed in the following table:

Program Sections	
<code>DEFINE_DEVICE</code>	<code>DEFINE_MUTUALLY_EXCLUSIVE</code>
<code>DEFINE_COMBINE</code>	<code>DEFINE_TOGGLING</code>
<code>DEFINE_CONSTANT</code>	<code>DEFINE_CALL</code>
<code>DEFINE_TYPE</code>	<code>DEFINE_FUNCTION</code>
<code>DEFINE_VARIABLE</code>	<code>DEFINE_START</code>
<code>DEFINE_CONNECT_LEVEL</code>	<code>DEFINE_EVENT</code>
<code>DEFINE_LATCHING</code>	<code>DEFINE_PROGRAM</code>

Not all of the sections listed above are required to create a complete program. In an Access system, only `DEFINE_PROGRAM` is required. In a NetLinx system, either `DEFINE_PROGRAM` or `DEFINE_EVENT` is required. Other sections are required only to support code in one of these two sections, although the compiler might require more.

Access communication updates occur only between passes through mainline (or after each iteration through `LONG_WHILE` loops). This places timing constraints on mainline processing in order for the system to operate properly. NetLinx avoids these constraints by processing network activity through a separate thread of execution. Bus activity is serviced concurrently with event processing and mainline execution. The event processing that previously could occur only through mainline code can now be handled through code in the `DEFINE_EVENT` section. This provides a more efficient mechanism for processing events; mainline does not have to be traversed to process a single I/O request. A handler can be defined for processing device-specific events, as well as providing feedback for the device initiating the event notification. If a handler is present, mainline will not be called to process the event; the handler is called instead. Once the handler completes its execution, the system is ready to process the next input message. When no more messages are pending, mainline runs.

In effect, mainline in NetLinx is an *idle time* process. With the addition of the `DEFINE_EVENT` section for processing events, the role of mainline in a NetLinx program becomes greatly diminished if not totally eliminated. Programs can still be written using the traditional technique of processing events and providing feedback through mainline code. However, programs written using the event table structure, provided in the NetLinx system, will run faster and be easier to maintain. FIG. 1 illustrates message and mainline processing as it appears in the NetLinx system. Note that bus servicing is taken care of by a separate process thread (*Connection Manager & Message Dispatcher*) and, therefore, is not a task that must follow mainline.

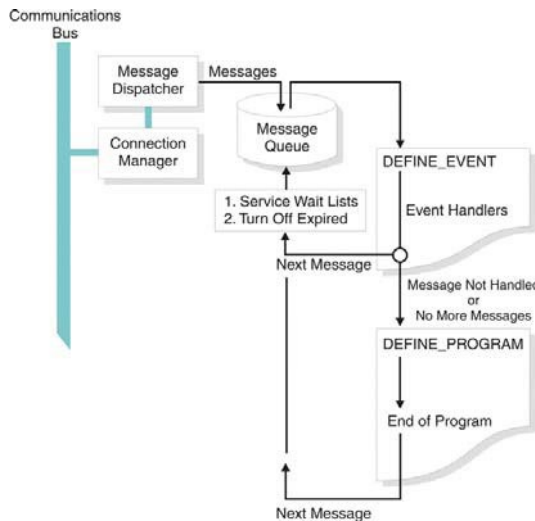

FIG. 1 Message and Mainline Processing in the NetLinx System

Understanding When `DEFINE_PROGRAM` Runs

This section describes the scenarios in which `DEFINE_PROGRAM` runs (or, why loops in mainline are bad). Understanding this process can explain programs with abnormally high CPU usage and how to fix them.

Summary:

- Use `STACK_VAR` whenever possible,
- Use a short `WAIT` in `DEFINE_PROGRAM` when it is not.

The Four Conditions That Cause the NetLinx Master To Run `DEFINE_PROGRAM`

1. An unhandled event occurs
2. A variable is written to* (this is the CPU usage culprit)
3. The 'run occasionally anyway' timer fires (~1/second)
4. The event queue has become empty

Unhandled Events

- `DEFINE_PROGRAM` runs when an unhandled event occurs, which ensures that channel- or level-based feedback is up to date.
- It also aids backwards compatibility by allowing `SYSTEM_CALLs` and mainline `PUSH` and `RELEASE` statements to run.

To understand unhandled events, consider the following code:

```

BUTTON_EVENT[dvTP, 123]
{
  PUSH:
  {
    PULSE[dvRelay, 1]
  }
}
  
```

When someone presses button 123, there are 3 unhandled events and 1 handled event. The button press has been handled by `PUSH`, but the `RELEASE`, channel `ON`, and eventual channel `OFF` are not handled. The result is that `DEFINE_PROGRAM` runs far more often than the button push in `DEFINE_EVENT`. Normally, this is not a large concern. (A user can only poke the system so fast). However, if you want to, you can prevent this by adding empty `BUTTON_EVENTS` and `CHANNEL_EVENTS`, like this:

```

BUTTON_EVENT[dvTP, 0]
{
  PUSH: {}
  RELEASE: {}
}

CHANNEL_EVENT[dvRelay, 0]
{
  ON: {}
  OFF: {}
}
  
```

Now, all channel-related events will be handled and `DEFINE_PROGRAM` will not run for these events.

Writing To a Variable:

The second condition (a variable being written to) is the culprit for abnormally high CPU usage. The intent behind this trigger for `DEFINE_PROGRAM` is to more accurately display feedback in a timely fashion. Since many people use `DEFINE_PROGRAM` to set button feedback with statements like:

```
[dvTP,201] = (nCurrentInput == 1)
```

...it makes sense to run `DEFINE_PROGRAM` if any change is detected in the states of any variable in the program. Normally, this is a very beneficial process. The problem comes with using loops to set feedback.

This code will cause high CPU usage:

```
DEFINE_VARIABLE

VOLATILE INTEGER INC

DEFINE_PROGRAM

FOR (INC=1; INC<=8; INC++)
{
  [dvTP,200+INC] = (nCurrentInput == INC)
}
```

It is not the loop itself that is the problem. It is the global variable `INC` being incremented that causes the issue. Since we've written to a variable, `DEFINE_PROGRAM` will want to run again. If there are no other events waiting in the queue, it will do so immediately. Of course, when it runs again, it will set itself up to run yet again....

The net result is that any time the processor would normally spend in an idle state is now consumed by repeatedly running `DEFINE_PROGRAM`. This does not interfere with processing events that come in, as they are given priority. The only speed penalty that is incurred is that the next incoming event can only be processed when the current pass of `DEFINE_PROGRAM` is finished. If you have an exceedingly long `DEFINE_PROGRAM`, it will slow event processing down.

The usual message conveyed with loops in mainline is "DON'T", but the code above can be fixed quite easily. All we need is a variable that won't be around when `DEFINE_PROGRAM` ends.

```
DEFINE_PROGRAM

{
  INTEGER INC
  FOR (INC=1; INC<=8; INC++)
  {
    [dvTP,200+INC] = (nCurrentInput == INC)
  }
}
```

There are three things to note here:

- We can arbitrarily 'compound' statements by placing them in braces
- Compounding allows us to define a local scope variable (they must be the first thing in a compound statement, before any executable code)
- The default local scope variable behavior is `STACK_VAR`, which is released once you leave that block of code

Since the variable is destroyed upon exiting the code, no variables are left in the dirty state. No dirty variables means no reason to run `DEFINE_PROGRAM`.

If we were to use a `LOCAL_VAR` instead, we would be back in a high CPU usage state as a `LOCAL_VAR` is non-volatile. It keeps its value between uses and is still around and 'written to' once `DEFINE_PROGRAM` is done. If you simply must use a `LOCAL_VAR` or a global-scope variable, there is still a way to salvage most of the CPU usage. If you employ a `WAIT`, you can control how often the feedback runs.

```
DEFINE_PROGRAM

WAIT 1
{
  LOCAL_VAR INTEGER INC
  FOR (INC=1; INC<=8; INC++)
  {
    [dvTP,200+INC] = (nCurrentInput == INC)
  }
}
```

Now, no matter how often `DEFINE_PROGRAM` is compelled to run, the feedback will only run 10 times per second. A particular `WAIT` in your NetLinx code can only be put in the `WAIT` list once at any given time. This makes it a great choice for periodic functionality.

The 1/sec Fail-Safe Timer

To make sure that any feedback statements in `DEFINE_PROGRAM` are enforced eventually, there is a timer that fires every second that compels `DEFINE_PROGRAM` to run. This is given priority over event processing.

The 1/second mode can be proven easily. Just write this as the only line in the program:

```
DEFINE_PROGRAM
SEND_STRING 0, 'DEFINE_PROGRAM JUST RAN'
```

Turn on NetLinx Internal Diagnostics Messages in NetLinx Studio and you will find that it occurs roughly once per second.

The 1/second fallback can cause one very large problem in one very specific situation. If you manage to write a `DEFINE_PROGRAM` section that takes more than one whole second to run (> 400,000,000 machine instructions on a current master) then you can actually stop processing any events.

The event queue servicing becomes starved. When the 'run anyway' timer expires, it has the highest priority of any of the triggers. If it fires before finishing the last 'run anyway' DEFINE_PROGRAM run, it will simply run again. If this happens every run of DEFINE_PROGRAM, no events will be processed and the master will appear to be locked up.

In practice, DEFINE_PROGRAM should never run this long. If you are in a situation where you must process this much information, you should consider making one iteration of a loop with each pass of DEFINE_PROGRAM. Instead of this:

```
DEFINE_PROGRAM
FOR(INC=1;INC<=4000000000;INC++)
{
    // DO SOMETHING AWFUL WITH THE UNSIGNED LONG INC
}

```

Do this:

```
DEFINE_PROGRAM

INC = INC MOD 4000000000 // FORCE THE RANGE OF 0-3999999999
INC++ // THEN ADD ONE

/// DO THE SAME HORRIBLE THING, BUT ONLY 1/PASS OF DEFINE_PROGRAM

```

Of course, if you have reached the point where DEFINE_PROGRAM takes longer than a second to run, you are past the point of needing another master on the job or re-evaluating your approach of the problem.

The Empty Event Queue

The final reason that DEFINE_PROGRAM will be run is when all the events that have come in have been processed. There are two reasons we should not care about this:

1. When it occurs, our system is, by definition, not busy
2. In busier systems, this occurs with decreasing frequency.

Statements and Expressions

Statements

A *statement* refers to a complete programming instructions such as:

```
Y = X (* Variable Assignment Statement *)
X = X + 1 (* Arithmetic Assignment Statement *)
IF (Y < 10) Y = Y + 1 (* IF Statement *)
[TP, 5] = [VCR, 1] (* Feedback Statement *)

```

Each of these statements compile, providing the referenced variables are defined.

Expressions

Expressions are sub-components of statements.

The following expressions are used in the above example:

```
X + 1 (* Arithmetic Expression *)
Y < 10 (* Logical Expression *)
Y + 1 (* Arithmetic Expression *)
[TP, 5] (* I/O Device Expression *)
[VCR, 1] (* I/O Device Expression *)

```

Expressions will not compile outside the context of a statement.

- It is strongly recommended that each statement appear on a separate line. The compiler cannot enforce this since full backward compatibility with the previous Axxess language must be maintained.
- It is also strongly recommended that semicolons be used to terminate each statement (as in the C language).

Assignments

Assignment statements include:

- Variables
- Output Channels

Variables

The simplest type of assignment statement is a variable, which assigns the value of an expression to a variable. The expression may be a constant, a variable / mathematical / logical expression, or a return from function. The data type associated with the expression should match the data type of the variable receiving the assignment. If not, the value of the expression is typecast to match the destination variable.

Example:

```
VariableName = <expression>
```

Output channels

This type of statement is typically used for feedback. It sends an output change to the specified channel on the given device.

Example:

```
[Device, Channel] = <expression>
```

The expression is evaluated as follows:

- If it is non-zero, the channel associated with the device is turned on.
- If it is zero, the channel is turned off.

Comments

Comments are designated with a parentheses-asterisk to begin the comment and asterisk-parentheses to end the comment; for example, (*COMMENT*). These comments can span lines and are not limited in length.

NetLinx supports a second type of comment with a double forward-slash (//). All text following the double forward-slash is treated as a comment. This type of comment closely follows the conventions of C++.

Comments are not part of the actual program code; they are not compiled. Comments can appear anywhere except within literal strings, either on the same line as a programming statement or on a separate line. Comments can span multiple lines with a single set of comment delimiters and can be nested. The compiler recognizes nested comments by pairing up sets of comment delimiters. For example:

```
(* The section to follow contains all variable declarations. *)
```

Single line comments can be specified using the double forward slash (//) notation.

When a pair of forward slash characters is encountered, all text on the same line following the slash pair, except the *) end comment sequence, is considered a comment and ignored by the compiler. For example:

```
(*INTEGER V011 // volume for room 1 *)
```

The "*)" in the line above terminates the open "(*" command even though it appears after a double slash comment command.

Identifiers

Overview

An Identifier is a combination of letters, numbers, or underscores that represents a device, constant, or variable. Identifier types include:

- Devices
- Device Arrays
- Channel Arrays
- Device-Channel Arrays
- Level Arrays
- Device-Level Arrays

Devices

A *Device* is any hardware component that can be connected to the NetLinx bus. Each device must be assigned a unique number to identify it on the bus.

- NetLinx allows device numbers in the range 0-32767.
- Device 0 refers to the Master; numbers above 32767 are reserved for internal use.

NetLinx requires a Device:Port:System (D:P:S) specification where Access expects only a device number. This D:P:S triplet can be expressed as a series of constants, variables separated by colons, or a DEV structure. For example:

```
STRUCTURE DEV
{
    INTEGER Number      // Device number
    INTEGER Port        // Port on device
    INTEGER System      // System device belongs to
}
```

A device specification in NetLinx can be expressed in one of two ways:

- **Device Number:** The compiler replaces the device number with an internally generated DEV structure. This DEV structure contains the specified device Number. If the system and port specifications are omitted (e.g. 128), **System 0** (indicating this system - the system executing the code), and **Port 1** (indicating the first port), is assumed.
- **Device:Port:System (D:P:S):** This notation is used to explicitly represent a device number, port, and system. For example, **128:1:0** represents the first port of the device number 128 on this system.

The syntax:

```
NUMBER:PORT:SYSTEM
```

Parameters:

Number 16-bit integer representing the Device number

- Physical devices range from 1 to 32,000
- Virtual devices range from 32,768 to 36,863

Port 16-bit integer representing the Port number, in the range 1 through the number of ports on the device (1 = this port)

System 16-bit integer representing the System number (0 = this system).

Device Numbers - Supported Ranges by Device Type

Each device requires a device number within the network, but many devices have range limitations on the device number that may be used. If an incorrect device number outside of that range is assigned to a particular device, the module may not function properly.

Master Device Number

The device number for the Master on a network must always be 0.

Physical Devices

Physical devices may be assigned a device number between 1 and 32000, with the exception of the examples in the table below:

Physical Device Numbers	
1-32000	Physical Devices
1-255	Access or AxLink devices
5001	Traditional device number for the NetLinx Integrated Device
5002	Traditional device number for the NetLinx Integrated Switcher
6001-6999	Traditional device numbers for ICSNet and ICSLan devices, including DXLink Tx and Rxs
10001-32000	Touch panels

Dynamically Assigned Devices

Device numbers dynamically assigned by the network are limited in range:

Dynamically Assigned Device Numbers	
32001-32767	Dynamically assigned device numbers

Virtual Devices

Virtual devices must be assigned within a range of 32768 to 42000, with specific ranges for virtual device subcategories:

Virtual Device Numbers	
32768-42000	Virtual Devices
32768-36864	User defined virtual devices
36865-37864	Dynamic Virtual Devices
37865-40999	NetLinx Module Virtual Devices
41001-42000	Duet Module Virtual Devices
45001-45999	Auto-setup DXLink Transmitters
46001-46999	Auto-setup DXLink Receivers

Device Arrays

In order to specify a group of devices for a command or event handler, NetLinx provides the capability to define an array of DEVs and treat it as a device array. A device array may be used anywhere a device specification is required. The result provides a range of targets for the command or instruction where it is used. Device arrays are declared in the `DEFINE_VARIABLE` section of the program in one of two ways:

```
DEV DSName[ ] = {Dev1, Dev2, ..., Devn}
DEV DSName[MaxLen] = {Dev1, Dev2, ..., Devn}
```

Each device name appearing on the right-hand side of the declaration should be defined as a device in the `DEFINE_DEVICE` section; however, it can also be defined in the `DEFINE_VARIABLE` or `DEFINE_CONSTANT` section.

The first statement above declares a device array whose maximum length is determined by the number of elements in the initialization array on the right-hand side. The second form uses *MaxLen* to specify the maximum length of the device array. In either case, the number of elements in the initialization array determines the effective length of the device array. That value can be determined at run-time by calling `LENGTH_ARRAY`. The maximum length available for a device array can be determined by calling `MAX_LENGTH_ARRAY`.

The following program fragment illustrates device array initialization:

```
DEFINE_DEVICE
panel3 = 130
DEFINE_CONSTANT
DEV panel1 = 128:1:0
integer panel2 = 129

DEFINE_VARIABLE
// dvs is an array of three devices:
// 128:1:0
// 129:1:0
// 130:1:0
DEV dvs[ ] = {panel1, panel2, panel3}
```

The individual elements of a device array can be referenced by their defined names (Dev1, Dev2, etc.) or by using array notation with the device array name. For example, the 3rd device in the device array, MyDeviceSet, would be referenced by `MyDeviceSet[3]`. The index of the last member of the array for which an event notification was received can be determined by calling `GET_LAST(MydeviceSet)`. This is useful for determining which device in an array is referenced in a particular notification message.

Device Array Examples

The command below sends 'CHARD10' to all devices in the array, DeviceSetA.

```
DEV DeviceSetA[ ] = {Device1, Device2, Device3}
SEND_COMMAND DeviceSetA, 'CHARD10'
```

The command below sends 'CHARD10' to the third device in the array, DeviceSetA,

```
SEND_COMMAND DeviceSetA[3], 'CHARD10'
```

and is equivalent to:

```
SEND_COMMAND Device3, 'CHARD10'
```

The intent of the feedback statement is to set channel 1 in every device in DeviceSetA to either on or off, depending on the value of the right-hand expression; it is unclear what the right-hand expression evaluates to. The compiler will issue a warning indicating the syntax is unclear and that `DeviceSetB[1]` is assumed. To avoid this warning, specify a particular device in the array. For example:

```
{DeviceSetA, 1} = [DeviceSetB[1], 2] (* Correct *)
```

Device-Channels and Device-Channel Arrays

As the name implies, a device-channel (DEVCHAN) is a combination of a device and a channel. It is represented internally as a DEVCHAN structure. This structure combines the fields of a DEV structure representing the device with a field representing the channel number:

```
STRUCTURE DEVCHAN
{
    DEV                //Device
    INTEGER            //Channel
}
```

The first component of a device-channel pair represents the Device Number, Port, and System. It can be specified as either a single device number, a constant DEV structure or as a D:P:S specification. Each device specified in a device-channel pair should be defined in the DEFINE_DEVICE section.

Channels are expressed as integer constants. A DEVCHAN is declared in either the DEFINE_VARIABLE or DEFINE_CONSTANT section. For example, "[128, 1]", "[CONSTANTDPS, 9]" and "[128:1:0, 5]" are all valid representations of device-channel pairs. A DEVCHAN enclosed within square brackets implies an evaluation, whereas a DEVCHAN enclosed within curly braces does not, as illustrated below:

```
DEFINE_VARIABLE
DEVCHAN dcl = {128:1:0, 1}
DEVCHAN dcset[ ] = { {128:1:0, 1}, {128:1:0, 2}, {128:1:0, 3} }

DEFINE_PROGRAM

IF ( [dcl] || [128:1:0, 2] )           // evaluation of 2 devchans
[dcl] = 1                               // feedback

dcl = {129:1:0, 2}                       // assigns a new value to dcl
[dcl] = {129:1:0, 2}                     // Syntax Error!
```

A DEVCHAN array is declared in the DEFINE_VARIABLE or DEFINE_CONSTANT section in one of two ways:

- Declare a DEVCHAN array whose maximum length is determined by the number of elements in the initialization array on the right-hand side, as shown below:

```
DEVCHAN[ ] DCSName = {{Dev1,Chan1}, {Dev2,Chan2}, ...}
```

- Use MAXLEN to specify the maximum length of the array, as shown below:

```
DEVCHAN[ ] DCSName[MAXLEN] = {{Dev1,Chan1}, {Dev2,Chan2}, ...}
```

In either case, the number of elements in the initialization array determines the effective length of the array. That value can be determined at run-time by calling LENGTH_ARRAY. The maximum length available for a DEVCHAN[] array can be determined by calling MAX_LENGTH_ARRAY.

The individual elements of a DEVCHAN array can be referenced by their defined names (Dev1, Chan1, Dev2, Chan2, etc.) or by using array notation with the device-channel array name. For example, the third element in the device-channel array, MyDCSet, would be referenced by MyDCSet[3]. Furthermore, since a DEVCHAN array is an array of DEVCHAN structures, DEVCHAN members can be referenced using the dot operator notation such as MyDCSet[3].Device or MyDCSet[1].Channel.

A DEVCHAN array can be used anywhere a [Device, Channel] specification is required with the result of providing a range of targets for the command or instruction where it is used. This implies an alternate form for the following commands:

```
Button[ (DEVCHAN) ]           PULSE[ (DEVCHAN) ]
DO_PUSH[ (DEVCHAN) ]         PUSH[ (DEVCHAN) ]
DO_RELEASE[ (DEVCHAN) ]     RELEASE[ (DEVCHAN) ]
OFF[ (DEVCHAN) ]             TO[ (DEVCHAN) ]
ON[ (DEVCHAN) ]
```

The index of the last member of the array for which an event notification was received can be determined by calling GET_LAST(MyDCSet). This is useful for determining which device and channel in an array is referenced to in a particular notification message.

Device-Level Arrays

A device-level array (DEVLEV array) is an array of device-level pairs. Each element is represented internally as a DEVLEV structure. This structure combines the fields of a DEV structure representing the device with a field representing the level number.

```
STRUCTURE DEVLEV
{
    DEV                // Device
    INTEGER            // Level
}
```

The first component of a device-level pair (Device) represents the device number, port, and system. It can be specified as either a single device number, a constant DEV structure or as a D:P:S specification. Each device specified in a device-level pair should be defined in the DEFINE_DEVICE section. The second component is the level number on the device. The level number is expressed as an integer constant.

A DEVLEV array is declared in the DEFINE_VARIABLE or DEFINE_CONSTANT section in one of two ways:

- Declare a DEVLEV array whose maximum length is determined by the number of elements in the initialization array on the right-hand side.

```
DEVLEV DLName[ ] = {{Dev1,Level1}, {Dev2,Level2}, ...}
```

- Use MAXLEN to specify the maximum length of the array.

```
DEVLEV DLName[MAXLEN] = {{Dev1,Level1}, {Dev2,Level2}, ...}
```

In either case, the number of elements in the initialization array determines the effective length of the array. That value can be determined at run-time by calling LENGTH_ARRAY. The maximum length available for a DEVLEV array can be determined by calling MAX_LENGTH_ARRAY.

The individual elements of a level array can be referenced by their defined names (Dev1, Level1, Dev2, Level2, etc.) or alternatively, by using array notation with the device-level array name. For example, the 3rd element in the device-level array, MyDLSet, would be referenced by MyDLSet[3]. Furthermore, since a DEVLEV array is an array of DEVLEV structures, DEVLEV members can be referenced using the dot operator notation such as MyDLSet[3].Device or MyDLSet[1].Level.

The index of the last member of the array for which an event notification was received can be determined by calling GET_LAST(MyDLSet). This is useful for determining which device and level in an array is referenced to in a particular notification message.

Subroutines

Overview

A *Subroutine* is a section of code that stands alone, and can be called from anywhere else in the program.

DEFINE_CALL Subroutines

The `DEFINE_CALL` is the standard method provided by NetLinx for defining subroutines.

```
DEFINE_CALL '<subroutine name>' [(Param1,Param2,...)]
{
    (* statements *)
}
```

where (Param1, Param2, ...) refers to a comma-separated list of <datatype><variable> pairs. For example, "INTEGER Size" would be one pair.

`DEFINE_CALL` names must not conflict with previously defined constants, variables, buffers, or wait names. Unlike identifiers, `DEFINE_CALL` names are case sensitive.

A subroutine may accept parameters. To do this, each parameter and its type must be listed within the set of parentheses to the right of the subroutine name, as shown below:

```
DEFINE_CALL 'Read Input' (CHAR Buffer)[ ]
{
}
}
```

To invoke a user-defined subroutine, use the `CALL` keyword plus the name of subroutine and any required calling parameters.

```
CALL 'Read Input' (Buf1)
```

In NetLinx, `DEFINE_CALL` supports the `RETURN` statement (as shown in the following example), although return values are not supported.

```
DEFINE_CALL 'Read Input' (CHAR Buffer)
{
    if (nChars = 0)
    {
        RETURN // exit subroutine
    }
    (* read input *)
}
```

SYSTEM_CALL Subroutines

A `SYSTEM_CALL` subroutine is a special type of `DEFINE_CALL` subroutine defined in a separate program file called a LIB file with a `PROGRAM_NAME` entry matching the subroutine name.

```
PROGRAM_NAME = 'COSX'

DEFINE_CALL 'COSX' (FLOAT X)
{
    (* body of subroutine *)
}
```

To invoke a system call, use the `SYSTEM_CALL` keyword followed by the name in single quotes and any calling parameters, as shown below:

```
SYSTEM_CALL 'COSX' (45)
```

System calls are resolved automatically at compile time, without requiring an `INCLUDE` instruction to include the system call source file. For special cases where multiple copies of a system call are needed, an instance number can be specified in the call. The compiler will compile a separate copy of the subroutine for each system call instance number. For example, the following commands force the compiler to include two separate copies of `COSX`:

```
SYSTEM_CALL[1] 'COSX' (45)
SYSTEM_CALL[2] 'COSX' (60)
```

This technique could be useful in cases where a system call contains a wait instruction that conflicts when multiple calls to the same subroutine were made during a single wait period.

Function Subroutines

A function is similar to a `DEFINE_CALL`, but is intended for use either standalone or in-line as an expression. Instead of requiring a string literal for its name, it requires a name that follows the rules for naming constants and variables. This eliminates the need for using the `CALL` keyword to invoke the subroutine. `DEFINE_FUNCTION` subroutines also differ from `DEFINE_CALL` by allowing values to be returned using the `RETURN` statement (see below).

NOTE: *The return type may only be one of the 8 intrinsic types. Strings, arrays, structures, classes and other user-defined types may not be returned.*

Syntax:

```
DEFINE_FUNCTION [<return type>] FnName[(Param1,Param2,...)]
{
    (* statements *)
}
```

NOTE: *You cannot declare and initialize variables in the same line. You must group the declarations first, followed by the initialization.*

Example:

```

DEFINE_FUNCTION INTEGER myFunction (INTEGER Var0)
{
    INTEGER nBytes
    STACK_VAR RESULT
    nBytes = 0
    RESULT = Var0 + nBytes
    RETURN RESULT
}

```

NOTE: When it is a NetLinx function, a syntax where there appears a ([]), the () are NOT OPTIONAL but the [] are optional.

The DEFINE_FUNCTION subroutine can be called as a single programming statement. For example, the following syntax:

```

ReadBuffer(Buffer, BufSize)
Can be used in an assignment statement such as:
Count = ReadBuffer(Buffer, BufSize)
or as part of an expression such as:
IF (ReadBuffer(Buffer, BufSize) > 0)
{
    (* statements *)
}

```

The rules pertaining to calling parameters are the same for DEFINE_FUNCTION as they are for DEFINE_CALL subroutines. The parameter list must appear in parentheses to the right of the function name. If the function has no calling parameters a set of parentheses must still be included. For example,

```
MyFunc() // calling a function with no parameters
```

The return type may be omitted, as an alternate way of defining a subroutine. In this case the function cannot be used as part of an expression or in an assignment statement.

DEFINE_FUNCTION also allows the use of the RETURN keyword that serves two purposes:

- To return prematurely from a function.
- To return a value from a function.

The format of the return statement is:

```
RETURN [<return value>]
```

If a return statement is encountered anywhere in the function, execution of the function is terminated immediately and the value (if any) specified as the <return value> is returned to the caller. A function that returns a value through the RETURN keyword must be declared with a return type. Conversely, a function that is declared without a return type cannot return a value. In the example below, GetBufferSize returns an unsigned 16-bit integer, BufSize. The return type is indicated before the DEFINE_FUNCTION keyword.

```

DEFINE_FUNCTION INTEGER GetBufferSize()
LOCAL_VAR INTEGER BufSize = 0;
{
    .
    .
    .
    RETURN BufSize;
}

```

To call this function and to retrieve the RETURN value, use the following syntax:

```
BufSize = GetBufferSize()
      where BufSize is declared to be of type INTEGER.
```

Even if a function returns a value, it is not necessary to assign the return value to a variable. Both forms of the following call are valid. In the second case, the return value is simply thrown away.

```

Count = ReadBuffer(Buffer, BufSize)
ReadBuffer(Buffer, BufSize) // return value is ignored

```

NOTE: The return type may only be one of the 8 intrinsic types (see Data Types). Strings, arrays, structures, classes and other user-defined types may not be returned.

Calling Parameters

Parameters may be passed to any NetLinx function or subroutine. *Calling parameters* are simply variables or constants that originate from the caller and are received by the function or subroutine being invoked. The NetLinx compiler passes all variables by *reference*. This means that the variable the subroutine operates on is the same variable the caller passed. Any change made to a variable passed as a calling parameter updates the value of the variable from the perspective of the caller. You can take advantage of this *pass by reference* feature to return an updated value through a calling parameter rather than as the return value.

Constants, on the other hand, are passed by *value*. When this happens, a copy of the parameter is delivered to the subroutine. Any change made to the variable representing the constant is lost once the function or subroutine finishes.

Function and subroutine declarations must include the type and name of each parameter expected. If the type is omitted, the default type is assumed; arrays are CHAR type and non-array parameters are INTEGER. To specify an array as a function or subroutine parameter, one set of brackets for each array dimension must follow the variable name, as shown below:

```

DEFINE_CALL 'Process Array' (CHAR Array[ ][ ])
{
    (* body of subroutine *)
}

```

The parameter Array is declared to be a 2-dimensional array, by including two sets of brackets after the name. For compatibility with existing programs, the array dimensions may be specified inside the brackets. These dimensions are not required and are ignored by the compiler. The NetLinx interpreter will do bounds checking on the array and generate a run-time error if the array bounds are exceeded.

When calling a subroutine that takes an array as one of its parameters, pass only the name of the array as the calling parameter, as shown below:

```
CHAR Buffer[10][20]
CALL 'Process Array' (Array)
```

If dimensions are specified in the call statement, the compiler will interpret that as specifying a subset of the array. For example, suppose Array were defined as a 3-dimensional array. The third table of that dimensional array could be passed to 'Process Array' as follows:

```
CHAR Buffer[5][5][10]
CALL 'Process Array' (Array [3])
```

Subroutine Keywords

NetLinx supports the following Subroutine keywords:

DEFINE Keywords	
CALL	<p>Use the CALL keyword and the name of the subroutine in single quotes to tell NetLinx to execute a subroutine. For example, to execute the subroutine Lights Off, type the following where you want the CALL to occur:</p> <pre>CALL 'Lights Off'</pre> <p>When NetLinx executes the CALL, program execution jumps to the first line inside the braces of the DEFINE_CALL. The subroutine is executed only once, and then NetLinx returns to the statement directly following the CALL statement.</p>
DEFINE_CALL	<p>This keyword defines the implementation of a NetLinx subroutine.</p> <pre>DEFINE_CALL '<name>' [(P1,P2,...)] { // body of subroutine }</pre> <p>The subroutine name cannot be a previously defined device name, constant, or variable, or a name assigned to a buffer or a wait statement. DEFINE_CALL names are case sensitive and may contain spaces.</p> <p>NOTE: <i>Subroutines must be defined before they can be used. For this reason, DEFINE_CALLS should appear before the DEFINE_START, DEFINE_EVENT, and DEFINE_PROGRAM sections.</i></p>
SYSTEM_CALL	<p>This keyword is similar to CALL except that the subroutine invoked using the SYSTEM_CALL keyword resides in a special file called a library file. When this keyword is used, the compiler generates a call to the subroutine in the library file and automatically includes the library file for compilation.</p>

Compiler Directives

Overview

Compiler Directives are special types of instructions for the compiler. They won't produce any runtime code. Instead, they allow you to instruct the compiler to conditionally compile parts of the code. See page 48 for a listing of Compiler Keywords.

NOTE: Refer to *Appendix A - Compiler Warning & Errors* section on page 157 for a listing of Compiler Messages.

Compiler Directives	
#DEFINE	<p>This directive defines a symbol to be used only by #IF_DEFINED and #IF_NOT_DEFINED directives.</p> <p>Syntax:</p> <pre>#DEFINE <symbol></pre> <p>The name of the symbol must be unique among all other identifiers in the program. The symbol can be defined anywhere in the program file but cannot be used in any statement that appears before it is defined.</p> <pre>// Specify the INCLUDE_TOGGLE_VIDEO_PROJECTOR_POWER_FUNCTION compiler // directive if there is a video projected connected to the controller #define INCLUDE_TOGGLE_VIDEO_PROJECTOR_POWER_FUNCTION #if_DEFINED INCLUDE_TOGGLE_VIDEO_PROJECTOR_POWER_FUNCTION DEFINE_FUNCTION toggleVideoProjectorPower() { // code to toggle video projector power goes here } #endif</pre> <p>Notice in the above sample that the #DEFINE compiler directive is specified before the #IF_DEFINED and #END_IF compiler directives. When #IF_DEFINED and #IF_NOT_DEFINED compiler directives are specified in include files, the include file statements (defined by the #INCLUDE compiler directive) need to be declared after the #DEFINE compiler directive statements.</p>
#DISABLE_WARNING	<p>This compiler directive disables a specified warning message from being displayed after the program is compiled.</p> <p>Syntax:</p> <pre>#DISABLE_WARNING warning#</pre> <p>For example, to disable the following warning:</p> <pre>WARNING: C:\Temp\AMXLoader\AMX home Autopatch Switcher.axi(1191): C10571: Converting type [INTEGER] to [SINTEGER]</pre> <p>Add the following to the AXS file to disable the "C10571" warning:</p> <pre>#DISABLE_WARNING 10571</pre> <p>NOTE: Do not include the "C" prefix from the warning message.</p>
#ELSE	<p>This directive specifies a counter condition; used optionally in conjunction with #IF_DEFINED and #IF_NOT_DEFINED.</p>
#END_IF	<p>This directive marks the end of an #IF_DEFINED or #IF_NOT_DEFINED code block.</p>
#IF_DEFINED	<p>This directive defines conditional compilation. The code following the #IF_DEFINED and before #ELSE (or before #END_IF, if #ELSE is not present) is compiled only if a symbol is defined (see #DEFINE above). If a symbol is not defined and the #ELSE directive is present, the code following #ELSE and before #END_IF is compiled instead.</p> <pre>#IF_DEFINED symbol // code block #else // code block #endif</pre>
#IF_NOT_DEFINED	<p>Defines conditional compilation similar to #IF_DEFINED. The code following the #IF_NOT_DEFINED and before #ELSE (or before #END_IF, if #ELSE is not present) is compiled only if symbol is not defined (see #DEFINE above). If a symbol is defined and the #ELSE directive is present, the code following #ELSE and before #END_IF is compiled instead.</p> <pre>#IF_NOT_DEFINED symbol // code block #else // code block #endif</pre>
#INCLUDE	<p>To include a file in a program, use the keyword #INCLUDE followed by the filename in single quotes:</p> <pre>DEFINE_PROGRAM (* Program statements can go here *) #include 'TEST.AXI' (* More program statements can go here *)</pre> <p>When the compiler reaches the #INCLUDE statement, it jumps into the specified file and continues compiling. When it has reached the end of that file, it comes back to the line following the #INCLUDE statement and continues compiling.</p>
#WARN	<p>Displays a warning message after the program is compiled. Its primary purpose is to remind you of certain conditions related to the program.</p> <pre>#WARN 'This code is obsolete' #warn 'This code is obsolete'</pre>

Array Keywords

Overview

NetLinx allows arrays of any data type supported by the language as well as arrays of user-defined structures and classes.

- If an initialization statement is included in the variable declaration, the array dimension is not required.
- If the array dimension is omitted, both the maximum and effective length is set to the length needed to hold the data contained in the initialization string.

```
CHAR          STRING[ ]      = 'character string'
WIDECHAR      WideString[ ]  = 'wide character string'
INTEGER       IntegerNum[ ]  = {1, 2, 3, 4, 5}
SINTEGER      SINTEGERNum[ ] = {-1, 5, -6}
LONG          LONGNum[ ]     = {$FFFF, 0, 89000}
SLONG         SLONGNum[ ]    = {-99000, 50, 100, 100000}
FLOAT         FloatingNum[ ] = {1.0, 20000.0, 17.5, 80.0}
DOUBLE        DoubleNum[ ]   = {1.0e28, 5.12e-6, 128000.0}
```

String expressions can be used initialization statements only if each byte is separated by a comma:

```
CHAR sProjOn[] = {$02,'P','O','N',$03}
```

The initialization statement for a single dimension character string is enclosed in single quotes, whereas data for other types is enclosed in braces. In the case of a multidimensional character string, the strings in the initialization statement are separated by commas and enclosed in braces.

Example:

```
DEFINE_VARIABLE
CHAR StringTable_3[3][5]=
{
  {'STR 1'},
  {'STR 2'},
  {'STR 3'},
}
```

For multidimensional array types, the data pertaining to each dimension is delimited using braces, as shown below:

```
INTEGER Num2D[ ][ ] = {{1, 3}, {2, 4}, {7, 8}}
(* This sets the dimensions to Num2D[3][2] *)
```

The "=" operator can be used to assign a one dimensional array to another.

```
Array1 = Array2
```

The one dimensional arrays must match type. The size of each dimension of the destination array must be greater than or equal to the corresponding array being assigned; otherwise the contents of the array being assigned is truncated to fit into the destination array. If a type mismatch is detected the compiler will issue an appropriate warning.

The lengths of an array are determined by calling `LENGTH_ARRAY` and `MAX_LENGTH_ARRAY`.

- `LENGTH_ARRAY` returns the effective length of a dimension of an array: the length set implicitly through array initialization or explicitly through a call to `SET_LENGTH_ARRAY`.
- `MAX_LENGTH_ARRAY` is used to determine the maximum length of a dimension of an array.

Changing an element in array does not change its length. `SET_LENGTH_ARRAY` is used to change the effective length of an array when necessary, such as when you've added elements via a `FOR` loop.

Example:

```
DEFINE_VARIABLE
INTEGER Len
INTEGER Len1
INTEGER Len2
INTEGER Array1[] = {3, 4, 5, 6, 7}
INTEGER Array2[10] = {1, 2}
DEFINE_START
Len = MAX_LENGTH_ARRAY(Array1) // Len = 5
Len = MAX_LENGTH_ARRAY(Array2) // Len = 10
// LENGTH_ARRAY is called to determine the effective length of Array1
// and Array2.
// This value is set automatically when the arrays are initialized.
Len1 = LENGTH_ARRAY(Array1) // Len1 = 5
Len2 = LENGTH_ARRAY(Array2) // Len2 = 2
FOR (Len = 1; Len <= Len1; Len++)
{
  ARRAY2[Len2+Len] = Array1[Len]
}
SET_LENGTH_ARRAY(Array2, Len2 + Len1) // Set Array2 length to new length end
```

Multi-dimension arrays cannot be copied directly to another. Use FOR or WHILE loops to copy them at the lowest dimension.

Example:

```
DEFINE_VARIABLE
CHAR ARRAY1[2][10] = {'hello ','goodbye'}
CHAR ARRAY2[2][10] = {'i am the ','walrus'}
INTEGER INDEX
DEFINE_PROGRAM
WAIT 20
{
  FOR (INDEX = 1; INDEX <=2; INDEX++)
  {
    ARRAY2[INDEX] = ARRAY1[INDEX]
  }
  SEND_STRING 0,"ARRAY2[1],ARRAY2[2]"
}
// end
```

Multi-Dimensional Arrays

Any of the single dimension array types listed above can be used to define an array of n-dimensions.

- A 2-dimensional array is simply a collection of 1-dimensional arrays;
- a 3-dimensional array is a collection of 2-dimensional arrays, and so forth.

Here's an example:

```
INTEGER Num1D[10]           // [Column]
INTEGER Num2D[5][10]       // [Row][Column]
INTEGER Num3D[2][5][10]    // [Table][Row][Column]
```

One way to view these arrays is to think of Num2D as being a collection of five Num1D's and Num3D as being a collection of two Num2D's. When referencing elements of the above arrays:

```
Num1D[1]           refers to the 1st element
Num2D[1]           refers to the 1st row
Num2D[1][1]        refers to the 1st element of the 1st row
Num3D[1]           refers to the 1st table
Num3D[1][1]        refers to the 1st row of the 1st table
Num3D[1][1][1]     refers to the 1st element of the 1st row of the 1st table
```

The following operations are legal:

```
Num2D[2] = Num1D
Num2D[5][5] = Num1D[5]
Num3D[2] = Num2D
Num3D[2][1] = Num1D
Num3D[2][1][1] = Num1D[1]
```

LENGTH_ARRAY and MAX_LENGTH_ARRAY are used to determine the effective and maximum lengths of multidimensional arrays, as shown in the following examples:

```
INTEGER Len
INTEGER My3DArray[5][3][4]
Len = MAX_LENGTH_ARRAY(My3DArray) // Len = 5
Len = MAX_LENGTH_ARRAY(My3DArray[1]) // Len = 3
Len = MAX_LENGTH_ARRAY(My3DArray[1][1]) // Len = 4
INTEGER Len
INTEGER My3DArray[5][3][4] =
{
  {
    {1,2,3,4},
    {5,6,7,8},
    {9,10,11}
  },
  {
    {13,14}
  }
}
Len = LENGTH_ARRAY(My3DArray) // Len = 2, number of tables *)
Len = LENGTH_ARRAY(My3DArray[2]) // Len = 1, number of rows in table 2 *)
Len = LENGTH_ARRAY(My3DArray[1][3]) // Len = 3, number of columns in table 1, row 3 *)
```

Array Keywords

Array Keywords	
LENGTH_ARRAY	<p>This function returns the effective length of a dimension of an array, implicitly through array initialization or array manipulation operations, or explicitly through a call to the function SET_LENGTH_ARRAY.</p> <pre>LONG LENGTH_ARRAY (<type> Array[])</pre> <p>Parameters:</p> <ul style="list-style-type: none"> • <type>: May be any intrinsic or user-defined data type • Array: An array of any type. <p>Result: The effective (or working) length of the array.</p> <pre>INTEGER Len INTEGER Array1[] = {3, 4, 5, 6, 7} INTEGER Array2[] = {1, 2} INTEGER My3DArray[5][3][4] = { { {1,2,3,4}, {5,6,7,8}, {9,10,11} } { {13,14} } } Len = LENGTH_ARRAY(Array1) // Len = 5 Len = LENGTH_ARRAY(Array2) // Len = 2 Len = LENGTH_ARRAY(My3DArray) (* Len = 2, the number of tables *) Len = LENGTH_ARRAY(My3DArray[2]) (* Len = 1, the number of rows in table 2 *) Len = LENGTH_ARRAY(My3DArray[1][3]) (* Len = 3, the number of columns in table 1, row 3 *)</pre> <p>See SET_LENGTH_ARRAY, on page 32, for more information.</p>
MAX_LENGTH_ARRAY	<p>This function returns the maximum length of a dimension of an array.</p> <pre>LONG MAX_LENGTH_ARRAY (<type> Array[])</pre> <p>Parameters:</p> <ul style="list-style-type: none"> • <type>: May be any intrinsic or user-defined data type. • Array: An array of any type. <p>Result: The length of the specified dimension of Array.</p> <pre>FLOAT FPArray[10] LONG NumArray[5][3][4] Len = MAX_LENGTH_ARRAY(FPArray) // Len = 10 Len = MAX_LENGTH_ARRAY(NumArray) // Len = 5 Len = MAX_LENGTH_ARRAY(NumArray[1]) // Len = 3 Len = MAX_LENGTH_ARRAY(NumArray[1][1]) // Len = 4</pre>
SET_LENGTH_ARRAY	<p>This function sets the effective length of a dimension of an array.</p> <pre>Set_Length_Array (<type> Array[], LONG Len)</pre> <p>Parameters:</p> <ul style="list-style-type: none"> • <type>: May be any intrinsic or user-defined data type. • Array: Array of any type • Len: Value to assign as the length <pre>SET_LENGTH_ARRAY(NumArray, 5)</pre>

Arrays are limited by their inability to have multiple data-types within one array. NetLinx supports *Structures* to remove this limitation. Structures group different data types together as one data unit. Refer to the *Structure Keywords* on page 130 for more information.

Audit Keywords

NetLinx supports the following Audit keywords:

Audit Keywords	
AUDIT_NETLINUX_GENERIC_EVENT	<p>This function generates an audit record to the persistent audit trail containing the specified NetLinx Device D:P:S and user name to associate with the audit record and a text message to include in the audit record.</p> <p>Syntax: <code>sinteger AUDIT_NETLINUX_GENERIC_EVENT(DEV device, char username[], char msg[])</code></p> <p>Returns: 0 - Successful audit -1 - Audit failed</p>
AUDIT_NETLINUX_SESSION_EVENT	<p>This function generates an audit record in the persistent audit trail containing the specified NetLinx Device D:P:S where the login occurred, the username of the login and the audit type.</p> <p>Syntax: <code>sinteger AUDIT_NETLINUX_SESSION_EVENT(DEV device, char username[], integer audit_type)</code></p> <p>Parameters:</p> <ul style="list-style-type: none"> • <code>audit_type</code> - Can be one of the following values: 0 - Audit Login success 1 - Audit Login fail 2 - Audit Logout <p>Returns: 0 - Successful audit -1 - Audit failed</p>

Authentication Keywords

NetLinx supports the following Authentication keywords:

Authentication Keywords	
VALIDATE_NETLIX_ACCOUNT	<p>This function validates the specified user name and password against the NetLinx Master Controller's internal user account database. For the account to be valid the user name must exist with the matching password and the specified user account must have been set up with ICSP Authorization.</p> <p>Syntax:</p> <pre>sinteger VALIDATE_NETLIX_ACCOUNT (CHAR USERNAME[], CHAR PASSWORD[], LOGIN_INFO_STRUCT INFO)</pre> <p>Parameters:</p> <ul style="list-style-type: none"> • username - A character array containing the user name to validate. • password - A character array containing the password to validate. • info - A return structure of type LOGIN_INFO_STRUCT which contains the following values: <pre>STRUCTURE LOGIN_INFO_STRUCT { INTEGER FAILED_LOGIN_COUNT; CHAR LAST_SUCCESSFUL_LOGIN_DATE[46]; CHAR LAST_SUCCESSFUL_LOGIN_LOCATION[46]; CHAR LAST_FAILED_LOGIN_DATE[46]; CHAR LAST_FAILED_LOGIN_LOCATION[46]; }</pre> <p>Returns:</p> <ul style="list-style-type: none"> 0 - Valid user account. -1 - Username parameter is not a valid string -2 - Password parameter is not a valid string -3 - Invalid user account -4 - User account does not have ICSP Authorization -5 - Third argument is not a LOGIN_INFO_STRUCT -6 - User account matching name is locked out -7 - User account matching name has expired
VALIDATE_NETLIX_ACCOUNT_WITH_PERMISSION	<p>This function validates the specified user name and password against the NetLinx Master Controller's internal user account database. For the account to be valid the user name must exist with the matching password and the specified user account must have been set up with ICSP Authorization.</p> <p>Syntax:</p> <pre>sinteger VALIDATE_NETLIX_ACCOUNT (CHAR USERNAME[], CHAR PASSWORD[], CHAR TYPE[], CHAR PERMISSION[], LAST_LOGIN_INFO INFO)</pre> <p>Parameters:</p> <ul style="list-style-type: none"> • username - A character array containing the user name to validate. • password - A character array containing the password to validate. • type - The authorization type. • permission - The permission type. Valid permission include: Configuration, Console, Diags, EncryptICSP, FTP, HTTP, ICSP, Terminal, AuditLog, User1, User2, User3, and User4 • info - A return structure of type LAST_LOGIN_INFO which contains the following values: <pre>STRUCTURE LAST_LOGIN_INFO { INTEGER FAILED_LOGIN_COUNT; CHAR LAST_SUCCESSFUL_LOGIN_DATE[46]; CHAR LAST_SUCCESSFUL_LOGIN_LOCATION[46]; CHAR LAST_FAILED_LOGIN_DATE[46]; CHAR LAST_FAILED_LOGIN_LOCATION[46]; }</pre> <p>Returns:</p> <ul style="list-style-type: none"> 0 - Valid user account. -1 - Username parameter is not a valid string -2 - Password parameter is not a valid string -3 - Invalid user account -4 - User account does not have ICSP Authorization -5 - Third argument is not a LOGIN_INFO_STRUCT -6 - User account matching name is locked out -7 - User account matching name has expired

Buffer Keywords

NetLinx supports the following Buffer keywords:

Buffer Keywords	
CLEAR_BUFFER	<p>This command sets the contents of the specified text buffer to zero; therefore, subsequent GET_BUFFER_CHAR calls will not return anything. The CLEAR_BUFFER command does not modify the data in the buffer, just the internal length value.</p> <pre>CLEAR_BUFFER Buffer</pre> <p>CLEAR_BUFFER does not delete the data in the buffer; it only sets the length to zero.</p>
CREATE_BUFFER	<p>This keyword creates a buffer and can only appear in the DEFINE_START section of the program.</p> <pre>CREATE_BUFFER DEV, Buffer</pre> <p>CREATE_BUFFER directs NetLinx to place any strings received from the specified device into the specified buffer (character array). When strings are added to the buffer, the length of the buffer is automatically adjusted. If the buffer is full, all bytes in the buffer are shifted to make room for the new string. A buffer can be manipulated in the same way as a character array.</p>
CREATE_MULTI_BUFFER	<p>This keyword is the same as CREATE_BUFFER except that it accepts strings from a range of devices. Two forms of this command are supported.</p> <p>The first form of the command is provided for backward-compatibility; it accepts two device numbers as the range of devices.</p> <pre>CREATE_MULTI_BUFFER FirstDevice, LastDevice, Buffer</pre> <p>Parameters:</p> <ul style="list-style-type: none"> • FirstDevice: First number in the range of devices. • LastDevice: Last number in the range of devices. • Buffer: Text buffer to receive the strings. <p>Each command string placed in the multi-buffer has a three-byte header associated with it:</p> <ul style="list-style-type: none"> • The first header byte (\$FF) marks the start of a new command string. • The second header byte is either the number of the device or the index of the DEV[] member that received the command string. • The third header byte is the length of the string. <pre>\$FF, device number or DEV[] index, length, <string></pre> <p>The second form of the command takes a device array rather than the device number pair.</p> <pre>CREATE_MULTI_BUFFER DeviceSet, Buffer</pre> <p>Parameters:</p> <ul style="list-style-type: none"> • DeviceSet: Set of devices for which the buffer will accept strings. • Buffer: Text buffer to receive the strings. <p>Each command string placed in the multi-buffer has a three-byte header associated with it:</p> <ul style="list-style-type: none"> • The first header byte (\$FF) marks the start of a new command string • The second header byte is the index into the DeviceSet of the device that received the string. • The third header byte is the length of the string. <pre>\$FF, device number or DEV[] index, length, <string></pre> <p>This command is not recommended for use in NetLinx due to its limitations. The main limitations to note are:</p> <ul style="list-style-type: none"> • For the first form of the command, using FirstDevice and LastDevice, only devices using the same port and system will be allowed. The device in between the First Device and Last Device will be the sequential device numbers using the same port and system (i.e. 1:1:0, 2:1:0, 3:1:0, etc...) • For the second form of the command, using DeviceSet, only 255 devices will be allowed in the array. This is required since only one byte is used to represent the DeviceSet index in the return string so it has an upper limit of 255. • Strings from a device longer than 255 bytes will be broken up into multiple "multi" strings within the buffer. For instance, if 300 characters are received from a port, the multi buffer will contain: "\$FF,<index>, 255,<first 255 characters>,\$FF,45,<last 45 characters>" <p>The recommended replacement for CREATE_MULTI_BUFFER and GET_MULTI_BUFFER_STRING is to use a DeviceSet and a DATA_EVENT to capture strings from multiple devices. See GET_MULTI_BUFFER_STRING for more information.</p> <p>An example is shown below:</p> <pre>DEFINE_DEVICE Dev1 = 1:1:0 Dev2 = 1:2:0 Dev3 = 1:3:0 DEFINE_VARIABLE DEV DeviceSet[] = {Dev1, Dev2, Dev3} INTEGER DeviceIndex CHAR DeviceString[1000] DEFINE_EVENT DATA_EVENT[DeviceSet] { STRING: { DeviceIndex = GET_LAST(DeviceSet) DeviceString = DATA.TEXT } }</pre> <p>See GET_MULTI_BUFFER_STRING, for more information.</p>

Buffer Keywords (Cont.)	
GET_BUFFER_CHAR	<p>This keyword removes characters from a buffer.</p> <pre>Result = GET_BUFFER_CHAR (Array)</pre> <p>Array may be either a character array or wide character array; the operation is identical in either case. The result is a CHAR or WIDECHAR value depending on the variable type of Array.</p> <p>GET_BUFFER_CHAR has a two-part operation:</p> <ol style="list-style-type: none"> 1. Retrieve the first character in the buffer. 2. Remove the retrieved character from the buffer and shift the remaining characters by one to fill the gap.
GET_BUFFER_STRING	<p>This function removes characters from a buffer.</p> <pre>Result = GET_BUFFER_STRING (Array, Length)</pre> <p>Array may be either a character array or wide character array; the operation is identical in either case. Length is the number of characters to remove.</p> <p>Result is a CHAR or WIDECHAR value depending on the variable type of Array.</p> <p>GET_BUFFER_STRING has a two-part operation:</p> <ol style="list-style-type: none"> 1. Retrieve <length> number of characters from the buffer. 2. Remove the retrieved character from the buffer and shift the remaining characters up to fill the gap.
GET_MULTI_BUFFER_STRING	<p>To access characters coming into a multi-buffer, you must first use GET_MULTI_BUFFER_STRING to transfer these characters into another array. For example:</p> <pre>Device = GET_MULTI_BUFFER_STRING (Buffer, Array)</pre> <ul style="list-style-type: none"> • The next string in the specified buffer is copied to the specified array. • All three header bytes are stripped before the string is copied. • If CREATE_MULTI_BUFFER was defined using a FirstDevice and LastDevice, the return value Device is the device number (not the Port number) of the card that received the string. • If CREATE_MULTI_BUFFER was defined using a DeviceSet, the return value Device is the device index into the DeviceSet array of the card that received the string.

Channel Keywords

NetLinx supports the following CHANNEL keywords:

CHANNEL Keywords	
COMBINE_CHANNELS	See page 46.
OFF	This keyword is used to turn off a channel or variable. If used with a variable, OFF sets it to zero. OFF[DEVICE, CHANNEL] OFF[(DEVCHAN[])] OFF[Variable]
ON	This keyword is used to turn a channel or variable on. If used with a variable, ON sets it to 1. ON[DEVICE, CHANNEL] ON[(DEVCHAN[])] ON[Variable]
PUSH_CHANNEL	See page 121.
RELEASE_CHANNEL	See page 121.
PUSH_DEVCHAN	See page 121.
RELEASE_DEVCHAN	See page 121.
SET_VIRTUAL_CHANNEL_COUNT	See page 123.
TOTAL_OFF	This keyword turns a channel or variable off. Unlike OFF, TOTAL_OFF turns off the status of a channel or variable that is in a mutually exclusive set.

Clock Manager Keywords

NetLinx supports the following Clock Manager keywords:

Clock Manager Keywords	
CLKMGR_SET_DAYLIGHT_SAVINGS_OFFSET	Sets the Daylight Savings Offset to the specified value. CLKMGR_SET_DAYLIGHTSAVINGS_OFFSET (CONSTANT CLKMGR_TIMEOFFSET_STRUCT T)
CLKMGR_DELETE_USER_DEFINED_TIMESERVER	Deletes the user-defined entry that has its IP-ADDRESS matching the parameter. CLKMGR_DELETE_USERDEFINED_TIMESERVER (CONSTANT CHAR IP[])
CLKMGR_GET_ACTIVE_TIMESERVER	Populates the TIMESERVER structure with the currently active time server's data. CLKMGR_GET_ACTIVE_TIMESERVER (CLKMGR_TIMESERVER_STRUCT T) The function returns a negative SLONG value if it encounters an error.
CLKMGR_GET_DAYLIGHTSAVINGS_OFFSET	Populates the TIMEOFFSET structure with the current Daylight Savings Offset configured. CLKMGR_GET_DAYLIGHTSAVINGS_OFFSET (CLKMGR_TIMEOFFSET_STRUCT T) The function returns a negative SLONG value if it encounters an error.
CLKMGR_GET_END_DAYLIGHTSAVINGS_RULE	Gets a string representation of when Daylight Savings is supposed to end. <ul style="list-style-type: none"> The Fixed-Date rules have the form: "fixed:DAY,MONTH,HH:MM:SS" with all fields as numeric except for the word "fixed". The Occurrence-Of-Day rules have the form: "occurrence:OCCURRENCE, DAY-OF-WEEK,MONTH,HH:MM:SS" with all fields as numeric except for the word "occurrence". DAY-OF-WEEK translates as: <ul style="list-style-type: none"> 1=Sunday 2=Monday 3=Tuesday 4=Wednesday 5=Thursday 6=Friday 7=Saturday
CLKMGR_GET_RESYNC_PERIOD	Returns the Clock Manager's re-sync period in minutes. The default setting is one (1) hour. This setting has no effect if the Clock Manager mode is set to STANDALONE.
CLKMGR_GET_START_DAYLIGHTSAVINGS_RULE	Gets a string representation of when Daylight Savings is supposed to START. <ul style="list-style-type: none"> The Fixed-Date rules have the form: "fixed:DAY,MONTH,HH:MM:SS" with all fields as numeric except for the word "fixed". The Occurrence-Of-Day rules have the form: "occurrence:OCCURRENCE, DAY-OF-WEEK,MONTH,HH:MM:SS" with all fields as numeric except for the word "occurrence". DAY-OF-WEEK translates as: <ul style="list-style-type: none"> 1=Sunday 2=Monday 3=Tuesday 4=Wednesday 5=Thursday 6=Friday 7=Saturday
CLKMGR_GET_TIMESERVERS	Populates the currently configured time server entries from the Clock Manager into the specified TIMESERVER array. CLKMGR_GET_TIMESERVERS (CLKMGR_TIMESERVER_STRUCT T[]) The function returns a negative SLONG value if it encounters an error, otherwise the return value is set to the number of records populated into the CLKMGR_TIMESERVER_STRUCT array.
CLKMGR_GET_TIMEZONE	Returns Timezone as a string in the format: UTC[+ -]HH:MM
CLKMGR_IS_DAYLIGHTSAVINGS_ON	Returns FALSE/0 or TRUE/1. The default setting is FALSE/0.
CLKMGR_IS_NETWORK_SOURCED	Returns FALSE/0 or TRUE/1. The default setting is FALSE/0.
CLKMGR_SET_ACTIVE_TIMESERVER	Sets the time server entry that has the matching IP-ADDRESS to the IP parameter as the active time server entry. CLKMGR_SET_ACTIVE_TIMESERVER (CONSTANT CHAR IP[])
CLKMGR_SET_CLK_SOURCE	Sets the source for the Clock Manager CLKMGR_SET_CLK_SOURCE (CONSTANT INTEGER MODE) Can be set to: CLKMGR_MODE_NETWORK <i>or</i> CLKMGR_MODE_STANDALONE

Clock Manager Keywords (Cont.)	
CLKMGR_SET_DAYLIGHTSAVINGS_MODE	<p>Sets Daylight Savings mode to Off or On.</p> <p><code>CLKMGR_SET_DAYLIGHTSAVINGS_MODE</code> (CONSTANT INTEGER ONOFF)</p> <p>Can be set to:</p> <p>ON/TRUE or OFF/FALSE</p>
CLKMGR_SET_DAYLIGHTSAVINGS_OFFSET	<p>Sets the Daylight Savings Offset to the specified value.</p> <p><code>CLKMGR_SET_DAYLIGHTSAVINGS_OFFSET</code> (CONSTANT CLKMGR_TIMEOFFSET_STRUCT T)</p>
CLKMGR_SET_END_DAYLIGHTSAVINGS_RULE	<p>Sets the END Daylight Savings rule to the specified string which must be in either the Fixed-Date format or the Occurrence-Of-Day format.</p> <p><code>CLKMGR_SET_END_DAYLIGHTSAVINGS_RULE</code> (CONSTANT CHAR RECORD[])</p> <p>The function returns a negative SLONG value if it encounters an error.</p> <p>The Fixed-Date rules have the form:</p> <p>"fixed:DAY,MONTH,HH:MM:SS" with all fields as numeric except for the word "fixed" (e.g.: "fixed:21,3,02:00:00" ==> March 21 @ 02:00:00AM).</p> <p>The Occurrence-Of-Day rules have the form:</p> <p>"occurrence:OCCURRENCE, DAY-OF-WEEK, MONTH, HH:MM:SS" with all fields as numeric except for the word "occurrence"</p> <p>DAY-OF-WEEK translates as:</p> <ul style="list-style-type: none"> • 1=Sunday • 2=Monday • 3=Tuesday • 4=Wednesday • 5=Thursday • 6=Friday • 7=Saturday <p>(e.g.: "occurrence:3,1,10,02:00:00" ==> 3rd Sunday in October @ 02:00:00AM).</p>
CLKMGR_SET_RESYNC_PERIOD	<p>Sets the re-sync period to the specified minute value.</p> <p><code>CLKMGR_SET_RESYNC_PERIOD</code> (CONSTANT INTEGER PERIOD)</p> <p>The upper bound is 480 minutes (i.e., 8 hours).</p>
CLKMGR_SET_START_DAYLIGHTSAVINGS_RULE	<p>Sets the START Daylight Savings rule to the specified string which must be in either the Fixed-Date format or the Occurrence-Of-Day format.</p> <p><code>CLKMGR_SET_START_DAYLIGHTSAVINGS_RULE</code> (CONSTANT CHAR RECORD[])</p> <p>The function returns a negative SLONG value if it encounters an error.</p> <p>The Fixed-Date rules have the form:</p> <p>"fixed:DAY,MONTH,HH:MM:SS" with all fields as numeric except for the word "fixed" (e.g.: "fixed:21,3,02:00:00" ==> March 21 @ 02:00:00AM).</p> <p>The Occurrence-Of-Day rules have the form:</p> <p>"occurrence:OCCURRENCE, DAY-OF-WEEK, MONTH, HH:MM:SS" with all fields as numeric except for the word "occurrence"</p> <p>DAY-OF-WEEK translates as:</p> <ul style="list-style-type: none"> • 1=Sunday • 2=Monday • 3=Tuesday • 4=Wednesday • 5=Thursday • 6=Friday • 7=Saturday <p>(e.g.: "occurrence:3,1,10,02:00:00" ==> 3rd Sunday in October @ 02:00:00AM).</p>
CLKMGR_SET_TIMEZONE	<p>Sets the Timezone.</p> <p><code>CLKMGR_SET_TIMEZONE</code> (CONSTANT CHAR TIMEZONE[])</p> <p>Input string must have the correct format:</p> <p>UTC[+ -]HH:MM</p>

Combine & Uncombine Keywords

Overview

The Access language supports the concept of combining several panels to make them behave as if they were one panel, in order to simplify code. This feature allows the combination of functionally identical devices, such as identically programmed Touch Panels and Software Panels. When the program references one of these devices, all other combined device arrays are also referenced. In Access, device combine operations are done in the DEFINE_COMBINE section of the code, and can produce mixed results (any time one or more panels are dropped off-line).

NetLinX further addresses the issues surrounding combining panels (and their associated channels and levels), and allows you to combine and un-combine panels on the fly. The primary difference between the way that the Access and NetLinX languages handles combine operations is that NetLinX utilizes the concept of the virtual device. A virtual device is a device that does not physically exist but merely represents one or more devices.

NOTE: *If you have combined Devices, Levels and/or Channels, they must be un-combined before they can be added as part of a new COMBINE function.*

Combining and Un-Combining Devices

To approach setting up combine and un-combine operations in NetLinX, let's first look at the way that combine operations are done in the Access language.

Combining Devices

The example below illustrates how an Access program combines three touch panels to act as one.

```
DEFINE_DEVICE
TP1 = 128
TP2 = 129
TP3 = 130

DEFINE_COMBINE
(TP1, TP2, TP3)

DEFINE_PROGRAM
RELEASE[TP1,1]
{
    (*Do Something*)
}
```

NOTE: *The code shown in the Access example will not work in NetLinX, due to incompatibilities between the languages (i.e. Access does not allow virtual devices, which are required for Combine/Uncombine operations in NetLinX).*

This combines a common level to each of three devices TP1 , TP2 , and TP3 . If an input change occurs on any of the three devices, Access sees the input as coming only from the first device in the list (TP1). If button [TP2,12] is pressed, Access will see the input coming from [TP1,12] due to the combination. Likewise, any output change sent to any device in the list will automatically be sent to all devices in the list. This includes level changes. For example, the statement ON [TP1,50] will turn on channel 50 for all three devices in the list.

Now let's see how the code example shown above would translate into NetLinX:

```
DEFINE_COMBINE
DEFINE_DEVICE

VIRTUAL1 = 33000
TP1 = 128
TP2 = 129
TP3 = 130

DEFINE_COMBINE
(VIRTUAL1, TP1, TP2, TP3)

DEFINE_PROGRAM
RELEASE[VIRTUAL1,1]
{
    (*Do Something*)
}
```

Note the use of the virtual device (VIRTUAL1) in the above example. Combine operations in NetLinX require that the first device in the list (the primary device) must be a virtual device. By specifying a virtual device as the primary device in a DEFINE_COMBINE statement, NetLinX code can be written targeting the virtual device, but effectively operating on each physical device. Furthermore, since a virtual device is not an actual physical device, the primary device cannot be taken off-line or removed from the system (which avoids the potential problems that occurred in Access). The virtual device's address number must be in the range of 32768 to 36863.

The example above combines the three touch panel devices: TP1, TP2 and TP3. Whenever an input change occurs on any of the three devices, NetLinx detects the input as coming only from VIRTUAL1. For example, if button [TP3, 5] is pressed, NetLinx sees input coming from [VIRTUAL1, 5] as a result of the combination.

Output changes (including level changes) sent to any device in the list will automatically be sent to all devices in the list. For instance, the statement: ON [VIRTUAL1, 50] turns on channel 50 on all three panels and OFF [VIRTUAL1, 10] turns off channel 10 on all three panels.

The example below illustrates the use of a device array (Dev[]), instead of specifying the individual devices (TP1, TP2, and TP3). Device arrays can further simplify your code and allow you to dynamically combine/un-combine devices. Any input events for any device in the array will appear to the program as coming from the virtual device. Output changes, directed to the virtual device or any device in the array, are sent to all devices in the array. Here's a syntax example:

```
COMBINE_DEVICES (VIRTUAL1, TP1, TP2, TP3)
```

In addition to virtual devices and device arrays, NetLinx contains several new keywords for combine and un-combine operations:

- COMBINE_DEVICES, UNCOMBINE_DEVICES
- COMBINE_LEVELS, UNCOMBINE_LEVELS
- COMBINE_CHANNELS, UNCOMBINE_CHANNELS

NOTE: Refer to the *Combining and Un-Combining Levels* section on page 42 for more information.

Un-combining Devices

UNCOMBINE_DEVICES reverses the effect of COMBINE_DEVICES. All combines related to the specified virtual device are disabled. A syntax example is:

```
UNCOMBINE_DEVICES (VDC)
```

Parameters:

VDC The virtual device-channel passed to COMBINE_DEVICES.

```
COMBINE_DEVICES (VDC, DCSet)
```

```
.
```

```
.
```

```
UNCOMBINE_DEVICES (VDC)
```

The following NetLinx code example illustrates combining and un-combining the panels from the previous example:

NOTE: *Input and output changes occurring on non-combined panels will not affect combined panels, and vice versa.*

```
DEFINE_DEVICE
VIRTUAL1 = 33000
TP1 = 128
TP2 = 129
TP3 = 130

TP4 = 131

DEFINE_PROGRAM
(* Activate dynamic device combine*)
RELEASE[TP4,1]
{
    COMBINE_DEVICES(VIRTUAL1, TP1, TP2, TP3)
}
(*Remove dynamic device combine*)

RELEASE[TP4,1]
{
    UNCOMBINE_DEVICES(VIRTUAL1)
}
(*Pushes come here when a combine is active*)

RELEASE[VIRTUAL1,1]
{
    (*Do Something*)
}
(*This will only see pushes when combine is NOT active*)
RELEASE[TP1,1]
{
    (*Do Something*)
}
```

Combining and Un-Combining Levels

To approach setting up level combine and un-combine operations in NetLinX, let's first look at the way that level combine operations are done in the Access language. The example below illustrates how an Access program would combine three Touch Panel levels to act as one.

NOTE: *The code shown in the Access example will not work in NetLinX, due to incompatibilities between the languages (i.e. Access does not allow virtual devices, which are required for Combine/Uncombine operations in NetLinX).*

```
DEFINE_DEVICE
TP1 = 128
TP2 = 129
TP3 = 130

DEFINE_CONNECT_LEVEL
(TP1,1, TP2,1, TP3,1)
```

TP1, TP2, and TP3 are devices; this example combines Level 1 on each device. If a level change occurs on any of the three devices, Access sees the level coming only from the first device in the list (TP1). Likewise, any level change sent to any device in the list will automatically be sent to all devices in the list. Now let's see how the code example shown above would translate into NetLinX. This is code that would function correctly within a NetLinX system, but still uses the Access-based.

```
DEFINE_CONNECT_LEVEL
DEFINE_DEVICE
VIRTUAL1 = 33000
TP1 = 128
TP2 = 129
TP3 = 130

DEFINE_CONNECT_LEVEL
(VIRTUAL1, 1, TP1,1, TP2,1, TP3,1)
```

The example above combines the levels for the three touch panels: TP1, TP2 and TP3. Whenever a level change occurs on any of the three devices, NetLinX detects the level as coming only from VIRTUAL1.

The example below illustrates the use of a device array (Dev[]), instead of specifying the individual devices (TP1, TP2 and TP3). Device arrays further simplify code and allow you to dynamically combine/un-combine levels. Any input events for any device in the array will appear to the program as coming from the virtual device. Output changes, directed to the virtual device or any device in the array, are sent to all devices in the array. The syntax must follow one of these two forms:

```
DEFINE_CONNECT_LEVEL
(Vdevice1, 1, DEVLEV [ ])
- or -
DEFINE_CONNECT_LEVEL
(VDEVLEV, DEVLEV [ ])
```

Combining Levels

COMBINE_LEVELS connects a single device-level array (DEVLEV[]) to a DEVLEV array. Any element in a DEVLEV array appears to come from the virtual device-level representing the group, and output to any element in a DEVLEV array is directed to all elements in the group. Here's a syntax example:

```
COMBINE_LEVELS (DEVLEV VDLSET, DEVLEV[ ] DLSETS)
```

Parameters:

- VDLSET Virtual device-level. Each element will represent one device-level combine group.
- DLSETS Device-level sets containing the device-level pairs to combine.
Corresponding elements in each set are combined with the corresponding element in the virtual device-level array.

Un-combining Levels

UNCOMBINE_LEVELS undoes the effect of COMBINE_LEVELS. All combines related to the specified virtual device-level are disabled.

NOTE: *Input and output changes occurring on non-combined panels will not affect combined panels, and vice versa.*

```
UNCOMBINE_LEVELS (DEVLEV)
```

Parameters:

- VDL The virtual device-level passed to COMBINE_LEVELS.
- DEVLEV The device-level passed to COMBINE_LEVELS.

```
COMBINE_LEVELS (VDL, DLSet)
.
.
UNCOMBINE_LEVELS (VDL)
```

The NetLinX code example below illustrates how to dynamically combine and un-combine levels.

```
DEFINE_DEVICE
VIRTUAL1 = 33000
TP1 = 128
TP2 = 129
TP3 = 130
TP4 = 131
```

```

DEFINE_PROGRAM
  (*Activate dynamic level combine*)
RELEASE[TP4,1]
{
  COMBINE_LEVELS(VIRTUAL1,1,TP1,1,TP2,1,TP3,1)
}
  (*Remove dynamic level combine*)
RELEASE[TP4,1]
{
  UNCOMBINE_LEVELS(VIRTUAL1,1)
}

```

Combining and Un-Combining Channels

Combining Channels

COMBINE_CHANNELS connects a single virtual device-channel to one or more channels on another device (or devices). Stated another way, COMBINE_CHANNELS combines a single virtual DEVCHAN or [DEV,CHAN] pair to one or more DEVCHANS or [DEV,CHAN] pairs. Any element in a DEVCHAN[] set combined appears to come from the virtual device-channel representing the group, and output to the virtual device-channel is directed to all elements in the DEVCHAN[] set.

```
COMBINE_CHANNELS (DEVCHAN VDC, DEVCHAN[ ] DCSets)
```

Parameters:

VDC	Virtual device-channel that represents one device-channel combine group.
DCSets	Device-channel array containing the device-channel pairs to combine. The VDC is combined with each element in the device-channel array.

Un-combining Channels

UNCOMBINE_CHANNELS reverses the effect of COMBINE_CHANNELS. All combines related to the specified virtual device-channel are disabled.

```
UNCOMBINE_CHANNELS (DEVCHAN VDC)
```

Parameters:

VDC	The virtual device-channel passed to COMBINE_CHANNELS.
-----	--

```
UNCOMBINE_CHANNELS (VDC)
```

NOTE: When using *COMBINE_XXXX* and *UNCOMBINE_XXXX* functions dynamically based upon a button event, the combining and combining must be done on the release of the button (the active event must be complete before a *COMBINE_XXXX* or *UNCOMBINE_XXXX* function is invoked).

The examples in the program below demonstrate the use of COMBINE_CHANNELS and UNCOMBINE_CHANNELS:

```

PROGRAM_NAME='CombineChannelsExample'
DEFINE_DEVICE // common devices for all examples below
dvTP = 128:1:0
dvREL10 = 301:1:0
dvIO10 = 310:1:0
vdvControl = 33000:1:0
// example of combining a DEVCHAN set to a virtual [DEV,CHAN] pair
DEFINE_VARIABLE
DEVCHAN dc1[] = {{dvIO10,1},{dvREL10,1},{dvTP,1}}
DEFINE_EVENT
BUTTON_EVENT[dvTP,11] // COMBINE_CHANNELS 1
{
  RELEASE:
  {
    COMBINE_CHANNELS (vdvControl,1,dc1)
  }
}
BUTTON_EVENT[dvTP,12] // UNCOMBINE_CHANNELS 1
{
  RELEASE:
  {
    UNCOMBINE_CHANNELS (vdvControl,1)
  }
}
BUTTON_EVENT[vdvControl,1] // this will work when the COMBINE_CHANNELS above is invoked
{
  PUSH:
  {
    TO[BUTTON.INPUT]
  }
}

```

```

// example of combining individual DEVCHANs to a virtual [DEV,CHAN] pair
DEFINE_VARIABLE
DEVCHAN dc2[] = {{dvIO10,2},{dvREL10,2},{dvTP,2}}
DEFINE_EVENT
BUTTON_EVENT[dvTP,13]      // COMBINE_CHANNELS 2
{
    RELEASE:
    {
        COMBINE_CHANNELS (vdvControl,2,dc2[1],dc2[2],dc2[3])
    }
}
BUTTON_EVENT[dvTP,14]      // UNCOMBINE_CHANNELS 2
{
    RELEASE:
    {
        UNCOMBINE_CHANNELS (vdvControl,2)
    }
}
BUTTON_EVENT[vdvControl,2] // this will work when the COMBINE_CHANNELS above is invoked
{
    PUSH:
    {
        TO[BUTTON.INPUT]
    }
}
// example of combining individual [DEV,CHAN] pairs to a virtual [DEV,CHAN] pair
DEFINE_VARIABLE
DEVCHAN dc3[] = {{dvIO10,3},{dvREL10,3},{dvTP,3}}
DEFINE_EVENT
BUTTON_EVENT[dvTP,15]      // COMBINE_CHANNELS 3
{
    RELEASE:
    {
        COMBINE_CHANNELS (vdvControl,3,
            dc3[1].DEVICE,
            dc3[1].CHANNEL,
            dc3[2].DEVICE,
            dc3[2].CHANNEL,
            dc3[3].DEVICE,
            dc3[3].CHANNEL)
    }
}
BUTTON_EVENT[dvTP,16]      // UNCOMBINE_CHANNELS 3
{
    RELEASE:
    {
        UNCOMBINE_CHANNELS (vdvControl,3)
    }
}
BUTTON_EVENT[vdvControl,3] // this will work when the COMBINE_CHANNELS above is invoked
{
    PUSH:
    {
        TO[BUTTON.INPUT]
    }
}
// example of combining a DEVCHAN set to a virtual DEVCHAN
DEFINE_VARIABLE
DEVCHAN vdc4 = {vdvControl,4}
DEVCHAN dc4[] = {{dvIO10,4},{dvREL10,4},{dvTP,4}}
DEFINE_EVENT
BUTTON_EVENT[dvTP,17]      // COMBINE_CHANNELS 4
{
    RELEASE:
    {
        COMBINE_CHANNELS (vdc4,dc4)
    }
}
BUTTON_EVENT[dvTP,18]      // UNCOMBINE_CHANNELS 4
{
    RELEASE:
    {
        UNCOMBINE_CHANNELS (vdc4)
    }
}

```

```

BUTTON_EVENT[vdc4]          // this will work when the COMBINE_CHANNELS above is invoked
{
    PUSH:
    {
        TO[BUTTON.INPUT]
    }
}
// example of combining individual DEVCHANs to a virtual DEVCHAN
DEFINE_VARIABLE
DEVCHAN vdc5 = {vdcControl,5}
DEVCHAN dc5[] = {{dvIO10,5},{dvREL10,5},{dvTP,5}}
DEFINE_EVENT
BUTTON_EVENT[dvTP,19]      // COMBINE_CHANNELS 5
{
    RELEASE:
    {
        COMBINE_CHANNELS (vdc5,dc5[1],dc5[2],dc5[3])
    }
}
BUTTON_EVENT[dvTP,20]      // UNCOMBINE_CHANNELS 5
{
    RELEASE:
    {
        UNCOMBINE_CHANNELS (vdc5)
    }
}

BUTTON_EVENT[vdc5]          // this will work when the COMBINE_CHANNELS above is invoked
{
    PUSH:
    {
        TO[BUTTON.INPUT]
    }
}
// example of combining individual [DEV,CHAN] pairs to a virtual DEVCHAN
DEFINE_VARIABLE
DEVCHAN vdc6 = {vdcControl,6}
DEVCHAN dc6[] = {{dvIO10,6},{dvREL10,6},{dvTP,6}}
DEFINE_EVENT
BUTTON_EVENT[dvTP,21]      // COMBINE_CHANNELS 6
{
    RELEASE:
    {
        COMBINE_CHANNELS (vdc6,
            dc6[1].DEVICE,
            dc6[1].CHANNEL,
            dc6[2].DEVICE,
            dc6[2].CHANNEL,
            dc6[3].DEVICE,
            dc6[3].CHANNEL)
    }
}
BUTTON_EVENT[dvTP,16]      // UNCOMBINE_CHANNELS 6
{
    RELEASE:
    {
        UNCOMBINE_CHANNELS (vdc6)
    }
}
BUTTON_EVENT[vdc6]          // this will work when the COMBINE_CHANNELS above is invoked
{
    PUSH:
    {
        TO[BUTTON.INPUT]
    }
}
// end

```

COMBINE & UNCOMBINE Keywords

NetLinx supports the following COMBINE and UNCOMBINE keywords:

COMBINE & UNCOMBINE Keywords	
COMBINE_CHANNELS	<p>This command connects a single virtual device-channel to one or more channels on another device (or devices). Any element in a DEVCHAN[] set appears to come from the virtual device-channel representing the group, and output to the virtual device-channel is directed to all elements in the DEVCHAN[] set.</p> <pre>COMBINE_CHANNELS (DEVCHAN VDC, DEVCHAN[] DCSETS)</pre> <p>Parameters:</p> <ul style="list-style-type: none"> VDC: Virtual device-channel that represents one device-channel combine group. DCSETS: Device-channel array containing the device-channel pairs to combine. Each element in each set is combined with the virtual device-channel.
COMBINE_DEVICES	<p>This keyword defines the combination of functionally identical devices, such as identically programmed touch panels. When the program references one of these devices, all other combined devices in the array are also referenced. The devices in a given array must be enclosed in parentheses. A virtual device is one that does not actually exist but merely represents one or more physical devices.</p> <p>The first device in the list (the primary device) must be a virtual device. By specifying a virtual device as the primary device, NetLinx code can target the virtual device but have the effect of operating on each physical device. Furthermore, since a virtual device is not an actual physical device, the primary device cannot be taken off-line or removed from the system. An example of virtual devices is shown below:</p> <pre>COMBINE_DEVICES (VIRTUAL1, TP1, TP2, TP3)</pre> <p>The example above combines the three touch panel devices: TP1, TP2 and TP3. Whenever an input change occurs on any of the three devices, NetLinx detects the input as coming only from VIRTUAL1. For example, if button [TP3, 5] is pressed, NetLinx sees input coming from [VIRTUAL1, 5] as a result of the combination.</p> <p>Output changes (including level changes) sent to any device in the list will automatically be sent to all devices in the list. For instance, ON[VIRTUAL1, 50] will turn on channel 50 on all three panels and OFF[VIRTUAL1, 10] will turn off channel 10 on all three panels.</p> <p>The example below is equivalent to the first except that it uses a device array (Dev[]) instead of specifying the individual devices (TP1, TP2, and TP3). Any input events for any device in the array will appear to the program as coming from the virtual device. Output changes directed to the virtual device or any device in the array are sent to all devices in the array.</p> <pre>COMBINE_DEVICES (VIRTUAL1, Dev[])</pre> <p>When using a device array, the array can be manipulated at run-time to add or remove devices. A device that is added to the array is combined with the others and a device that is removed is uncombined.</p> <p>The process of adding or removing devices does not require the system to be powered down and restarted.</p>
COMBINE_LEVELS	<p>This keyword connects a single device-level array (DEVLEV[]) to a DEVLEV array. Any element in a DEVLEV array appears to come from the virtual device-level representing the group, and output to any element in a DEVLEV array is directed to all elements in the group.</p> <pre>COMBINE_LEVELS (DEVLEV VDLSET, DEVLEV[] DLSETS)</pre> <p>Parameters:</p> <ul style="list-style-type: none"> VDLSET: Virtual device-level sets; each element represents one device-level combine group. DLSETS: Device-level sets containing the device-level pairs to combine. Corresponding elements in each set are combined with the corresponding element in the virtual device-level array.
DEFINE_COMBINE	<p>This keyword defines the combination of functionally identical devices, such as identically programmed touch panels. When the program references one of these devices, all other combined devices are also referenced. The devices in a given combine must be enclosed in parentheses. The first device in the list (the primary device) must be a virtual device.</p> <pre>DEFINE_COMBINE(VDevice, Panel1, Panel2, Panel3)</pre> <p>The example below uses a device array (DEV[]) instead of specifying the individual devices (Panel1, Panel2, and Panel3). Any input events for any device in the array will appear to the program as coming from the virtual device. Output changes directed to the virtual device or any device in the set is sent to all devices in the array.</p> <pre>DEFINE_COMBINE(VDevice, DEV[])</pre> <p>See the <i>Combine & Uncombine Keywords</i> on page 40 for more information on virtual devices and device arrays.</p>
DEFINE_CONNECT_LEVEL	<p>This keyword defines level connections. A single connection is defined by listing the device-level pairs inside parentheses. The first level in the list (the primary level) must be a virtual level (a level on a virtual device). A virtual level does not actually exist but merely represents one or more levels on physical devices.</p> <p>The example below combines the levels [Device1, Level1] and [Device2, Level2].</p> <pre>(VDevice, Level1, Device1, Level1, Device2, Level1)</pre> <p>The next example combines all levels in the device-level array. Changes to any level listed in the connection will automatically be reflected in the other levels so that all level values are the same.</p> <pre>DEFINE_CONNECT_LEVEL(VDevLev, MyDL[])</pre> <p>By specifying a virtual level as the primary level, NetLinx code targets the virtual level but operates on each physical level. Since the primary level is virtual, the primary device (a virtual device) cannot be taken off-line or removed from the system.</p>
UNCOMBINE_CHANNELS	<p>This keyword reverses the effect of COMBINE_CHANNELS. All combines related to the specified virtual device-channel are disabled.</p> <pre>UNCOMBINE_CHANNELS VDC</pre> <p>Parameters:</p> <ul style="list-style-type: none"> VDC: The virtual device-channel passed to COMBINE_CHANNELS.

COMBINE & UNCOMBINE Keywords (Cont.)	
UNCOMBINE_DEVICES	<p>This keyword reverses the effect of <code>COMBINE_DEVICES</code>. All combines related to the specified virtual device are disabled.</p> <pre>UNCOMBINE_DEVICES VD</pre> <p>Parameters:</p> <ul style="list-style-type: none">• <code>VD</code>: The virtual device passed to <code>COMBINE_DEVICES</code>.
UNCOMBINE_LEVELS	<p>This keyword reverses the effect of <code>COMBINE_LEVELS</code>. All combines related to the specified virtual device-level are disabled.</p> <pre>UNCOMBINE_LEVELS VDL</pre> <p>Parameters:</p> <ul style="list-style-type: none">• <code>VDL</code>: The virtual device-channel passed to <code>COMBINE_LEVELS</code>.

Compiler Keywords

NetLinx supports the following Compiler keywords:

Compiler Keywords	
__DATE__	__DATE__ is replaced by a string (mm/dd/yy) containing the date of compilation. The example below sends the date of compilation to a variable text button on a touch panel. <code>SEND_COMMAND TP, "'!T',1,__DATE__"</code>
__FILE__	At compile time, this keyword is replaced with a string that contains the filename of the currently executing program file.
__LDATE__	At compile time, this keyword is replaced by a string (mm/dd/yyyy), containing the date of \compilation. The example below sends the date of compilation to a variable text button on a touch panel. <code>SEND_COMMAND TP, "'!T',1,__LDATE__"</code>
__LINE__	At compile time, this keyword is replaced by a constant that contains the line number the \keyword is on. <code>SEND_STRING 0,"ITOA(__LINE__)"</code>
__NAME__	At compile time, this keyword is replaced by a string that contains the PROGRAM_NAME \description found on the first line of the program.
__TIME__	At compile time, this keyword is replaced by a string (hh:mm:ss) representing the time of \compilation. The example below sends the time of compilation to a variable text button on a touch panel. <code>SEND_COMMAND TP, "'!T',1,__TIME__"</code>

See page 48 for a listing of Compiler Keywords.

Refer to the *Appendix A - Compiler Warning & Errors* section on page 157 for a listing of Compiler Messages.

Conditional & Loop Keywords

Overview

NetLinx supports the following types of conditional statements and loops:

- Conditional statements:
 - IF...ELSE statements
 - SELECT...ACTIVE statements
 - SWITCH...CASE statements
- Loops:
 - FOR statements
 - WHILE statements
 - LONG_WHILE statements

MEDIUM_WHILE statements are obsolete in NetLinx due to eliminating the timeout of WHILE loops. LONG_WHILE loops now differ from WHILE loops in the way input change notifications are processed during the programming loop. WHILE, MEDIUM_WHILE and LONG_WHILE statements are all accepted syntax to provide compatibility with existing Axxess programs.

Conditionals

IF...ELSE

The IF...ELSE statement provides a structure for conditional branching of program execution. If a condition evaluates to true, the statement(s) associated with it are executed; otherwise, statements are not executed. An example is:

```
IF (<conditional expression 1>)
{
    (* statements for condition 1 *)
}
ELSE IF (<conditional expression 2>)
{
    (* statements for condition 2 *)
}
ELSE
{
    (* statements for all other conditions *)
}
```

Regarding IF statements:

- ELSE IF is optional.
- Braces are generally recommended in all cases but are only required if multiple statements are assigned to a given condition.
- IF statements may be nested to any number of levels.

SELECT...ACTIVE

The SELECT...ACTIVE statement provides a programming structure for selective execution of code blocks based on the evaluation of a series of conditions. The first block whose ACTIVE condition evaluates to true is executed; the remaining blocks are ignored. If no ACTIVE condition evaluates to true, no statements are executed. An example is:

```
SELECT
{
    ACTIVE (<condition 1>) :
    {
        (* statements for condition 1*)
    }

    ACTIVE (<condition 2>) :
    {
        (* statements for condition 2*)
    }

    ACTIVE (<condition n>) :
    {
        ACTIVE (1)
        (* statements for condition n*)
    }
}
```

Regarding SELECT...ACTIVE statements:

- Only the statements associated with the first condition evaluated to true are executed.
- If no condition evaluates to true, no statements are executed.
- Braces underneath individual ACTIVE statements are required only if multiple statements are assigned to a given condition.

SWITCH...CASE Statements

SWITCH...CASE statements provide selective execution of code blocks evaluated by a single condition. The value of the SWITCH expression is tested against each CASE value (which must be a numeric constant or a string literal). If a match is found, the statements associated with the CASE are executed. All other CASE statements are ignored. If no match is found, the DEFAULT case statements (if any) are executed. The SWITCH expression is evaluated only once. The following is the structure for the SWITCH...CASE statement:

```
SWITCH (<expression>)
{
    CASE <numeric constant or string literal>:
    {
        (* statements for CASE 1 *)
    }
    CASE <numeric constant or string literal>:
    {
        (* statements for CASE 2 *)
    }
    CASE <numeric constant or string literal>:
    {
        (* statements for CASE n; there can be as many cases as necessary *)
    }
    DEFAULT <numeric constant or string literal>:
    {
        (* statements for DEFAULT case *)
    }
}
```

The following rules apply to SWITCH...CASE statements:

- Only the statements associated with the first case that matches the value of the expression are executed.
 - Multiple CASE statements can be stacked within the SWITCH...CASE statement.
 - If the value matches one of the CASE statements, the statements associated with the stack will be executed.
 - If no CASE matches the SWITCH expression, then the statements under the default case (if available) are executed. The default statement must be the last case within the SWITCH...CASE, otherwise the remaining case statements will not execute.
 - All cases must be unique.
 - Braces should be used to bracket the statements in a case. They are required only if variables are declared within the case.
 - The BREAK statement applies to the SWITCH and takes execution to the end of the SWITCH. Unlike C and C++, cases do not fall through to the next case if a break is not used. Because of this, BREAK statements are not required between cases.
- For example:

```
SWITCH (var)
{
    CASE 1:
    {
        (*statements go here*)
        BREAK
    }
    CASE 3:
    {
        (*statements go here*)
        BREAK
    }
    CASE 5:
    {
        (*statements go here*)
        BREAK
    }
    DEFAULT:
    {
        (*statements go here*)
        BREAK
    }
}
```

Loops

FOR Loops

The FOR loop structure allows you to define initialization statements; statements to execute after each pass through the loop and a condition to test after each pass. If the condition evaluates to true, another pass is made. Otherwise, the loop is terminated. The syntax of the FOR loop is as follows:

```
FOR (<INITIAL>; <condition>; <after pass>)
{
    (* loop statements *)
}
```

Parameters:

<INITIAL>	One or more statements that are executed one time before any FOR loop statements are executed. Each statement must be separated with a comma; this is typically a FOR loop index initialization statement.
<condition>	A condition whose value is computed before each pass. If the condition evaluates to TRUE, the FOR loop statements are executed. If the condition evaluates to FALSE, the loop is terminated.
<after pass>	One or more statements that are executed after each pass through the statements. Each statement must be separated with a comma. This is typically a statement that increments the FOR loop index.

The number of loop executions is usually stated at the beginning of the loop, unlike WHILE and LONG_WHILE loops:

```
FOR (COUNT=0 ; COUNT<10 ; COUNT++)
{
    (* loop statements *)
}
```

By defining the loop like this, you clearly see how it is initialized and incremented. No errors appear if you forget to initialize the WHILE loop or counter. The FOR loop helps to insure proper structure.

WHILE Loops

A WHILE statement executes its statement block as long as its associated condition evaluates to true. The condition is evaluated before the first pass through the statements. Therefore, if the conditional expression is never true, the conditional statements are never executed.

The WHILE Loop structure:

```
WHILE (<conditional expression>)
{
    (* conditional statements *)
}
```

Regarding WHILE statements:

- Statements are executed repeatedly while the conditional expression evaluates to true.
- The condition is tested before each pass through the conditional statements.
- There is no timeout period - the NetLinx Controller handles bus updates through a separate execution thread, thereby eliminating this potential problem.

LONG_WHILE statements

A LONG_WHILE differs from a WHILE statement in the way input change notifications are processed during the programming loop. The system checks the input queue for a change notification message before execution of each loop, beginning with the second loop. The message is retrieved if one exists. This message must be processed before another one is retrieved, either at the start of the next loop or the beginning of the next mainline iteration. Otherwise, the message is lost.

The LONG_WHILE Loop structure:

```
LONG_WHILE (<conditional expression>)
{
    (* conditional statements *)
}
```

- DEFINE_EVENT events are still processed even if mainline is in a LONG_WHILE.
- Special care should be taken to avoid spawning concurrent LONG_WHILEs via DEFINE_EVENT code. This can cause excessive drag on system resources.

Conditional and Loop Keywords

NetLinx supports the following Conditional and Loop keywords:

Conditional and Loop Keywords	
BREAK	The BREAK command terminates execution of the current WHILE, LONG_WHILE, or FOR loop and resumes program execution at the first instruction following that loop. BREAK also jumps to the end of a SWITCH statement. <pre>WHILE (<condition>) { // statements IF (<condition>) { BREAK // Go to statement: X = X + 1 } } // Execution continues here after BREAK or // after normal completion of the WHILE loop. X = X + 1</pre>
DEFAULT	Specifies the default case in a SWITCH...CASE statement. See SWITCH...CASE on page 52.
ELSE	If the corresponding IF statement is false, the program will jump to the ELSE section of the IF...ELSE set of statements.

Conditional and Loop Keywords (Cont.)	
FOR	<p>This keyword defines a FOR loop. The looping structure allows you to define initialization statements, statements to execute after each pass through the loop and a condition to test after each pass. If the condition evaluates to true, another pass is made; otherwise the loop is terminated.</p> <pre>FOR (<initial>; <condition>; <after pass>) { (* for loop statements *) }</pre>
IF	<p>This keyword defines an IF statement; the IF statement provides conditional branching of program execution.</p> <pre>IF (<expression>) { // statements } ELSE IF (<expression>) { // statements } ELSE { // statements }</pre> <p>The ELSE IF and ELSE statements are optional. The braces delimiting the statements, associated with each condition, are required only if there is more than one statement. For example, the following syntax is correct:</p> <pre>IF (X > 0) X = X - 1</pre>
IF...ELSE	<p>The IF statement provides a structure for conditional branching of program execution. If a condition evaluates to true, the statement(s) associated with it are executed; otherwise statements are not executed.</p> <p>Example:</p> <pre>IF (<conditional expression 1>) { (* statements for condition 1 *) } ELSE IF (<conditional expression 2>) { (* statements for condition 2 *) } ELSE { (* statements for all other conditions *) }</pre> <p>Regarding IF statements:</p> <ul style="list-style-type: none"> • ELSE IF and ELSE are optional • Braces are only required if multiple statements are assigned to a given condition but are generally recommended in all cases • IF statements may be nested to any number of levels
INCLUDE	<p>This keyword allows you to include programming instructions from an external file and have those instructions inserted at any point in the program.</p> <pre>INCLUDE '<filename>'</pre> <p>The parameter filename can be any valid (long) filename. If the file extension is omitted, "AXI" is assumed. An INCLUDE statement can appear anywhere in a program.</p> <p>NOTE: <i>There is no difference in functionality between the INCLUDE reserved identifier and the #INCLUDE compiler directive. INCLUDE is supported for backward-compatibility to Access (see #INCLUDE on page 29).</i></p>
SELECT...ACTIVE	<p>This keyword statement provides a programming construct for selective execution of code blocks based on the evaluation of a series of conditions.</p>
SWITCH...CASE	<p>This keyword statement provides a programming construct for selective execution of code blocks based on the evaluation of a single condition.</p> <pre>SWITCH (var) { CASE 1: { IF (Var2=1) { BREAK // IF Var2=1 STOP EXECUTION } (statements go here if Var2 < > 1) } CASE 3: { (statements go here) } CASE 5: { (statements go here) } DEFAULT: { (statements go here) } }</pre>

Conditional and Loop Keywords (Cont.)	
WHILE	<p>This keyword executes its statement block as long as its associated condition evaluates to true. The condition is evaluated before the first pass through the statements. Therefore, if the conditional expression is never true the conditional statements will never be executed.</p> <pre> WHILE (<conditional expression>) { (* conditional statements *) } </pre>
MEDIUM_WHILE	This keyword is obsolete in the new NetLinx system. The compiler will treat it as a WHILE keyword.
LONG_WHILE	<p>This keyword is the same as a WHILE statement except that input messages are retrieved after each pass to allow the LONG_WHILE statements to process the input.</p> <pre> LONG_WHILE (<conditional expression>) {(* conditional statements *)} </pre> <p>See the <i>LONG_WHILE statements</i> section on page 51 for more information.</p>
FALSE	This keyword is a CHAR constant containing the value 0. While NetLinx does not support a BOOLEAN data type, zero is considered <i>false</i> conditional expressions.
TRUE	This keyword is a CHAR constant and contains the value 1. While NetLinx does not support a BOOLEAN data type, a non-zero value is considered <i>true</i> for conditional expressions.

Data Event Keywords

NetLinX supports the following Data Event keywords:

Data Event Keywords	
AWAKE	This keyword defines a section in a DATA event handler for processing AWAKE notifications. This event is triggered when the master recognizes that a device on the bus has exited STANDBY state. Once the device is AWAKE, communication to the device from the master can resume.
COMMAND	This keyword defines a section in a DATA event handler for processing SEND_COMMAND instructions.
HOLD	This keyword defines a section in a BUTTON event handler for processing HOLD events.
ONERROR	This keyword defines a section in a DATA event handler for processing ONERROR notifications. Any error triggers an ONERROR event.
OFFLINE	This keyword defines a section in a DATA event handler for processing OFFLINE notifications. This is one of the important aspects of the DATA_EVENT that is triggered when the master recognizes that a device has been dropped off the bus.
ONLINE	This keyword defines a section in a DATA event handler for processing ONLINE notifications. This is one aspect of DATA_EVENT that is triggered when the master recognizes that a device has been added to the bus. In NetLinX, every device triggers an ONLINE event when the master is reset. This ensures that the device is initialized on startup and that the device is initialized any time the device comes online.
REPEAT	This keyword may be used with the HOLD keyword to specify that the (hold button) event should be allowed to repeat. See the <i>Event Handler Keywords</i> on page 74 for more information.
STANDBY	This keyword defines a section in a DATA event handler for processing STANDBY notifications. This event is triggered when the master recognizes that a device on the bus has gone into a STANDBY state. While in standby state, all communication to the device from the master is dropped.

Data Types and Conversion Keywords

Overview

NetLinx supports integers up to 32-bits and signed values to allow positive and negative values.

Intrinsic Data Types

The following Data Types are intrinsic to the NetLinx language:

Intrinsic Data Types					
Keyword	Data Type	Sign	Size	Range	
CHAR	Byte	Unsigned	8-bit	0	to 255
WIDECHAR	Integer	Unsigned	16-bit	0	to 65,535
INTEGER	Integer	Unsigned	16-bit	0	to 65,535
SINTEGER	Integer	Signed	16-bit	-32,768	to 32,767
LONG	Long Integer	Unsigned	32-bit	0	to 4,294,967,295
SLONG	Long Integer	Signed	32-bit	-2,147,483,648	to 2,147,483,647
FLOAT	Floating Point	Signed	32-bit	-3.40282346e+38	to 3.40282346e+38
DOUBLE	Double Precision Floating Point	Signed	64-bit	-1.79769313e+308	to 1.79769313e+308

Intrinsic Data Type Keywords

Intrinsic Data Type Keywords	
CHAR	<p>CHAR is used to store single-byte values and character strings. This data type is used with ANSI character strings.</p> <ul style="list-style-type: none"> Data Type: Byte Sign: Unsigned Size: 8-bit Range: 0 - 255 Sample of Stored Values: 'a', 145, \$FE, 'The quick gray fox'
WIDECHAR	<p>WIDECHAR is an intrinsic data type representing a 16-bit unsigned integer. This data type is intended for use with Unicode fonts that use 16-bit character codes (and most Far-eastern fonts).</p> <ul style="list-style-type: none"> Data Type: Integer Sign: Unsigned Size: 16-bit Range: 0 to 65,535 Sample of Stored Values: "'OFF',500"
INTEGER	<p>INTEGER is the default variable value to store values up to and including 65535. This is the default data type if a non-array variable is declared without a data type specified.</p> <ul style="list-style-type: none"> Data Type: Integer Sign: Unsigned Size: 16-bit Range: 0 to 65,535 Sample of Stored Values: 512, 32468, 12
SINTEGER	<p>SINTEGER is used to store signed integer values both greater than and less than zero.</p> <ul style="list-style-type: none"> Data Type: Integer Sign: Signed Size: 16-bit Range: -32,768 to 32,767 Sample of Stored Values: 24, -24, 568, -568
LONG	<p>LONG defines an intrinsic data type representing a 32-bit unsigned value. It is used to store large integer values greater than 65535.</p> <ul style="list-style-type: none"> Data Type: Long Integer Sign: Unsigned Size: 32-bit Range: 0 - 4,294,967,295 Sample of Stored Values: 1000000, 2000046
SLONG	<p>SLONG defines an intrinsic data type representing a 32-bit signed integer. It is used to store signed large integer values less than -32767 and greater than 32767.</p> <ul style="list-style-type: none"> Data Type: Long Integer Sign: Signed Size: 32-bit Range: -2,147,483,648 to 2,147,483,647 Sample of Stored Values: -1000000, 1000000, -2000000, 2000000

Intrinsic Data Type Keywords (Cont.)	
FLOAT	<p>FLOAT defines an intrinsic data type representing a 64-bit signed floating-point value. It is used to store small real numbers with 5 digits of precision.</p> <ul style="list-style-type: none"> • Data Type: Floating Point • Sign: Signed • Size: 64-bit • Range: -3.40282346e+38 to 3.40282346e+38 • Sample of Stored Values: 1.2345, 123.4512345e5, -16.3231415
DOUBLE	<p>DOUBLE defines an intrinsic data type representing a 64-bit (double precision) signed floating-point value. It is used to store large real numbers with 15 digits of precision.</p> <ul style="list-style-type: none"> • Data Type: Double Precision Floating Point • Sign: Signed • Size: 64-bit • Range: -1.79769313e+308 to 1.79769313e+308 • Sample of Stored Values: 1.23456789012345, 12,345,678.9012545, 3.14159265358979, -0.048512934

Structured Data Types

Structured Data Type Keywords	
DEV	<p>A data type (structure) used to represent a specific device, port, and system. In NetLinx, the DEV structure is the actual (internal) representation of a NetLinx device.</p> <p>Example:</p> <pre>STRUCTURE DEV { INTEGER Number INTEGER Port INTEGER System }</pre> <p>NOTE: See the <i>Device Arrays</i> section on page 23 for more information.</p>
DEVCHAN	<p>DEVCHAN defines a data type (structure) containing fields used to represent a specific device number, port, system, and channel.</p> <p>Example:</p> <pre>STRUCTURE DEVCHAN { DEV Device INTEGER Channel }</pre> <p>NOTE: See the <i>Device-Channels and Device-Channel Arrays</i> section on page 24 for more information.</p>
DEVLEV	<p>A data type (structure) containing fields used to represent a specific device number, port, system and level. This structure is used to implement an array DEVLEV[].</p> <p>Example:</p> <pre>STRUCTURE DEVLEV { DEV Device INTEGER Level }</pre> <p>See the <i>Device-Level Arrays</i> section on page 24 for more information.</p>

Combining and Uncombining Device/Channel Sets

Combining DEVCHAN sets is unique to NetLinx. The format for COMBINE_CHANNELS and UNCOMBINE_CHANNELS is:

```
SLONG COMBINE_CHANNELS (<virtual DEVCHAN[]>, <DEVCHAN1[]>, <DEVCHAN2[]>...)
SLONG UNCOMBINE_CHANNELS (<virtual DEVCHAN[]>)
```

To explain the concept of combining DEVCHAN sets, it is necessary to understand how the DEVCHAN sets are arranged. Rather than the DEVCHAN set being a set of like functions, such as a set of volume mute buttons across different devices, the DEVCHAN set should be a group of different functions on the same device, such as 5 lighting presets on an AXU-MSP16. For example:

```
DEVCHAN dcMSP1 =
{{MSP1, PRESET1}, {MSP1, PRESET2}, {MSP1, PRESET3}, {MSP1, PRESET4}, {MSP1, PRESET5}}
DEVCHAN dcMSP2 =
{{MSP2, PRESET1}, {MSP2, PRESET2}, {MSP2, PRESET3}, {MSP2, PRESET4}, {MSP2, PRESET5}}
DEVCHAN dcMSP3 =
{{MSP3, PRESET1}, {MSP3, PRESET2}, {MSP3, PRESET3}, {MSP3, PRESET4}, {MSP3, PRESET5}}
```

Similar to COMBINE_DEVICES and COMBINE_LEVELS, the first DEVCHAN set in a COMBINE_CHANNEL function needs to be referenced to a Virtual Device, as shown below:

```
DEVCHAN dcVDEV =
{{VDEV, PRESET1}, {VDEV, PRESET2}, {VDEV, PRESET3}, {VDEV, PRESET4}, {VDEV, PRESET5}}
```

All of the DEVCHAN sets in the COMBINE_CHANNELS function must have the same number of array elements. The actual COMBINE_CHANNELS statement is:

```
COMBINE_CHANNELS (dcVDEV, dcMSP1, dcMSP2, dcMSP3)
```

The actual element positions of the DEVCHAN arrays are combined within the program. In essence, all of the PRESET1 channels are handled through [VDEV,PRESET1] defined as dcVDEV[1].

NOTE: When using `COMBINE_XXXX` and `UNCOMBINE_XXXX` functions dynamically based upon a button event, the combining and uncombining must be done on the release of the button (the active event must be complete before a `COMBINE_XXXX` or `UNCOMBINE_XXXX` function is invoked).

Type Conversion

Although explicit type casting is not supported in NetLinx, the compiler is forced to do type conversion in situations where an arithmetic assignment or other operation is defined with constants and/or variables having mixed data types. Type conversions will occur under the following circumstances:

- A value of one type is assigned to a variable of another type.
- A value passed as a parameter to a subroutine does not match the declared parameter type.
- The value returned by a subroutine does not match the declared return type.

Type Conversion Rules

- If the expression contains a 32 or 64-bit floating-point variable or constant, all variables and constants in the expression are converted to 64-bit floating point before resolving.
- If the expression contains only whole number value variables and constants, all variables and constants in the expression are converted to 32-bit integers before resolving.
- If type conversion is required for an assignment or as a result of a parameter or return type mismatch, the value is converted to fit the type of the target variable. This may involve truncating the high order bytes(s) when converting to a smaller size variable, or sign conversion when converting signed values to unsigned or vice versa.

Conversion Keywords

NetLinx supports the following Conversion keywords:

Conversion Keywords	
ATOI	<p>ATOI converts a character representation of a number to a signed 32-bit integer. It recognizes a character representation of a value that would be within the ranges of the data types: INTEGER, SINTEGER, and SLONG.</p> <p>Syntax: <code>SLONG ATOI (CHAR STRING[])</code></p> <p>Parameters:</p> <ul style="list-style-type: none"> • STRING - string containing the character representation of the integer. Valid input characters are "0" through "9" and the sign designators "+" and "-". If no valid characters are found, zero is returned as a result. <p>Result:</p> <ul style="list-style-type: none"> • A 32-bit integer representing the converted string. • Any non-numeric characters in the string are ignored. • ATOI returns the value representing the first complete set of characters that represents an integer. <p>NOTE: While you can pass in larger values, ATOI will truncate any value outside the range -2147483648 to 2147483647 to the value -2147483648 (if negative) or 2147483647 (if positive).</p> <p>Example: <code>Vol = ATOI('Volume=100%') // Vol = 100</code> <code>Num = ATOI('-3758') // Num = -3758</code></p>
ATOF	<p>Converts a character representation of a number to a 64-bit floating-point value. ATOF recognizes a character representation of a value that would be within the ranges of <i>all</i> intrinsic data types, with the exception of CHAR.</p> <p>Syntax: <code>FLOAT ATOF (CHAR STRING[])</code></p> <p>Parameters:</p> <ul style="list-style-type: none"> • STRING: An input string containing the character representation of the floating-point number. Valid input characters are "0" through "9", ".", the sign designators "+" and "-", and the exponent ("e" or "E"). If no valid characters are found, zero is returned as a result. <p>Result:</p> <ul style="list-style-type: none"> • 64-bit floating-point number representing the converted string. • Any non-numeric characters in the string are ignored. • ATOF returns the value representing the first complete set of characters that represents a floating-point value. <p>NOTE: When assigning the result to a <code>DOUBLE</code> the effective range is $\pm 2.22507E-1$ to $\pm 1.79769E+308$.</p> <p>Example: <code>Num = ATOF('-1.25e-3') // Num = -0.00125</code></p>

Conversion Keywords (Cont.)	
ATOL	<p>ATOL converts a character representation of a number to a signed 32-bit integer. ATOL recognizes a character representation of a value that would be within the ranges of the data types: INTEGER, SINTEGER, and SLONG.</p> <p>Syntax: <code>SLONG ATOL (CHAR STRING[])</code></p> <p>Parameters:</p> <ul style="list-style-type: none"> • <code>STRING</code> - string containing the character representation of the integer. Valid input characters are "0" through "9" and the sign designators "+" and "-". If no valid characters are found, zero is returned as a result. <p>Result:</p> <ul style="list-style-type: none"> • A 32-bit integer representing the converted string. • Any non-numeric characters in the string are ignored. • ATOL returns the value representing the first complete set of characters that represents an integer. <p>NOTE: <i>While you can pass in larger values, ATOI will truncate any value outside the range -2147483648 to 2147483647 to the value -2147483648 (if negative) or 2147483647 (if positive).</i></p> <p>Example: <code>Vol = ATOL('Volume=100%') // Vol = 100</code> <code>Num = ATOL('-3758') // Num = -3758</code></p>
CH_TO_WC	<p>This keyword converts a CHAR array to a WIDECHAR array.</p> <p><code>WIDECHAR[] CH_TO_WC (CHAR STRING[])</code></p> <p>Parameters:</p> <ul style="list-style-type: none"> • <code>STRING</code> - a character string to be converted. <p>Result:</p> <ul style="list-style-type: none"> • A WIDECHAR array containing the values from the CHAR array. <p><code>WIDECHAR wcData[] = CH_TO_WC('ASCII')</code></p>
FTOA	<p>This function converts a 64-bit floating-point value to an ASCII string containing the decimal representation of the number.</p> <p><code>CHAR[] FTOA (DOUBLE Num)</code></p> <p>Parameters:</p> <ul style="list-style-type: none"> • <code>Num</code>: 64-bit Floating-point number to convert to a decimal string. <p>Result:</p> <ul style="list-style-type: none"> • Character string that contains the decimal representation of the specified floating point number, rounded to 6 digits of precision. • The character representation uses exponents as necessary, according to the following rule: For $0.0001 \leq n < 1000000$, FTOA returns the result in non-exponential form; otherwise, it returns the result in exponential form. <p>Examples: <code>n=1000000 returns '1E+06'</code> <code>n=1234567 returns '1.23457E+06'</code> <code>n=-0.001 returns '-0.001'</code> <code>n=0.00045 returns '0.00045'</code> <code>n=0.000045 returns '4.5E-05'</code> <code>n=123.45678 returns '123.457'</code></p>
HEXTOI	<p>This function converts an ASCII string containing the hexadecimal representation of a number to an unsigned 32-bit integer.</p> <p><code>LONG HEXTOI (CHAR STRING[])</code></p> <p>Parameters:</p> <ul style="list-style-type: none"> • <code>STRING</code>: Hexadecimal formatted string to be converted to an integer. <p>Result:</p> <ul style="list-style-type: none"> • 32-bit unsigned integer representing the converted string. • Any non-hexadecimal characters in the string are ignored. • HEXTOI returns a value representing the first complete set of characters that represents an integer. • Valid characters are "0" through "9", "A" through "F" and "a" through "f". • If no valid characters are found, zero is returned as a result. <p>Example: <code>Num = HEXTOI('126EC') // Num = 75500</code></p>
ITOA	<p>This function converts a 32-bit signed integer to a decimal ASCII string.</p> <p><code>CHAR[] ITOA (LONG Num)</code></p> <p>Parameters:</p> <ul style="list-style-type: none"> • <code>Num</code>: The 32-bit signed integer to convert to a decimal string. <p>Result: A character string that contains the decimal representation of the specified integer.</p> <p><code>STRING = ITOA(501) // STRING = '501'</code></p>

Conversion Keywords (Cont.)									
FORMAT	<p>Provides a mechanism similar to 'C's printf statement for formatting the display of numbers. This function is similar to ITOA but is infinitely more powerful.</p> <pre>CHAR[] FORMAT (CHAR FormatLine[], CHAR Value) CHAR[] FORMAT (CHAR FormatLine[], WIDECHAR Value) CHAR[] FORMAT (CHAR FormatLine[], INTEGER Value) CHAR[] FORMAT (CHAR FormatLine[], SINTEGER Value) CHAR[] FORMAT (CHAR FormatLine[], LONG Value) CHAR[] FORMAT (CHAR FormatLine[], SLONG Value) CHAR[] FORMAT (CHAR FormatLine[], FLOAT Value) CHAR[] FORMAT (CHAR FormatLine[], DOUBLE Value)</pre> <p>Parameters:</p> <ul style="list-style-type: none"> FormatLine: A formatted string of text that defines how the (return) string should be formatted. The format string contains plain characters and a conversion specification. Plain characters are copied, as is, directly. Conversion characters conform to the following format: <pre>%[flags][width][.prec]type</pre> <ul style="list-style-type: none"> flags: Output justification, numeric signs, decimal points, trailing zeros, octal and hex prefixes. By default, output is right justified. Use a '-' to left justify as in %-5d. -: Causes left justification, padding with blanks 0: Zeros are used to pad instead of spaces if a field length is given. +: Output always begins with + or -. Blank: Positive values begin with a blank. width: Minimum number of characters to print. If the output would be less than this width, it is padded with spaces to be width characters wide. If the output is larger than width the entire output is provided (i.e. it is not truncated). .prec: Maximum number of characters to print or number of digits to the right of the decimal point for a float or double type. type: Conversion type: <ul style="list-style-type: none"> c: Value is treated as an integer, and presented as the character with that ASCII value. d: Value is treated as a signed integer, and presented as a decimal number. f: Value is treated as a double, and presented as a floating-point number. o: Value is treated as a signed integer, and presented as an octal number. u: Unsigned integer. x: Value is treated as an integer and presented as a hexadecimal number (with lowercase letters). X: Value is treated as an integer and presented as a hexadecimal number (with uppercase letters). %: A literal percent character. Value: The value to be converted to a string. The result is a formatted text string. <pre>fTemperature = 98.652 STR = FORMAT('The current temperature is %3.2f', fTemperature) // Displays "The current temperature is 98.65"</pre> <p>The table below shows some examples of the output of FORMAT for several different format lines and values:</p> <table border="1"> <thead> <tr> <th>FORMAT Statement</th> <th>Result of FORMAT function</th> </tr> </thead> <tbody> <tr> <td>FORMAT('%-5.2f', 123.234)</td> <td>'123.23'</td> </tr> <tr> <td>FORMAT('%5.2f', 3.234)</td> <td>'3.23'</td> </tr> <tr> <td>FORMAT('%+4d', 6)</td> <td>'+6'</td> </tr> </tbody> </table> <p>The result is a formatted text string.</p> <pre>fTemperature = 98.652 STR = FORMAT('The current temperature is %3.2f', fTemperature) // Displays "The current temperature is 98.65"</pre> 	FORMAT Statement	Result of FORMAT function	FORMAT('%-5.2f', 123.234)	'123.23'	FORMAT('%5.2f', 3.234)	'3.23'	FORMAT('%+4d', 6)	'+6'
FORMAT Statement	Result of FORMAT function								
FORMAT('%-5.2f', 123.234)	'123.23'								
FORMAT('%5.2f', 3.234)	'3.23'								
FORMAT('%+4d', 6)	'+6'								
ITOHX	<p>This function converts a 32-bit unsigned integer to an ASCII string containing the hexadecimal representation of the number.</p> <pre>CHAR[] ITOHX (LONG Num)</pre> <p>Parameters:</p> <ul style="list-style-type: none"> Num: The 32-bit unsigned integer to convert to a hexadecimal string. <p>Result: A character string that contains the hexadecimal representation of the specified integer.</p> <pre>STRING = ITOHX(1000) // STRING = '3E8'</pre>								
RAW_BE	<p>This routine takes an intrinsic variable and converts it into a Character Array in Big Endian Format representing the variable.</p> <pre>CHAR[] RAW_BE(IntrinsicVariable)</pre>								
RAW_LE	<p>This routine takes an intrinsic variable and converts it into a Character Array in Little Endian Format representing the variable.</p> <pre>CHAR[] RAW_LE(IntrinsicVariable)</pre>								

NOTE: NetLinx also provides a set of Encode & Decode keywords. See Encode / Decode Keywords on page 70 for details.

DEFINE Keywords

Overview

NetLinx has two methods for creating subroutines: `DEFINE_CALL` and `DEFINE_FUNCTION`.

DEFINE_CALL

`DEFINE_CALL` is intended to run segments of code that are repeated throughout the program, but don't require a return value. For example, this `DEFINE_CALL` creates a macro to lower a screen, turn on the projector, and set the lights to Preset 1. The subroutine executes three commands and no values are returned to the program.

```
DEFINE_CALL 'PRESENTATION MACRO'
{
    SYSTEM_CALL [1] 'SCREEN1' (0, 0, 1, 0, SCREEN, 1, 2, 3, 0)
    SEND_STRING VPROJ, "'PON', $0D, $0A"
    SEND_STRING RADIA, "'1B', $0D"
}
```

The NetLinx compiler passes all variables by reference. This means that the variable the subroutine operates on is the same variable the caller passed. Any change made to the variable, passed as a calling parameter, updates the variable's value from the caller's perspective. You can take advantage of this pass by reference feature by returning an updated value through a calling parameter rather than as the return value. Constants, on the other hand, are passed by value. When this happens, a copy of the parameter is delivered to the subroutine. Any change made to the variable representing the constant is lost once the function or subroutine is lost. To specify an array as a function or subroutine parameter, one set of brackets for each array dimension must follow the variable name, as shown in the following example:

```
DEFINE_CALL 'READ INPUT' (CHAR BUFFER[ ][ ])
{
    (* body of the subroutine *)
}
```

The parameter `BUFFER` is declared to be a two-dimensional array by including two sets of brackets after the name. For compatibility with existing programs, the array dimensions may be specified inside the brackets. These dimensions, however, are not required and are ignored by the compiler. The NetLinx Interpreter will do bounds checking on the array and generate a run-time error if the array bounds are exceeded.

NOTE: *Subroutines must be defined before they can be used. For this reason, `DEFINE_CALL`s should appear before the `DEFINE_START`, `DEFINE_EVENT`, and `DEFINE_PROGRAM` sections.*

DEFINE_FUNCTION

`DEFINE_FUNCTION` provides a way to return a value to a statement. It has the same functionality as a `DEFINE_CALL`. The `DEFINE_FUNCTION` is used in-line in a statement, where a `DEFINE_CALL` must be used as a standalone statement. The basic structure is:

```
DEFINE_FUNCTION [<return type>]<name>[(<param1>, <param2>, ... <paramN>)]
{
    (* statements *)
}
```

The following `DEFINE_FUNCTION` creates a subroutine to cube a number and returns a `LONG` integer value:

```
DEFINE_FUNCTION LONG CUBEIT (LONG VALUE)
{
    STACK_VAR RESULT
    RESULT = VALUE * VALUE * VALUE
    RETURN RESULT
}

DEFINE_PROGRAM
PUSH[TP1, 1]
{
    CUBED_VAL = CUBEIT ( 3 )
    (* CUBED_VAL = 27 *)
}
```

DEFINE_CONSTANT

The standard format for DEFINE_CONSTANT is:

```
<constant name> = <constant expression>
```

NetLinx allows variables to be defined as constants in the DEFINE_VARIABLE section of the program or module, and in the LOCAL_VAR section of a DEFINE_CALL or a DEFINE_FUNCTION. The scope of the constant extends throughout the module in which it is defined. If the DEFINE_CONSTANT section appears in the main program or in an include file, the constant's scope extends globally throughout the program. DEFINE_CONSTANT accepts data in the following formats:

DEFINE_CONSTANT Data Formats		
Type	Format	Example
Decimal Integer	O000	1500
Hexadecimal Integer	\$000	\$DE60
Floating Point	000.0	924.5
Exponential Notation	0.0e0	.5e-12
Character	'c' or <char code>	'R' or 255
String Literal	'ssss'	'Reverse'

DEFINE Keywords

DEFINE Keywords	
DEFINE_CALL	<p>This keyword defines the implementation of a NetLinx subroutine.</p> <pre>DEFINE_CALL '<name>' [(P1,P2,...)] { // body of subroutine }</pre> <p>The subroutine name cannot be a previously defined device name, constant, or variable, or a name assigned to a buffer or a wait statement. DEFINE_CALL names are case sensitive and may contain spaces. Subroutines must be defined before they can be used. For this reason, DEFINE_CALLs should appear before the DEFINE_START, DEFINE_EVENT, and DEFINE_PROGRAM sections.</p>
DEFINE_COMBINE	<p>This keyword defines the combination of functionally identical devices, such as identically programmed touch panels. When the program references one of these devices, all other combined devices are also referenced. The devices in a given combine must be enclosed in parentheses. The first device in the list (the primary device) must be a virtual device.</p> <pre>DEFINE_COMBINE (VDevice, Panel1, Panel2, Panel3)</pre> <p>The example below uses a device array (DEV[]) instead of specifying the individual devices (Panel1, Panel2, and Panel3).</p> <p>Any input events for any device in the array will appear to the program as coming from the virtual device. Output changes directed to the virtual device or any device in the set is sent to all devices in the array.</p> <pre>DEFINE_COMBINE (VDevice, DEV[])</pre> <p>See the <i>Combine & Uncombine Keywords</i> on page 40 for more information on virtual devices and device arrays.</p>
DEFINE_CONNECT_LEVEL	<p>This keyword defines level connections. A single connection is defined by listing the device-level pairs inside parentheses. The first level in the list (the primary level) must be a virtual level (a level on a virtual device). A virtual level does not actually exist but merely represents one or more levels on physical devices. The example below combines the levels [Device1, Level1] and [Device2, Level2].</p> <pre>(VDevice, Level1, Device1, Level1, Device2, Level1)</pre> <p>The next example combines all levels in the device-level array.</p> <p>Changes to any level listed in the connection will automatically be reflected in the other levels so that all level values are the same.</p> <pre>DEFINE_CONNECT_LEVEL (VDevLev, MyDL[])</pre> <p>By specifying a virtual level as the primary level, NetLinx code targets the virtual level but operates on each physical level. Since the primary level is virtual, the primary device (a virtual device) cannot be taken off-line or removed from the system.</p>
DEFINE_CONSTANT	<p>This keyword defines program constants; the value of a constant cannot be changed within the program.</p> <pre>DEFINE_CONSTANT PLAY = 1 STOP = 2 STRING='HELLO'</pre> <p>Refer to the <i>DEFINE_CONSTANT</i> section on page 61 for more information.</p>
DEFINE_DEVICE	<p>This keyword defines the devices referenced in the program.</p> <pre>DEFINE_DEVICE TP1 = 128:1:0// device number = 128, port = 1, system = 0 TP2 = 129:1:0// device number = 129, port = 1, system = 0 TP3 = 130:1:0// device number = 130, port = 1, system = 0 VCR1 = 10:1:0 // device number = 10, port = 1, system = 0 VCR2 = 11:1:0 // device number = 11, port = 1, system = 0</pre> <p>Devices can be specified by a single device number such as "TP = 128" or as a fully-qualified device specification such as "TP = 128:1:0"</p>

DEFINE Keywords (Cont.)	
DEFINE_EVENT	<p>This keyword provides the basis for the construction of the event table, which is where event-handling code is placed. When NetLinx receives an incoming event, the event table is searched for a handler for that event.</p> <p>A handler is a block of code that performs the necessary processing for an event notification received from a given device (and possibly associated with a particular channel). See the <i>Event Handler Keywords</i> on page 74 for more information.</p>
DEFINE_FUNCTION	<p>This keyword defines the implementation of a NetLinx function.</p> <pre>DEFINE_FUNCTION [<return type>] FnName(P1,P2,...) { // function statements }</pre> <p>The return type is optional and can be any intrinsic data type or array of intrinsic types that NetLinx supports except a structure or an array of structures. The function name must not be a previously defined constant or variable or a name assigned to a buffer, a wait, DEFINE_CALL, or Function. Function names are not case sensitive. See the <i>DEFINE_FUNCTION</i> section on page 60 for more information.</p>
DEFINE_LATCHING	<p>This keyword section is where latching channels and variables are defined. A latching channel is one that changes its state once per activation. If a latching channel is activated by a TO keyword, it changes its state. When the TO is stopped by releasing the button that started it, the channel does not go back to its previous state. The status of a latching channel (that is not part of a mutually exclusive group) will always reflect the on/off state of the channel.</p> <p>In the following example, the device-channel [RELAY, SYSTEM_POWER] is defined as latching. The next statement uses the double periods (..) to define a range of VCR channels as latching. In the last statement, the variable VAR1 is defined as latching.</p> <pre>DEFINE_LATCHING [RELAY, SYSTEM_POWER] [VCR, PLAY]..[VCR, REWIND] VAR1</pre>
DEFINE_MODULE	<p>This keyword declares a module that will be used by either the main program or another module. It is the counterpart to the MODULE_NAME entry that appears as part of the implementation of the module.</p> <pre>DEFINE_MODULE '<module name>' InstanceName (<parameter list>)</pre> <p>Parameters:</p> <ul style="list-style-type: none"> • <module name>: The name of the module as specified in the MODULE_NAME statement in the module implementation file. • InstanceName: The name to assign to the instance of the module. • <parameter list>: The list of parameters available to the module.
DEFINE_MUTUALLY_EXCLUSIVE	<p>When a channel is turned on in a mutually exclusive set, it activates its physical output as long as the button is pressed. When the button is released, the physical output stops. Even after the physical output stops, the feedback still indicates the channel is on until another channel in the mutually exclusive set is activated. The status remains on to indicate which channel in the set was activated last (last button pushed feedback). When a channel or variable in a mutually exclusive set is activated, all other members of the set are turned off beforehand (break before make logic). Members of a mutually exclusive set are placed in parentheses underneath the DEFINE_MUTUALLY_EXCLUSIVE keyword. The double period (..) specifies a range of channels on the particular device to be defined as mutually exclusive.</p> <pre>DEFINE_MUTUALLY_EXCLUSIVE ([RELAY, SCREEN_UP], [RELAY, SCREEN_DOWN]) DEFINE_TOGGLING [RELAY, SCREEN_UP] [RELAY, SCREEN_DOWN]</pre> <p>The last entry specifies a set of mutually exclusive variables - VCR_SELECT, CD_SELECT, and CASS_SELECT. If any one of the three variables is turned on (e.g., "ON [VCR_SELECT]") the other two are turned off.</p> <p>If a channel is defined to be both mutually exclusive and latching, it has the same behavior described above except that the channel stays on even after the button that activated it is released.</p> <p>Theoretically, a channel in a mutually exclusive latching set cannot be turned off without activating another channel in the same set. In NetLinx, you can bypass this rule by using TOTAL_OFF. The TOTAL_OFF function turns a channel or variable off. Unlike OFF, TOTAL_OFF turns off the status of a channel or variable that is in a mutually exclusive set.</p>
DEFINE_PROGRAM	<p>This keyword defines the mainline code, which is executed continuously to process input and to provide device feedback.</p> <p>See the <i>Mainline</i> on page 17 for more information. Also refer to the <i>Understanding When DEFINE_PROGRAM Runs</i> section on page 18 for details on using DEFINE_PROGRAM effectively.</p>
DEFINE_START	<p>This keyword contains instructions that are executed once at program startup; in other words, at power-up or after a system reset.</p>
DEFINE_TOGGLING	<p>When a channel is defined as mutually exclusive and latching, there is no way to turn off the channel without activating another. Mutually exclusive toggling allows a channel to be turned on or off by successive presses of the same button, like a normal latching channel. The channel is still affected by its mutually exclusive characteristics; if the channel is on, it can be turned off by activating another channel in the set. The status of a mutually exclusive toggling button operates the same way as a mutually exclusive latching button.</p> <p>To make a channel toggling, it must be defined as both mutually exclusive and toggling, as shown below:</p> <pre>DEFINE_MUTUALLY_EXCLUSIVE([RELAY, SCREEN_UP], [RELAY, SCREEN_DOWN]) DEFINE_TOGGLING[RELAY, SCREEN_UP] [RELAY, SCREEN_DOWN]</pre>

DEFINE Keywords (Cont.)	
DEFINE_TYPE	<p>This keyword section defines custom data types such as structures and arrays. An example DEFINE_TYPE section is shown below.</p> <pre>DEFINE_TYPE STRUCTURE MyStruct { LONG Num CHAR Name[30] }</pre> <p>See the <i>Structure Keywords</i> on page 130 for a discussion of structures.</p>
DEFINE_VARIABLE	<p>This keyword declares global variables. Any variable defined in this section is static (its value is maintained throughout the duration of program execution) with module scope (it is accessible from any instruction in the current module).</p> <pre>DEFINE_VARIABLE INTEGER INT1 FLOAT FP1 VOLATILE INTEGER BIGARRAY[1000][1000]</pre> <p>NOTE: 1000 marks the limit of the string.</p> <p>See the <i>Variables - Overview</i> on page 9 for more information.</p>
PROGRAM_NAME	<p>This keyword declares the program name. It must appear on the first line of the program and cannot appear more than once in any single program or include file.</p> <pre>PROGRAM_NAME = '<program name>'</pre>
RETURN	<p>This keyword is used in a DEFINE_FUNCTION or DEFINE_CALL subroutine to prematurely terminate execution and/or to return a value to the caller. Only DEFINE_FUNCTION functions can return values using the RETURN statement.</p> <p>The syntax of the RETURN statement is either:</p> <pre>RETURN // DEFINE_CALL or function with no return value or RETURN Value // function with return value</pre> <p>Upon execution of the RETURN statement, program control is immediately returned to the caller. If the function containing the RETURN statement has a declared return type, the parameter Value must be included and match the specified type. If the function has no declared return type, the parameter Value must be omitted.</p>

DEFINE_MUTUALLY_EXCLUSIVE and Variables

Symptom: If you have a set of variables that are mutually exclusive and you set one of the variables to a non-zero value by assignment, e.g. Var1 = 1 or the Studio Debug window, then the other variables in the set stay "on" i.e. non-zero.

```
DEFINE_VARIABLE
INTEGER var[4]
INTEGER x
DEFINE_MUTUALLY_EXCLUSIVE
(var[1],var[2],var[3],var[4])
DEFINE_PROGRAM
WAIT 20
{
x++; IF (x > 4) x = 1;
var[x] = x // This will not invoke the mutually exclusive magic
}
```

In the NetLinx code example above, all elements of var will eventually be non-zero.

Cause: This has always worked this way, even in Aaccess.

Resolution: Use ON to set variables if they are members of a mutually exclusive set:

```
DEFINE_VARIABLE
INTEGER var[4]
INTEGER x
DEFINE_MUTUALLY_EXCLUSIVE
(var[1],var[2],var[3],var[4])
DEFINE_PROGRAM
WAIT 20
{
x++; IF (x > 4) x = 1;
ON[var[x]] // This will work as expected - only one element of var will have a value of 1 at any time
}
```

This issue does not occur with DEVCHAN's. Using ON or assigning them a non-zero value will work as expected:

```
DEFINE_DEVICE
dvRelay = 305:1:0
DEFINE_VARIABLE
INTEGER x
DEFINE_MUTUALLY_EXCLUSIVE
([dvRelay,1]..[dvRelay,4])
([dvRelay,5]..[dvRelay,8])
DEFINE_PROGRAM
WAIT 20
{
x++; IF (x > 4) x = 1;
ON[dvRelay,x] // This works as expected: only 1 relay of relays 1 to 4 will be on at a time
[dvRelay,x + 4] = x // This works as expected: only 1 relay of relays 5 to 8 will be on at a time
}
```

DEVICE Keywords

NetLinx supports the following DEVICE keywords:

DEVICE Keywords	
DEVICE_ID	<p>Every device in the NetLinx system has a unique ID number identifying its device type, such as an infrared/serial card or touch panel. The DEVICE_ID keyword returns the ID number pertaining to the specified device. If the device does not exist in the system, zero is returned. This keyword is usually used to determine whether or not a device is present in the system.</p> <pre>DeviceID = DEVICE_ID(Device)</pre> <p>For example:</p> <pre>IF (DEVICE_ID(55:1:0) <> 0) { // device 55 exists in the system }</pre>
DEVICE_ID_STRING	<p>This keyword returns a string description/model number for the specified device.</p> <pre>DeviceString = DEVICE_ID_STRING(55:1:0)</pre>
DEVICE_INFO	<p>NetLinx stores information, such as manufacturer, device name and device ID, for each device in the system. The DEVICE_INFO keyword allows a programmer to access all available information for any device. If the device does not exist in the system, a Device ID of zero is returned. This keyword is usually used to determine the firmware version of a device in the system.</p> <pre>DEVICE_INFO(DEV Device, DEV_INFO_STRUCT Info)</pre> <p>Parameters:</p> <ul style="list-style-type: none"> Device: The device to query. Info: A DEV_INFO_STRUCT variable to populate with the device information. <p>Result: DEVICE_INFO does not return a result. However, if the DEVICE_INFO call is successful, the DEVICE_ID element of the structure will be non-zero. If DEVICE_ID is zero, the structure contains no useful information.</p> <p>The DEV_INFO_STRUCT contains the following information:</p> <ul style="list-style-type: none"> Info. MANUFACTURER_STRING - A string identifying the manufacturer of the device. Info. MANUFACTURER - A integer identifying the manufacturer. Info. DEVICE_ID_STRING - A string description/model number for the specified device. This is the same information returned by the DEVICE_ID_STRING keyword. Info. DEVICE_ID - A unique ID number identifying its device type, such as an infrared/serial card or touch panel. This is the same information returned by the DEVICE_ID keyword. Info. VERSION - A string identifying the firmware version of the device. This is not available for AxLink devices. Info. FIRMWARE_ID - A unique ID number identifying the firmware for this device. This is not available for AxLink devices. Info. SERIAL_NUMBER - A 16-character serial number of the specified device. The serial number of every device is established when manufactured. This is the same information returned by GET_SERIAL_NUMBER keyword. This is not available for AxLink devices. Info. SOURCE_TYPE - An integer identifying how the device is connected to the master. This value can be any of the following: <ul style="list-style-type: none"> \$00 (SOURCE_TYPE_NO_ADDRESS) - There is no source address. \$01 (SOURCE_TYPE_NEURON_ID) - The device is connected via ICSNet. \$02 (SOURCE_TYPE_IP_ADDRESS) - The device is connected via IP. \$03 (SOURCE_TYPE_AXLINK) - The device is connected via ICSNet. \$06 (SOURCE_TYPE_IPv4_PORT_MAC_ADDRESS) - The device is connected via IP. \$10 (SOURCE_TYPE_NEURON_SUBNODE_ICSP) - The device is connected via ICSNet. \$11 (SOURCE_TYPE_NEURON_SUBNODE_PL) - The device is connected via ICSNet. \$12 (SOURCE_TYPE_IP_SOCKET_ADDRESS) - This device is a NetLinx socket. \$13 (SOURCE_TYPE_RS232) - This device is connected via RS232. \$18 (SOURCE_TYPE_IPv4_PORT_MAC_IPv6) - The device is connected via IP. \$20 (SOURCE_TYPE_INTERNAL) - This device is internal to the NetLinx controlled. Info. SOURCE_STRING - A string identifying the source address. Normally, this contains only useful information when Info.SOURCE_TYPE is \$02 (IP), in which case this contains the IP address of the device. <p>Example:</p> <pre>DEFINE_DEVICE dvNL = 0:1:0 DEFINE_VARIABLE DEV_INFO_STRUCT sDeviceInfo DEFINE_EVENT DATA_EVENT[dvNL] { ONLINE: { DEVICE_INFO(dvNL, sDeviceInfo) SEND_STRING 0, "MANUFACTURER_STRING=", sDeviceInfo.MANUFACTURER_STRING" SEND_STRING 0, "MANUFACTURER=", ITOA(sDeviceInfo.MANUFACTURER) " SEND_STRING 0, "DEVICE_ID_STRING=", sDeviceInfo.DEVICE_ID_STRING" SEND_STRING 0, "DEVICE_ID=", ITOA(sDeviceInfo.DEVICE_ID) " SEND_STRING 0, "VERSION=", sDeviceInfo.VERSION" SEND_STRING 0, "FIRMWARE_ID=", ITOA(sDeviceInfo.FIRMWARE_ID) " SEND_STRING 0, "SERIAL_NUMBER=", sDeviceInfo.SERIAL_NUMBER" SEND_STRING 0, "SOURCE_TYPE=", ITOA(sDeviceInfo.SOURCE_TYPE) " SEND_STRING 0, "SOURCE_STRING=", sDeviceInfo.SOURCE_STRING" } }</pre>

DEVICE Keywords (Cont.)	
DEVICE_INFO (Cont.)	Telnet displays this information: MANUFACTURER_STRING=AMX Corp. MANUFACTURER=1 DEVICE_ID_STRING=NXC-ME260 DEVICE_ID=256 VERSION=v2.30.128 FIRMWARE_ID=256 SERIAL_NUMBER=2010-00372 SOURCE_TYPE=1 SOURCE_STRING=00A066452001
DEVICE_STANDBY	This command requests that a device goes to standby state. If the device supports the standby state, the device will transition to standby, generating an asynchronous STANDBY DATA_EVENT. Example: DEVICE_STANDBY (DEVICE, NORMAL_STANDBY)
DEVICE_WAKE	This command requests that a device in standby state wake up. If the device both supports and is in standby state, it will transition to awake, generating an asynchronous AWAKE DATA_EVENT (see page 54). Example: DEVICE_WAKE (DEVICE, NORMAL_WAKE) Due to the nature of STANDBY state, a device in standby syncs with the master at regular intervals. The request to wake will not be processed until one of these sync events. So the AWAKE state will appear delayed.
DYNAMIC_APPLICATION_DEVICE	Specifies a Duet device that is completely dynamic. A dynamically discovered device matching the specified deviceType could be bound to the duetDevice from anywhere in the system. DYNAMIC_APPLICATION_DEVICE (DEV duetDevice, char[] deviceType, char[] friendlyName)
MASTER_SLOT	This keyword represents the slot number the master card is plugged into. "0" is the primary master; "1" is the secondary master. This keyword is primarily associated with Access systems. NetLinX systems have only one master, so MASTER_SLOT in NetLinX is always "0".
PUSH_DEVICE	See page 121.
RELEASE_DEVICE	See page 121.
PUSH_DEVCHAN	See page 121.
RELEASE_DEVCHAN	See page 121.
REBOOT	This keyword causes the device to reset and is equivalent to doing a power down and up on the master. REBOOT (DEVICE) Parameters: • DEVICE = ICSP device number to reboot. NOTE: Not all ICSP devices implement the reboot command. DEVICE refers to: - Device – a single device number. - Dps – a DEV structure. - D:P:S – a device specification such as 128:1:0. - DEV[] – a device array. Examples: REBOOT (0:0:0) or REBOOT (0:1:0) or REBOOT (0) Any of these examples will cause the master to reboot.
SEND_COMMAND	This keyword sends device-specific commands to a NetLinX device. Syntax: SEND_COMMAND DEV, '<command string>' - or - SEND_COMMAND DEV[], '<command string>'
SYSTEM_NUMBER	This keyword defines an unsigned 16-bit integer system constant that contains the system number.

Encode / Decode Keywords

Overview - Encoding and Decoding Binary and XML

There are six functions used to encode and decode variables in NetLinx. This encoding process takes a NetLinx variable, no matter how complex, and converts it into a string. The decode process will take this string and copy the contents back into a variable. These functions can be used to take the contents of NetLinx variables and convert them to string. Once the variable exists in string form, it can then be sent across an RS-232 connection, sent over an IP socket or saved to the NetLinx master's file system (disc on chip). Once the string is retrieved, either from a data event or by reading the information from the NetLinx master's file system, the data can be converted back to a variable.

There are two versions of this encoding and decoding: Binary and XML.

- The binary conversion routines are: STRING_TO_VARIABLE, VARIABLE_TO_STRING and LENGTH_VARIABLE_TO_STRING.
- The XML routines are XML_TO_VARIABLE, VARIABLE_TO_XML and LENGTH_VARIABLE_TO_XML.

Both sets of routines accomplish the same function but the encoded string differs in protocol. The binary conversion routines use a compact binary representation of the variable while the XML represents the variable as an ASCII text only XML document.

The binary routines are ideal when sending data from one NetLinx system to another NetLinx system over RS-232 or IP since the variable will be as compact as possible. It is also ideal for saving a file to the NetLinx master's file system if you do not intend to edit the file later. The binary routines encode and decode a variable sequentially meaning that the order and type of the variables must match on both the encoding and decoding side.

The XML routines are ideal when sending data from one NetLinx system to another type of system over RS232 or IP, since XML is more universally accepted by other types of computer systems. XML is also ideal for saving a file to the NetLinx master's file system if you intend to edit the file later since it is entirely ASCII text. It should be noted that while the XML is more universal, it is not very compact. The XML routines encode and decode a variable non-sequentially, meaning that the order and type of variables do not need to match on both the encoding and decoding side.

Below are some examples of how to use these encoding routines:

```
PROGRAM_NAME='ConversionExample'

(*{PS_SOURCE_INFO(PROGRAM STATS)
(*****
(* FILE_CREATED_ON: 05/22/2001 AT: 11:09:27
(*****
(* FILE_LAST_MODIFIED_ON: 05/22/2001 AT: 11:26:44
(*****
(* ORPHAN_FILE_PLATFORM: 1
(*****
(*!!FILE REVISION:
(* REVISION DATE: 05/22/2001
(*
(* COMMENTS:
(*
(*****
(*)}PS_SOURCE_INFO
(*****
(*****
(* System Type : NetLinx
(*****
(* REV HISTORY:
(*****

(*****
(* DEVICE NUMBER DEFINITIONS GO BELOW
(*****

DEFINE_DEVICE
dvTP = 128:1:0

(*****
(* CONSTANT DEFINITIONS GO BELOW
(*****

DEFINE_CONSTANT
nFileRead = 1
nFileWrite = 2
```

```

(*****
(*          DATA TYPE DEFINITIONS GO BELOW          *)
(*****

DEFINE_TYPE
STRUCTURE _AlbumStruct
{
    LONG      lTitleID
    CHAR      sArtist[100]
    CHAR      sTitle[100]
    CHAR      sCopyright[100]
    CHAR      sLabel[100]
    CHAR      sReleaseDate[100]
    INTEGER   nNumTracks
    CHAR      sCode[100]
    INTEGER   nDiscNumber
}
STRUCTURE _AlbumStruct2
{
    CHAR      sArtist[100]
    CHAR      sTitle[100]
    INTEGER   nNumTracks}

(*****
(*          VARIABLE DEFINITIONS GO BELOW          *)
(*****

DEFINE_VARIABLE
VOLATILE _AlbumStruct   AlbumStruct[3]
VOLATILE _AlbumStruct2 AlbumStruct2[3]
AlbumStruct2[3]
VOLATILE CHAR           sBinaryString[10000]
VOLATILE CHAR           sXMLString[50000]
VOLATILE LONG           lPos
VOLATILE SLONG          slFile
VOLATILE SLONG          slReturn

(*****
(*          STARTUP CODE GOES BELOW          *)
(*****

DEFINE_START
(* assign some values *)
AlbumStruct[1].lTitleID = 11101000
AlbumStruct[1].sArtist = 'Buffet, Jimmy'
AlbumStruct[1].sTitle = 'Living & Dying in 3/4 Time'
AlbumStruct[1].sCopyright = 'MCA'
AlbumStruct[1].sLabel = 'MCA'
AlbumStruct[1].sReleaseDate = '1974'
AlbumStruct[1].nNumTracks = 11
AlbumStruct[1].sCode = '3132333435'
AlbumStruct[1].nDiscNumber = 91
AlbumStruct[2].lTitleID = 17248229
AlbumStruct[2].sArtist = 'Buffet, Jimmy'
AlbumStruct[2].sTitle = 'Off to See the Lizard'
AlbumStruct[2].sCopyright = 'MCA'
AlbumStruct[2].sLabel = 'MCA'
AlbumStruct[2].sReleaseDate = '1989'
AlbumStruct[2].nNumTracks = 11
AlbumStruct[2].sCode = '3132333436'
AlbumStruct[2].nDiscNumber = 105
AlbumStruct[3].lTitleID = 12328612
AlbumStruct[3].sArtist = 'Buffet, Jimmy'
AlbumStruct[3].sTitle = 'A-1-A'
AlbumStruct[3].sCopyright = 'MCA'
AlbumStruct[3].sLabel = 'MCA'
AlbumStruct[3].sReleaseDate = '1974'
AlbumStruct[3].nNumTracks = 11
AlbumStruct[3].sCode = '3132333437'
AlbumStruct[3].nDiscNumber = 189

```

```

(*****
(*           THE EVENTS GO BELOW           *)
(*****

DEFINE_EVENT
(* CONVERT AND SAVE *)
BUTTON_EVENT[dvTP,1]
{
    PUSH:
    {
        (* CONVERT TO BINARY *)
        lPos = 1
        slReturn = VARIABLE_TO_STRING (AlbumStruct,sBinaryString,lPos)
        SEND_STRING 0,"'POSITION=',ITOA(lPos),' ; RETURN=',ITOA(slReturn)"

        (* CONVERT TO XML *)
        lPos = 1
        slReturn = VARIABLE_TO_XML (AlbumStruct,sXMLString,lPos,0)
        SEND_STRING 0,"'POSITION=',ITOA(lPos),' ; RETURN=',ITOA(slReturn)"
        (* NOW WE CAN SAVE THESE BOTH TO DISCS *)
        slFile = FILE_OPEN('BinaryEncode.xml',nFileWrite)
        IF (slFile > 0)
        {
            slReturn = FILE_WRITE(slFile,sBinaryString,LENGTH_STRING(sBinaryString))
            IF (slReturn < 0) SEND_STRING 0,"'FILE WRITE FAIL RETURN=',ITOA(slReturn)"
            slReturn = FILE_CLOSE(slFile)
            IF (slReturn < 0) SEND_STRING 0,"'FILE CLOSE FAIL RETURN=',ITOA(slReturn)"
        }
        slFile = FILE_OPEN('XMLEncode.xml',nFileWrite)
        IF (slFile > 0)
        {
            slReturn = FILE_WRITE(slFile,sXMLString,LENGTH_STRING(sXMLString))
            IF (slReturn < 0) SEND_STRING 0,"'FILE WRITE FAIL RETURN=',ITOA(slReturn)"
            slReturn = FILE_CLOSE(slFile)
            IF (slReturn < 0) SEND_STRING 0,"'FILE CLOSE FAIL

RETURN=',ITOA(slReturn)"
        }
        (* Clear string *)
        sBinaryString = ""
        sXMLString = ""
    }
}
(* READ AND DECODE *)
BUTTON_EVENT[dvTP,2]
{
    PUSH:
    {
        (* NOW WE CAN SAVE THESE BOTH TO DISCS *)
        slFile = FILE_OPEN('BinaryEncode.xml',nFileRead)
        IF (slFile > 0)
        {
            slReturn = FILE_READ(slFile,sBinaryString,MAX_LENGTH_STRING(sBinaryString))
            IF (slReturn < 0) SEND_STRING 0,"'FILE WRITE FAIL RETURN=',ITOA(slReturn)"
            slReturn = FILE_CLOSE(slFile)
            IF (slReturn < 0) SEND_STRING 0,"'FILE CLOSE FAIL RETURN=',ITOA(slReturn)"
        }
        slFile = FILE_OPEN('XMLEncode.xml',nFileRead)

IF (slFile > 0)
    {
        slReturn = FILE_READ(slFile,sXMLString,MAX_LENGTH_STRING(sXMLString))
        IF (slReturn < 0) SEND_STRING 0,"'FILE WRITE FAIL RETURN=',ITOA(slReturn)"
        slReturn = FILE_CLOSE(slFile)
        IF (slReturn < 0) SEND_STRING 0,"'FILE CLOSE FAIL RETURN=',ITOA(slReturn)"
    }
    (* CONVERT TO BINARY *)
    lPos = 1
    slReturn = STRING_TO_VARIABLE (AlbumStruct,sBinaryString,lPos)
    SEND_STRING 0,"'POSITION=',ITOA(lPos),' ; RETURN=',ITOA(slReturn)"
    (* CONVERT TO XML *)
    lPos = 1
    slReturn = XML_TO_VARIABLE (AlbumStruct,sXMLString,lPos,0)
    SEND_STRING 0,"'POSITION=',ITOA(lPos),' ; RETURN=',ITOA(slReturn)"
}
}

```

```

(* READ AND DECODE *)
(* THE BINARY WILL FAIL SINCE THE DECODE TYPE DOES NOT MATCH THE ENCODE TYPE *)
(* THE XML WILL NOT FAIL SINCE IT DOES NOT REQUIRE DATA TO BE THE SEQUENTIAL *)

BUTTON_EVENT[dvTP,3]
{
  PUSH:
  {
    (* NOW WE CAN SAVE THESE BOTH TO DISCS *)
    slFile = FILE_OPEN('BinaryEncode.xml',nFileRead)
    IF (slFile > 0)
    {
      slReturn = FILE_READ(slFile,sBinaryString,MAX_LENGTH_STRING(sBinaryString))
      IF (slReturn < 0) SEND_STRING 0,"'FILE WRITE FAIL RETURN=',ITOA(slReturn)"
      slReturn = FILE_CLOSE(slFile)
      IF (slReturn < 0) SEND_STRING 0,"'FILE CLOSE FAIL RETURN=',ITOA(slReturn)"
    }
    slFile = FILE_OPEN('XMLEncode.xml',nFileRead)
    IF (slFile > 0)
    {
      slReturn = FILE_READ(slFile,sXMLString,MAX_LENGTH_STRING(sXMLString))
      IF (slReturn < 0) SEND_STRING 0,"'FILE WRITE FAIL RETURN=',ITOA(slReturn)"
      slReturn = FILE_CLOSE(slFile)
      IF (slReturn < 0) SEND_STRING 0,"'FILE CLOSE FAIL RETURN=',ITOA(slReturn)"
    }
    (* CONVERT TO BINARY *)
    lPos = 1
    slReturn = STRING_TO_VARIABLE (AlbumStruct2,sBinaryString,lPos)
    SEND_STRING 0,"'POSITION=',ITOA(lPos),'; RETURN=',ITOA(slReturn)"
    (* CONVERT TO XML *)
    lPos = 1
    slReturn = XML_TO_VARIABLE (AlbumStruct2,sXMLString,lPos,0)
    SEND_STRING 0,"'POSITION=',ITOA(lPos),'; RETURN=',ITOA(slReturn)"
  }
}
(*****
(*          THE ACTUAL PROGRAM GOES BELOW          *)
(*****

DEFINE_PROGRAM

(*****
(*          END OF PROGRAM          *)
(*          DO NOT PUT ANY CODE BELOW THIS COMMENT          *)
(*****

```

Encode / Decode Keywords

The NetLinx programming language supports the following Encode & Decode keywords:

Encode / Decode Keywords	
STRING_TO_VARIABLE (VARIABLE DECODE)	<p>This routine takes the Encode data from buffer and loads the values into the DECODE variable. The DECODE variable must match the type of the variables in the encoded string. When the ENCODE variable is a structure, the decode variable members must match in type and order. If the number of members of the structures doesn't match then the routine will fill all it can or skip any unused data members.</p> <pre>SINTEGER STRING_TO_VARIABLE (DECODE, CHAR BUFFER[], LONG POSITION)</pre> <p>Parameters:</p> <ul style="list-style-type: none"> • DECODE: Any type of variable. This is the variable to be decoded into. • BUFFER: Must be of char array type. This is where the encoded data is found. • POSITION: This is where the first byte of the decode data. It is also modified to point to the next location after the last decoded byte. That means that successive calls to this function can be made without modifying position. The position should be set to one on the first call. <p>Result:</p> <ul style="list-style-type: none"> • 2: Decode data too small, more members in structure • 1: Structure too small, more members in decode string • 0: Decoded OK • -1: Decode variable type mismatch • -2: Decode data too small, decoder ran out of data
VARIABLE_TO_STRING (VARIABLE ENCODE)	<p>This routine takes the variable ENCODE and creates entries in the buffer to represent that variable. The variable passed in can be of any type including arrays, structures, and arrays of structures.</p> <pre>SINTEGER VARIABLE_TO_STRING(ENCODE, CHAR BUFFER[], LONG POSITION)</pre> <p>Parameters:</p> <ul style="list-style-type: none"> • ENCODE: Any type of variable. This is the variable to be encoded. • BUFFER: This is where the encode data is placed. • POSITION: This is where the first byte of the encoding is placed. Is it also modified to point to the next location after the last encoded byte. That means that successive calls to this function can be made without modifying position. Position should be set to one on the first call. <p>Result:</p> <ul style="list-style-type: none"> • 0: Encoded OK • -1: Encoded variable unrecognized type • -2: Encoded data would not fit into buffer; the buffer is too small. <pre>Result = VARIABLE TO STRING (MyStruct, Buffer, Pos)</pre>
LENGTH_VARIABLE_TO_STRING (VARIABLE Encode)	<p>This routine calculates how many bytes it takes to encode a variable.</p> <pre>LONG LENGTH_VARIABLE_TO_STRING (VARIABLE Encode)</pre> <p>Parameters:</p> <ul style="list-style-type: none"> • Encode: The variable (any type) to be encoded. <p>Result:</p> <ul style="list-style-type: none"> • >0: Number of bytes required to encode variable. • 0: Encoded variable error, unrecognized type <p>Syntax:</p> <pre>LONG LENGTH_VARIABLE_TO_STRING (CONSTANT VARIANTARRAY A)</pre> <p>Where:</p> <ul style="list-style-type: none"> • A is the variable (any type) to be encoded.

Encode / Decode Keywords (Cont.)	
LENGTH_VARIABLE_TO_XML	<p>Syntax: LONG LENGTH_VARIABLE_TO_XML (CONSTANT VARIANTARRAY A, LONG B)</p> <p>Where:</p> <ul style="list-style-type: none"> • A is the variable (any type) to be encoded. • B is the encoding flag. These can be used together. <p>Value \$01 is "Encode with Types". If the bit is set, types will be included for every variable being encoded. The default is to not include types.</p> <p>Value \$10 is "Encoded CHAR arrays as using data list". See <i>Binary Array Encoding</i> on page 223.</p> <p>Value \$20 is "Array Encoding is Little-Ending".</p> <p>The return is the length needed to encode the variable.</p>
VARIABLE_TO_XML	<p>Syntax: SINTEGER VARIABLE_TO_XML (CONSTANT VARIANTARRAY A, CHAR B[], LONG C, LONG D)</p> <p>Where:</p> <ul style="list-style-type: none"> • A is the variable (any type) to be encoded: • B is the CHAR array to hold the resulting XML. • C is the beginning encoding position. Encoding will start as B[C]. • D is the encoding flag. These can be used together. <p>Value \$01 is "Encode with Types". If the bit is set, types will be included for every variable being encoded. The default is to not include types. The constant XML_ENCODE_TYPES can be used to specify this flag.</p> <p>Value \$10 is "Encoded CHAR arrays as using data list". The constant XML_ENCODE_CHAR_AS_LIST can be used to specify this flag. See the Encoding and Decoding: Binary and XML section on page 175.</p> <p>Value \$20 is "Array Encoding is Little-Ending". The constant XML_ENCODE_LE can be used to specify this flag.</p> <p>Return:</p> <ul style="list-style-type: none"> 0 = Encode was OK -3 = Output CHAR buffer was too small <p>Example:</p> <pre> DEFINE_TYPE STRUCTURE _AlbumStruct { LONG lTitleID CHAR sArtist[100] CHAR sTitle[100] } DEFINE_VARIABLE _AlbumStruct MyAlbumStruct[3] LONG lPos SLONG slReturn SLONG slFile SLONG slResult CHAR sBinaryString[10000] CHAR sXMLString[50000] DEFINE_START MyAlbumStruct[1].lTitleID = 11101000 MyAlbumStruct[1].sArtist = 'Buffet, Jimmy' MyAlbumStruct[1].sTitle = 'Living & Dying in % Time' MyAlbumStruct[2].lTitleID = 11101012 MyAlbumStruct[2].sArtist = 'Sinatra, Frank' MyAlbumStruct[2].sTitle = 'Come Fly With Me' MyAlbumStruct[3].lTitleID = 33101000 MyAlbumStruct[3].sArtist = 'Holiday, Billie' MyAlbumStruct[3].sTitle = 'Lady in satin' DEFINE_EVENT BUTTON_EVENT[TP,1] //Convert And Save { PUSH: { // Convert To Binary lPos = 1 slReturn = VARIABLE_TO_STRING(MyAlbumStruct, sBinaryString, lPos) SEND_STRING 0,"'POSITION=',ITOA(lPos),' - Result = ',ITOA(slReturn)" // Convert To XML lPos = 1 slReturn = VARIABLE_TO_XML(MyAlbumStruct, sXMLString, lPos, 0) SEND_STRING 0,"'POSITION=',ITOA(lPos),' - Result = ',ITOA(slReturn)" </pre>

Encode / Decode Keywords (Cont.)	
VARIABLE_TO_XML (Cont.)	<pre>// Save Structure to Disk - Binary slFile = FILE_OPEN('BinaryEncode.xml', 2) slReturn = FILE_WRITE(slFile, sBinaryString, LENGTH_STRING(sBinaryString)) slReturn = FILE_CLOSE(slFile) // Save Structure To Disk - XML slFile = FILE_OPEN('xmlEncode.xml', 2) slReturn = FILE_WRITE(slFile, sXMLString, LENGTH_STRING(sXMLString)) slReturn = FILE_CLOSE(slFile) } RELEASE: { } } BUTTON_EVENT[TP,2] // Read and Decode { PUSH: { // Read Binary File slFile = FILE_OPEN('BinaryEncode.xml',1) slResult = FILE_READ(slFile, sBinaryString, MAX_LENGTH_STRING(sBinaryString)) slResult = FILE_CLOSE (slFile) // Read XML File slFile = FILE_OPEN('XMLEncode.xml',1) slResult = FILE_READ(slFile, sXMLString, MAX_LENGTH_STRING(sXMLString)) slResult = FILE_CLOSE (slFile) } } RELEASE: { } } // Convert To Binary lPos = 1 slReturn = STRING_TO_VARIABLE(MyAlbumStruct, sBinaryString, slPos) // OR Convert To XML slPos = 1 slReturn = XML_TO_VARIABLE (MyAlbumStruct, sXMLString, slPos, 0)</pre>
XML_TO_VARIABLE	<p>Syntax: SINTEGER XML_TO_VARIABLE (VARIANTARRAY A, CONSTANT CHAR B[], LONG C, LONG D)</p> <p>Where:</p> <ul style="list-style-type: none"> • A is the variable (any type) to be decoded. • B is the CHAR array holding the source XML. • C is the next beginning encoding position. Encoding ended at B[C-1]. • D are the decoding flags. They can be used together. <p><i>Value \$01</i> is "Force Types When Decoding". If the type in the XML does not match the variable typed being decoded to, the variable will not be written and the variable will be skipped in the XML. The constant XML_DECODE_TYPES can be used to specify this flag.</p> <p><i>Value \$10</i> is "Do Not preserve current value of A". If set, A will be cleared if not explicitly set. The constant XML_DECODE_NO_PRESERVE can be used to specify this flag.</p> <p>Return:</p> <ul style="list-style-type: none"> 3 = XML decode data type mismatch 2 = XML decode data too small, more members in structure 1 = Structure too small, more members in XML decode string 0 = Decode was OK -1 = Decode variable type mismatch -2 = Decode data too small, decoder ran out of data. Most likely poorly formed XML <p>Example:</p> <pre>DEFINE_TYPE STRUCTURE _AlbumStruct { LONG lTitleID CHAR sArtist[100] CHAR sTitle[100] }</pre>

Encode / Decode Keywords (Cont.)**XML_TO_VARIABLE (Cont.)**

```

DEFINE_VARIABLE
_AlbumStruct MyAlbumStruct[3]
LONG lPos
SLONG slReturn
SLONG slFile
SLONG slResult
CHAR sBinaryString[10000]
CHAR sXMLString[50000]

DEFINE_START
MyAlbumStruct[1].lTitleID = 11101000
MyAlbumStruct[1].sArtist = 'Buffet, Jimmy'
MyAlbumStruct[1].sTitle = 'Living & Dying in % Time'
MyAlbumStruct[2].lTitleID = 11101012
MyAlbumStruct[2].sArtist = 'Sinatra, Frank'
MyAlbumStruct[2].sTitle = 'Come Fly With Me'
MyAlbumStruct[3].lTitleID = 33101000
MyAlbumStruct[3].sArtist = 'Holiday, Billie'
MyAlbumStruct[3].sTitle = 'Lady in satin'
DEFINE_EVENT
BUTTON_EVENT[TP,1] // Convert And Save
{
PUSH:
{
// Convert To Binary
lPos = 1
slReturn = VARIABLE_TO_STRING(MyAlbumStruct, sBinaryString, lPos)
SEND_STRING 0, "POSITION=", ITOA(lPos), " - Result = ", ITOA(slReturn)
// Convert To XML
lPos = 1
slReturn = VARIABLE_TO_XML(MyAlbumStruct, sXMLString, lPos, 0)
SEND_STRING 0, "POSITION=", ITOA(lPos), " - Result = ", ITOA(slReturn)
// Save Structure to Disk - Binary
slFile = FILE_OPEN('BinaryEncode.xml', 2)
slReturn = FILE_WRITE(slFile, sBinaryString, LENGTH_STRING(sBinaryString))
slReturn = FILE_CLOSE(slFile)
// Save Structure To Disk - XML
slFile = FILE_OPEN('xmlEncode.xml', 2)
slReturn = FILE_WRITE(slFile, sXMLString, LENGTH_STRING(sXMLString))
slReturn = FILE_CLOSE(slFile)
}
}
RELEASE:
{
}
}
BUTTON_EVENT[TP,2] // Read and Decode
{
PUSH:
{
// Read Binary File
slFile = FILE_OPEN('BinaryEncode.xml',1)
slResult = FILE_READ(slFile, sBinaryString, MAX_LENGTH_STRING(sBinaryString))
slResult = FILE_CLOSE (slFile)
// Read XML File
slFile = FILE_OPEN('XMLEncode.xml',1)
slResult = FILE_READ(slFile, sXMLString, MAX_LENGTH_STRING(sXMLString))
slResult = FILE_CLOSE (slFile)
// Convert To Binary
lPos = 1
slReturn = STRING_TO_VARIABLE(MyAlbumStruct, sBinaryString, slPos)
// OR Convert To XML
slPos = 1
slReturn = XML_TO_VARIABLE (MyAlbumStruct, sXMLString, slPos, 0)
}
}
RELEASE:
{
}
}

```

Event Handler Keywords

Overview

NetLinx provides a special program section called `DEFINE_EVENT` to define handlers for incoming events/notifications. These handlers are stored in an event table providing quick access to code that must be executed when an event is received. There are handlers to support five types of events:

- Button events include pushes, releases, and holds, which are associated with a push or release on a particular device-channel.
- Channel events occur when an output change (On/Off) is detected on a device-channel.
- Data events include commands, strings, status, and error messages.
- Level events are received as a result of a level change on a particular device.
- Timeline events trigger events based on a sequence of times.

NOTE: *The processing of an event associated with a given member of a device, channel, device-channel, level, or device-level array must be completed before processing can begin on another event associated with the same array.*

All incoming events are stored in a queue pending processing. Messages are processed in the order they are received. The steps to processing an event are:

1. Check all events for a handler matching the specified event. If a handler is found, run it.
2. If there is no event handler, run MAINLINE.

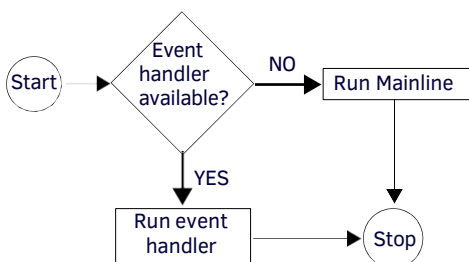

FIG. 2 Processing an Event

NOTE: *More than one handler can be defined for the same event. In this case, the handlers are executed in the order in which they are defined in the program.*

The event handler descriptions are:

- **DEVICE** refers to a device specification:
 - `DEVICE` A single device number constant
 - `D:P:S` A constant device specification such as 128:1:0
 - `DEV []` A device array
- **CHANNEL** refers to:
 - `CHANNEL` A single channel number constant
 - `CHAN []` An integer array of channel numbers
 - `DEVCHAN []` A device-channel array
- **LEVEL** refers to:
 - `LEVEL` A single level number constant
 - `LEV []` An integer array of level numbers
 - `DEVLEV []` A device-level array

NOTE: *The processing of an event associated with a given member of a device, channel, device-channel, level, or device-array must be completed before processing can begin on another event associated with the same array.*

Button Events

Events associated with a button on a touch panel or keypad are referred to as *Button Events*. Button events include pushes, releases, and holds. These events are associated with a push or release on a particular device-channel.

The format for a Button Event is shown below:

```

BUTTON_EVENT[DEVICE,CHANNEL] or BUTTON_EVENT[(DEVCHAN[ ])]
{
    PUSH:
    {
        // PUSH event handler
    }

    RELEASE:
    {
        // RELEASE event handler
    }

    HOLD[TIME]: or HOLD[TIME, REPEAT]:
    {
        // HOLD event handler
    }
}

```

- The [<DEVICE>, <CHANNEL>] declaration can contain a DEV device set, or a DEVCHAN device-channel set in addition to individual device and channel declarations.
- A HOLD event handler specifies the actions that should be performed when a button is pressed and held for a minimum length of time indicated by the TIME parameter (TIME is specified in .10 second increments).
- The REPEAT keyword specifies that the event notification should be repeated in TIME increments as long as the button is held.
- The BUTTON object is available to the button event handler as a local variable. The following table lists the information contained in Button Objects.

Button Objects		
Property Name	Type	Description
Button.Input	DEVCHAN	The device, channel combination that caused the BUTTON_EVENT to happen.
Button.Input.Channel	INTEGER	The channel number that caused the BUTTON_EVENT to happen.
Button.Input.Device	DEV	The device that caused the BUTTON_EVENT to happen.
Button.Input.Device.Number	INTEGER	The device number of the device that caused the BUTTON_EVENT to happen.
Button.Input.Device.Port	INTEGER	The port of the device that caused the BUTTON_EVENT to happen
Button.Input.Device.System	INTEGER	The system number of the device that caused the BUTTON_EVENT to happen
Button.Holdtime	LONG	Current hold time in one-millisecond (1 ms) increments
Button.SourceDev	DEV	Source device of button event. (This property is no longer used.)
Button.SourceDev.Number	INTEGER	Source device number. (This property is no longer used.)
Button.SourceDev.Port	INTEGER	Source device port. (This property is no longer used.)
Button.SourceDev.System	INTEGER	Source device system. (This property is no longer used.)

If the event handler is specified using an array for DEV,CHANNEL, or a DEVCHAN array, GET_LAST can determine which index in the array caused the event to run.

Channel Events

Channel Events are similar to Button Events. Channel Events are generated by ON, OFF, PULSE, TO, or MIN_TO.

The format for a Channel Event:

```

CHANNEL_EVENT[DEVICE,CHANNEL] or CHANNEL_EVENT[(DEVCHAN[ ])]
{
    ON:
    {
        // CHANNEL ON event handler
    }

    OFF:
    {
        // CHANNEL OFF event handler
    }
}

```

NOTE: The Channel object is available to the Channel Event handler as a local variable.

Like Button Events, the [<device>, <channel>] declaration can contain a DEV device set, or a DEVCHAN device-channel set in addition to individual device and channel declarations. In the following example, a Channel Event is defined for the 'Projector Lift Up' relay, telling the system to turn off the projector every time this relay is turned on:

```

DEFINE_EVENT
.
.
BUTTON_EVENT[TP1,21] (* LIFT UP BUTTON *)
{
    PUSH:
    {
        PULSE[RELAY,LIFT_UP]
    }
}

```

```

BUTTON_EVENT[TP1,22]          (* SYSTEM OFF BUTTON *)
{
  PUSH:
  {
    PULSE[RELAY,RACK_OFF]
    PULSE[RELAY,LIFT_UP]
  }
}

CHANNEL_EVENT[RELAY,LIFT_UP]  (* LIFT UP RELAY EVENT *)
{
  ON:
  {
    PULSE[VPROJ,VP_POWER_OFF]
  }
}

```

NOTE: Since turning on or pulsing the relay does not produce a push, a Button Event is not generated.

The following table lists the information contained in Channel events:

Channel Objects		
Property Name	Type	Description
Channel.Device	DEV	The device that caused the CHANNEL_EVENT to happen.
Channel.Device.Number	INTEGER	The device number of the device that caused the CHANNEL_EVENT to happen.
Channel.Device.Port	INTEGER	The port of the device that caused the CHANNEL_EVENT to happen.
Channel.Device.System	INTEGER	The system number of the device that caused the CHANNEL_EVENT to happen.
Channel.Channel	INTEGER	The channel number that caused the CHANNEL_EVENT to happen.
Channel.SourceDev	DEV	Source Device of Channel Event
Channel.SourceDev.Number	INTEGER	Source Device Number
Channel.SourceDev.Port	INTEGER	Source Device Port
Channel.SourceDev.System	INTEGER	Source Device System.

If the event handler is specified using an array for DEV, CHANNEL, or a DEVCHAN array, GET_LAST can be used to determine which index in the array caused the event to run.

Data Events

Data Events provide some interesting capabilities in a NetLinx system. At first glance, it seems to be concerned with receiving strings of data either from a serial data device (such as an NXC-COM2 card) or an interface device (such as a touch panel or keypad). While this is a valid function, DATA_EVENT has many more capabilities and works with many devices.

The format for Data Events:

```

DATA_EVENT[DEVICE]
{
  COMMAND:
  {
    // Command processing goes here
  }
  STRING:
  {
    // String processing goes here
  }
  ONLINE:
  {
    // OnLine processing goes here
  }
  OFFLINE:
  {
    // OffLine processing goes here
  }
  ONERROR:
  {
    // OnError processing goes here
  }
  STANDBY:
  {
    // Standby processing goes here
  }
  AWAKE:
  {
    // Awake processing goes here
  }
}

```

NOTE: The data object is available to the Data Event handler as a local variable.

The following table lists the information contained in data objects:

Data Objects		
Property Name	Type	Description
Data.Device	DEV	Device
Data.Device.Number	INTEGER	Device number
Data.Device.Port	INTEGER	Device port
Data.Device.System	INTEGER	System number
Data.Number	LONG	Event number
Data.SourceDev	DEV	Source Device of Data Event
Data.SourceDev.Number	INTEGER	Source Device Number
Data.SourceDev.Port	INTEGER	Source Device Port
Data.SourceDev.System	INTEGER	Source Device System
Data.Text	CHAR Array	Text Associated With the Event

- The *Event Number* is a number associated with a command, error condition or the device ID associated with an online/offline event. The numeric value is stored as either a floating-point number or integer, as appropriate; the value can be assigned to a variable of any numeric type. This field could be a value associated with a command event or error condition.
- *Text Associated with The Event* is associated with a command, string, or error notification. It can also be the device ID string in the case of an online/offline event.

The following table shows the fields that contain relevant information for data or notifications received via Internet protocol (IP):

Data Objects Received Via the Internet Protocol (IP)		
Property Name	Type	Description
Data.SourceIP	CHAR Array	IP address of the client/source application
Data.SourcePort	LONG	Server/source port number

Not all fields in the DATA object apply to all types of events. The following table lists the fields and the corresponding events. An 'X' indicates that the field applies (or could apply) to the given event.

Data Object Fields							
Property Name	Command	String	OnLine	OffLine	OnError	AWAKE	STANDBY
Data.Device	X	X	X	X	X	X	X
Data.Number			X	X	X	X	X
Data.Text	X	X	X	X	X	X	X
Data.SourceIP	X	X	X	X	X	X	X
Data.ServerIP	X	X	X	X	X	X	X
Data.SourcePort	X	X	X	X	X	X	X

NetLinX is able to process data received by a DATA_EVENT in real time. When data is received, it enters the message queue and triggers a data event. If a buffer has been created for the device, the data is placed within the buffer and can be used by either the DATA_EVENT or mainline. The data can be evaluated in two ways. The actual string that is received by the message queue can be evaluated using the DATA.TEXT object within the event. The string in DATA.TEXT is also added to the end of the device's buffer. This becomes a factor when receiving large strings, or when receiving strings with an embedded string length or start and end characters. DATA_EVENT then evaluates the buffer to see if the entire string has been received before processing it; however, the evaluation is done immediately upon receipt of another chunk of data, and is only done when data is received.

For example, DATA.TEXT may equal {'over the lazy brown dog',ETX} and the DATA_BUFFER[500] might equal {STX,'The quick gray fox jumps over the lazy brown dog',ETX}. By evaluating the buffer value, you can evaluate the entire string at once.

Two other important aspects of the DATA_EVENT are the ONLINE and OFFLINE event handlers. ONLINE and OFFLINE events are triggered when the master recognizes a device has come on the bus or has dropped off the bus.

NetLinX handles all device initializations and offline warning through the DATA_EVENT. Since every device triggers an ONLINE event when the master is reset, this not only ensures that the device will be initialized on startup, but also insures that the device will be initialized any time the device comes online. The DATA_EVENT is evaluated on a need to know basis, rather than on each pass through mainline.

The following example shows basic code for tracking a touch panel page:

- Assume that the variables have been properly defined in the DEFINE_VARIABLE section.
- The DEFINE_START section contains the creation of the buffer and the DEFINE_PROGRAM section contains the string evaluation.

```

DEFINE_START
CREATE_BUFFER TP1, TP1_BUFFER
.
.
DEFINE_EVENT
..
DATA_EVENT[TP1] (* EVALUATE TP1 DATA *)
{
    STRING:
    {
        SELECT
        {
            ACTIVE (FIND_STRING (DATA.TEXT, 'PAGE-',1)):
            {
                JUNK = REMOVE_STRING (DATA.TEXT, 'PAGE-',1)
                CUR_PAGE = DATA.TEXT
            }
            ACTIVE (FIND_STRING (DATA.TEXT, 'KEYP-',1)):
            {
                (* keypad code *)
            }
            ACTIVE (FIND_STRING (DATA.TEXT, 'KEYB-',1)):
            {
                (* keyboard code *)
            }
            ACTIVE (1):
            {
                (* default code *)
            }
        }
        CLEAR_BUFFER TP1_BUFFER
    }
    ONLINE:
    {
        SEND_COMMAND TP1, 'TPAGEON'
    }
}
.
.

```

Each event handler contains several embedded data objects that pass data values into the event handler code.

Level Events

Level Events are triggered by a level change on a particular device. This eliminates constantly evaluating a level against a previous value. The format for LEVEL_EVENTS:

```

LEVEL_EVENT[DEVICE,LEVEL] or LEVEL_EVENT{([DEVLEV[ ]])}
{
    // level event handler
}

```

NOTE: *The level object is available to the Level Event handler as a local variable.*

It contains the information shown in the table below: |

Level Objects		
Property Name	Type	Description
Level.Input	DEVLEV	Device + Level that caused the event to occur
Level.Input.Device	DEV	The device that caused the LEVEL_EVENT to happen
Level.Input.Device.Number	INTEGER	The device number of the device that caused the LEVEL_EVENT to happen.
Level.Input.Device.Port	INTEGER	The level port of the bargraph that caused the LEVEL_EVENT to happen.
Level.Input.Device.System	INTEGER	The system number of the device that caused the LEVEL_EVENT to happen.
Level.Input.Level	INTEGER	The level code of the bargraph that caused the LEVEL_EVENT to happen.
Level.SourceDev	DEV	Source Device of Level Event
Level.SourceDev.Number	INTEGER	Source Device Number
Level.SourceDev.Port	INTEGER	Source Device Port
Level.SourceDev.System	INTEGER	Source Device System
Level.Value	Numeric	The value of the bargraph when the LEVEL_EVENT occurred.

LEVEL_VALUE is an embedded object value in the LEVEL_EVENT statement. If the event handler is specified using an array for DEV, CHANNEL, or a DEVCHAN array, GET_LAST can be used to determine which index in the array caused the event to run. The numeric value is stored either as a floating-point number or integer, as appropriate; but the value can be assigned to a variable of any numeric type.

Example Level Event:

```

LEVEL_EVENT [ TEMP, 1 ]
{
  IF (LEVEL.VALUE >= COOL_POINT)
  {
    ON[RELAY,FAN]
  }
  ELSE IF (LEVEL.VALUE <= HEAT_POINT)
  {
    OFF[RELAY,FAN]
  }
}

```

Custom Events

A Custom Event is generated by certain devices in response to query commands or unique device events. For instance, G4 touch panels generate custom events in response to button query commands or mouse clicks. An example channel event is shown below:

```

CUSTOM_EVENT[DEVICE, ID, TYPE] or CUSTOM_EVENT[DEVCHAN, EVENTID]
{
}

```

The EVENTID is specific to each device. For instance, the EVENTID sent in response to a button text query command for G4 touch panels is 1001.

NOTE: For more information on *EVENTID* values and the values of the custom event for each *EVENTID*, see the programming section of the device manual with which you are working.

The following table lists the information contained in Custom events:

Channel Objects		
Property Name	Type	Description
Custom.Device	DEV	Device
Custom.Device.Number	INTEGER	Device number
Custom.Device.Port	INTEGER	Device port
Custom.Device.System	INTEGER	System number
Custom.ID	INTEGER	The ID of the custom event as defined by the device
Custom.Type	INTEGER	The TYPE of the custom event as defined by the device
Custom.Flag	INTEGER	A flag associated with the event
Custom.Value1	SLONG	The first value associated with the event
Custom.Value2	SLONG	The second value associated with the event
Custom.Value3	SLONG	The third value associated with the event
Custom.Text	CHAR[]	Text associated with the event
Custom.Encode	CHAR[]	A string encoded with VARIABLE_TO_STRING encoding for complex data types.
Custom.SourceDev	DEV	Source device of custom event
Custom.SourceDev.Number	INTEGER	Source device number
Custom.SourceDev.Port	INTEGER	Source device port
Custom.SourceDev.System	INTEGER	Source device system.

If the event handler is specified using an array for DEV, INTEGER, or a DEVCHAN array, GET_LAST can determine which index in the array caused the event to run.

Event Parameters

It has already been stated that DEFINE_EVENT handlers are stored in an event table providing quick access to code that must be executed when an event is received. The event table keeps a list of all events in a sorted order to more quickly determine which code needs to be accessed for a given incoming event. The event table is built before DEFINE_START runs and it not changed anytime after that. As a result, there are certain rules that must be applied to the parameters used in DEFINE_EVENTS.

Since the event table is built before DEFINE_START, all event parameters must contain the correct information prior to DEFINE_START. This requires that all EVENT parameters must be defined at compile time. In addition, many parameter "shortcuts" to help fulfill this requirement. Using BUTTON_EVENT as an example, the simplest version of event parameters is a device and channel reference. In the following example:

```

DEFINE_DEVICE
dvTp = 128:1:0

DEFINE_EVENT

BUTTON_EVENT[dvTp, 1]
{
  PUSH:
    SEND_STRING 0, 'Button 1 of dvTp was pushed'
}

```

The device, dvTp, was defined in the DEFINE_DEVICE section, which has the effect of making it an initialized variable of type DEV, and the channel number was a hard-coded value of 1. Since both of these values were defined at compile time, the event is entered into the event table correctly. Let's take another example:

```

DEFINE_DEVICE
dvTp = 128:1:0

DEFINE_VARIABLE
Integer nMyChannel

DEFINE_START
nMyChannel = 1

DEFINE_EVENT

BUTTON_EVENT[dvTp,nMyChannel]
{
    PUSH:
        Send_String 0,"'Button ',ITOA(nMyChannel),' of dvTp was pushed'"
}

```

In this example, the event will not perform as the previous one did. When the code is compiled, the event parameters are *dvTp*, which is already assigned, and *nMyChannel*, which has a value of 0. *nMyChannel* does not get assigned a value of 1 until `DEFINE_START`, at which time the event has already been added to the event table. If you were to run this code, you would discover that it did in fact run when button 1 was pushed, leading us to one of the "shortcuts":

NOTE: A value of 0 for a Channel or Level Number in a `BUTTON_EVENT`, `CHANNEL_EVENT` or `LEVEL_EVENT` will be interpreted as an event handler for all events of that type from the given device number(s).

So, the reason the above example runs when button 1 was pushed is that the above example runs when any button on *dvTp* is pushed. This "shortcut" was added so you could define an event handler for all buttons, channel or levels of a device without having to define a `DEVCHAN` of `DEVLEV` containing every value you may want to handle. To make the example 2 behave like the example 1, we simply need to make sure the value of *nMyChannel* contains a value of 1 at compile time. This is simply done by initializing *nMyChannel* a value of 1 in the `DEFINE_VARIABLE` section. The new example reads:

Example 3:

```

DEFINE_DEVICE
dvTp = 128:1:0

DEFINE_VARIABLE
Integer nMyChannel = 1

DEFINE_EVENT

BUTTON_EVENT[dvTp,nMyChannel]

{
    PUSH:
        Send_String 0,"'Button ',ITOA(nMyChannel),' of dvTp was pushed'"
}

```

You may be tempted to use a more traditional variable as the channel number, mainly `PUSH_CHANNEL` or `RELEASE_CHANNEL`. It is important to realize that the identifiers are nothing more than global (system) variable. At compile time, the values are defined and contain a value of 0. So the following code will have the effect you expect button probably for a different reason than you expect.

```

DEFINE_EVENT

BUTTON_EVENT[dvTp,PUSH_CHANNEL]
{
    PUSH:
        Send_String 0,"'Button ',ITOA(BUTTON.INPUT.CHANNEL),' of dvTp was pushed'"
    RELEASE:
        Send_String 0,"'Button ',ITOA(BUTTON.INPUT.CHANNEL),' of dvTp was released'"
}

```

Although the event will run for both the push and release of all buttons for *dvTp*, you may also be tempted to think that you need to make sure the event runs for `RELEASE_CHANNEL` by adding the following:

```

DEFINE_EVENT
BUTTON_EVENT[dvTp,PUSH_CHANNEL]
BUTTON_EVENT[dvTp,RELEASE_CHANNEL]
{
    PUSH:
        Send_String 0,"'Button ',ITOA(BUTTON.INPUT.CHANNEL),' of dvTp was pushed'"
    RELEASE:
        Send_String 0,"'Button ',ITOA(BUTTON.INPUT.CHANNEL),' of dvTp was released'"
}

```

However, since both `PUSH_CHANNEL` and `RELEASE_CHANNEL` have a value of 0 at compile time, you are in effect stacking two events that are interpreted as running for any button pushed on the panel and as a result, the event is run twice every time a button is pushed or released. This may not seem like a big problem until you try to toggle a variable in the event: since the event runs twice for every button push, the variable toggles on then toggles off again.

There are some additional parameter "shortcuts" available. In all cases, the following rules apply:

- When a `DEV` can be used, a `DEV` array can also be used.
- When a `DEVCHAN` can be used, a `DEVCHAN` array can be used.
- When a `DEVLEV` can be used, a `DEVLEV` array can be used.

- When a Char, Integer or Long can be used, a Char, Integer or Long array can also be used.
- You can apply more than 1 of the above rules at a time in a given event handler.
- GET_LAST() can be used to determine which index of an array (any type) caused the event to fire.

The above rules can let you write some interesting event handler. Let's say you wanted to handle 4 buttons from 6 panels all with one button event. You could write:

```

DEFINE_DEVICE
dvPanel1 = 128:1:0
dvPanel2 = 129:1:0
dvPanel3 = 130:1:0
dvPanel4 = 131:1:0
dvPanel5 = 132:1:0
dvPanel6 = 133:1:0

DEFINE_VARIABLE
DEV dvMyPanels[] = {dvPanel1, dvPanel2, dvPanel3, dvPanel4, dvPanel5, dvPanel6 }
INTEGER nMyButtons[] = { 4, 3, 2, 1 }
INTEGER nPanelIndex
INTEGER nButtonIndex
DEFINE_EVENT
BUTTON_EVENT[dvMyPanels,nMyButtons]
{
  PUSH:
  {
    nPanelIndex = GET_LAST(dvMyPanels)
    nButtonIndex = GET_LAST(nMyButtons)
    Send_String 0,"'Button Index=',ITOA(nButtonIndex),' was pushed on Panel Index=',ITOA(nPanelIndex)"
  }
}

```

This event will be run for all combinations of dvMyPanel and nMyButtons, 24 buttons in all. The GET_LAST() function is very useful when running event using array as parameters. GET_LAST() returns an index value, starting at 1, for the element that triggered the event. In the case of nButtonIndex, it will contain a value of 1 when button 4 was pressed, a value of 2 when button 3 was pressed... This can be very useful in the case of transmitters and wired panels where the channel number may not reflect a numerical sequence you would like, such as with Numeric Keypads.

Event Handler Keywords

The NetLinx programming language supports the following Event Handler keywords:

Event Handler Keywords	
BUTTON_EVENT	<p>Defines a button event handler and can only be used in the DEFINE_EVENT section of the program. This type of handler processes PUSH, RELEASE, and HOLD events.</p> <pre> BUTTON_EVENT[DEVICE,CHANNEL] or BUTTON_EVENT [(DEVCHAN [])] { PUSH: { // Push statements go here } RELEASE: { // Release statements go here } HOLD[TIME, [REPEAT]]: { // Hold statements go here } } </pre> <p>See the <i>Button Events</i> on page 74.</p>
CHANNEL_EVENT	<p>Defines a channel event handler. This type of handler is invoked when an output change occurs on the specified device-channel and can only be used in the DEFINE_EVENT section of the program.</p> <pre> CHANNEL[DEVICE,CHANNEL] or CHANNEL[(DEVCHAN [])] { ON: { // Channel ON event handling } OFF: { // Channel OFF event handling } } </pre> <p>DEVICE refers to:</p> <ul style="list-style-type: none"> • Device – a single device number constant. • D:P:S – a constant device specification such as TP:1:0. <p>CHANNEL refers to:</p> <ul style="list-style-type: none"> • Channel – a single channel number constant. <p>DEVCHAN[] refers to a device-channel array.</p>

Event Handler Keywords (Cont.)	
DATA_EVENT	<p>Defines a data event handler. This type of handler processes COMMAND, STRING, ONLINE, OFFLINE and ONERROR events. It can only be used in the DEFINE_EVENT section of the program.</p> <pre>DATA_EVENT[DEVICE] { COMMAND: { // Command processing goes here } STRING: { // String processing goes here } ONLINE: { // OnLine processing goes here } OFFLINE: { // OffLine processing goes here } ONERROR: { // OnError processing goes here } STANDBY: { // Standby processing goes here } AWAKE: { // Awake processing goes here } }</pre> <p>See the <i>Data Events</i> on page 76 for more information.</p>
LEVEL_EVENT	<p>Defines a level event handler and can only be used in the DEFINE_EVENT section of the program. This type of handler is invoked when a level change occurs on the specified device-channel. The level object is available to the level event handler as a local variable.</p> <pre>LEVEL_EVENT[DEVICE,LEVEL] or LEVEL_EVENT{([DEVLEV[]])} { // level event handler }</pre> <p>See the <i>Level Events</i> on page 78 for more information.</p>
REBUILD_EVENT()	<p>This function rebuilds the NetLinx event table for level, channel, button, timeline, and data events.</p> <ul style="list-style-type: none"> • Modifications to variables used in event declarations affect NetLinx event handling when REBUILD_EVENT() is called after the variables are modified. • REBUILD_EVENT() works on a module-by-module basis (i.e. calling the function in one module does not affect the event table of another module). • REBUILD_EVENT() rebuilds the event table for variables modified in the same block of code in which it resides. • With no braces, a REBUILD_EVENT() in DEFINE_START rebuilds event tables that use any variable modified in DEFINE_START, above the REBUILD_EVENT() statement. <p>You can reduce the scope of the REBUILD_EVENT() by delineating a block with braces as shown at the bottom of the following example:</p> <pre>// end // REBUILD_EVENT() rebuilds the event table for variables modified in the same // block of code in which it resides. With no braces, a REBUILD_EVENT() in // DEFINE_START should rebuild the event tables that use any variable modified in // DEFINE_START, above the REBUILD_EVENT() statement. // You can reduce the scope of the REBUILD_EVENT() by delineating a block with // braces: DEFINE_DEVICE dvTP = 10001:1:0 DEFINE_VARIABLE INTEGER X // loop counter INTEGER nBTNS[4000] DEFINE_START FOR (X = 1; X <= 4000; X++) { nBtNs[X] = X } // the braces below enclose a variable update and REBUILD_EVENT statement in a // single block { SET_LENGTH_ARRAY(nBtNs,4000) REBUILD_EVENT() }</pre>

Event Handler Keywords (Cont.)

REBUILD_EVENT()

(Cont.)

```

BUTTON_EVENT[dvTP,nBtns]
{
  PUSH:
  {
    // ...
  }
}
// end

```

The code below demonstrates how to use the NetLinx REBUILD_EVENT(). function:

```

DEFINE_DEVICE
dvApoc1 = 128:1:0
dvApoc2 = 1505:1:0
dvApoc3 = 1303:1:0
(*-----*)
(* CONSTANT DEFINITIONS GO BELOW *)
(*-----*)
DEFINE_CONSTANT
DEV_panel[] = {dvApoc1,dvApoc2}
(*-----*)
(* DEFINE TYPE DEFINITIONS GO BELOW *)
(*-----*)
DEFINE_TYPE
(*-----*)
(* VARIABLE DEFINITIONS GO BELOW *)
(*-----*)
DEFINE_VARIABLE
DEV_curModApoc
(*-----*)
(* EVENT DEFINITIONS GO BELOW *)
(*-----*)
DEFINE_EVENT
BUTTON_EVENT[panel,1]
{
  PUSH:
  {
    ON[panel,1]
    curModApoc = dvApoc2
    // updates program event table to handle BUTTON_EVENT[1505:1:0,5]
    REBUILD_EVENT()
  }
  RELEASE: OFF[panel,1]
}
BUTTON_EVENT[panel,2]
{
  PUSH:
  {
    ON[panel,2]
    curModApoc = dvApoc3
    // updates program event table to handle BUTTON_EVENT[1303:1:0, 5]
    REBUILD_EVENT()
    // the following assignment has no affect on the program event table
    curModApoc = dvApoc1
  }
  RELEASE: OFF[panel,2]
}
BUTTON_EVENT[curModApoc,5]
{
  PUSH: ON[dvApoc3,5]
  RELEASE: OFF[dvApoc3,5]
}

```

File Operation Keywords

NetLinx supports the following File Operation keywords:

File Operation Keywords	
FILE_CLOSE	<p>This function closes a file opened with <code>FILE_OPEN</code>. This function should be called when all reading or writing to the file is completed.</p> <pre>SLONG File_Close (LONG hFile)</pre> <p>Parameters:</p> <ul style="list-style-type: none"> • <code>hFile</code>: Handle to the file returned by <code>FILE_OPEN</code>. <p>Result:</p> <ul style="list-style-type: none"> 0: Operation was successful -1: Invalid file handle -5: Disk I/O error -7: File already closed <p>There is a limit to the number of file handles available from the system. If files are not closed, it may not be possible to open a file.</p> <pre>Result = File_Close(hFile)</pre>
FILE_COPY	<p>This function copies the specified file.</p> <pre>SLONG File_Copy(CHAR SrcFilePath[], CHAR DstFilePath[])</pre> <p>Parameters:</p> <ul style="list-style-type: none"> • <code>SrcFilePath</code>: Path name of the file to copy (source). • <code>DstFilePath</code>: Path name of the copied file (destination). <p>Result:</p> <ul style="list-style-type: none"> 0: Operation was successful -2: Invalid file name -5: Disk I/O error -11: Disk full <p>If either path name fails to specify a directory, the current directory is assumed. The current directory is either the top-level directory or the subdirectory specified in the last call to <code>FILE_SETDIR</code>.</p> <pre>// copy OLDFILE.TXT in the current directory to NEWFILE.TXT Result = File_Copy('OLDFILE.TXT', 'NEWFILE.TXT')</pre> <pre>CHAR Buffer[1024] SLONG NumFiles = 1 LONG Entry = 1 WHILE (NumFiles > 0) { NumFiles = FILE_DIR ('AAA:', Buffer, Entry) Entry = Entry + 1 // add code to display contents of Buffer }</pre>
FILE_CREATEDIR	<p>Creates a specified directory path.</p> <p>Syntax:</p> <pre>SLONG File_CreateDir (CHAR DirPath[])</pre> <p>This function will not create the number of subdirectories needed to complete the directory path if they do not exist. The subdirectories must be created one level at a time.</p> <p>NOTE: <i>The <code>LONG</code> command cannot pass negative numbers, so if you have errors these will never be recognized. <code>SLONG</code> must be assigned or errors will be typecast to positive numbers.</i></p> <p>Parameters:</p> <ul style="list-style-type: none"> • <code>DirPath</code> - string containing the directory path to create. <p>Result:</p> <ul style="list-style-type: none"> 0 = operation was successful -4 = invalid directory path -5 = disk I/O error -13 = directory name exists <p>Example:</p> <pre>File_CreateDir('\CDLIST\') File_CreateDir('\CDLIST\TEMP\')</pre> <p>Creates both <code>\CDLIST</code> and <code>\CDLIST\TEMP</code> subdirectories.</p>

File Operation Keywords (Cont.)	
FILE_DELETE	<p>This function deletes a specified file.</p> <pre>SLONG FILE_DELETE (CHAR FilePath[])</pre> <p>Parameters:</p> <ul style="list-style-type: none"> • FilePath: Path name of the file to delete. <p>NOTE: Wildcard characters (* and ?) are NOT permitted in the path name. You must use actual filenames to avoid a disk I/O error.</p> <p>NOTE: The <i>LONG</i> command cannot pass negative numbers, so if you have errors these will never be recognized. <i>SLONG</i> must be assigned or errors will be typecast to positive numbers.</p> <p>Result:</p> <ul style="list-style-type: none"> 0: Operation was successful -2: Invalid file path or name -5: Disk I/O error <pre>// delete 'myFile.txt' in the directory \CDLIST\TEMP\ Result = FILE_DELETE('\CDLIST\TEMP\myFile.txt')</pre>
FILE_DIR	<p>This function returns a list of files located at the specified path. The syntax:</p> <pre>SLONG FILE_DIR (CHAR DirPath[], CHAR Buffer[], LONG Entry)</pre> <p>Parameters:</p> <ul style="list-style-type: none"> • DirPath: String containing the path to the requested directory. • Buffer: Buffer to hold the directory list. • Entry: Requested directory entry. <p>This function returns the number of remaining files in the directory, or:</p> <ul style="list-style-type: none"> -4: Invalid directory path -5: Disk I/O error -6: Invalid parameter (i.e. Entry points beyond the end of the directory, or is 0) -10: Buffer too small -12: Directory not loaded <p>NOTE: Each directory entry will have a <CR><LF> character pair appended to the end.</p> <p>NOTE: The <i>LONG</i> command cannot pass negative numbers, so if you have errors these will never be recognized. <i>SLONG</i> must be assigned or errors will be typecast to positive numbers.</p> <p>Example:</p> <pre>CHAR Buffer[1024] LONG NumFiles = 1 LONG Entry = 1 WHILE (NumFiles > 0) { NumFiles = FILE_DIR ('CDLIST', Buffer, Entry) Entry = Entry + 1 // add code to display contents of Buffer }</pre>
FILE_GETDIR	<p>This function returns the current working directory.</p> <pre>SLONG FILE_GETDIR (CHAR DirPath[])</pre> <p>Parameters:</p> <ul style="list-style-type: none"> • DirPath: Buffer to receive the current working directory. <p>Result:</p> <ul style="list-style-type: none"> 0: Operation was successful -10: Size of DirPath buffer insufficient to hold directory path name <pre>CHAR Buffer[256]Result = FILE_GETDIR (Buffer)</pre>
FILE_OPEN	<p>This function opens a file for reading or writing.</p> <pre>SLONG FILE_OPEN (CHAR FilePath[], LONG IOFlag)</pre> <p>Parameters:</p> <ul style="list-style-type: none"> • FilePath: String containing the path to the file to be opened • IOFlag: <ol style="list-style-type: none"> 1 <i>Read:</i> The file is opened with READ ONLY status. The constant <code>FILE_READ_ONLY</code> is defined as a value of 1 for specifying this flag. 2 <i>R/W New:</i> The file is opened with READ WRITE status. If the file currently exists, its contents are erased. The constant <code>FILE_RW_NEW</code> is defined as a value of 2 for specifying this flag. 3 <i>R/W Append:</i> The file is opened with READ WRITE status. The current contents of the file are preserved and the file pointer is set to point to the end of the file. The constant <code>FILE_RW_APPEND</code> is defined as a value of 3 for specifying this flag. <p>If the open operation is successful, this function returns a non-zero integer value representing the handle to the file. This handle must be used in subsequent read, write, and close operations.</p> <ul style="list-style-type: none"> >0: Handle to file (open was successful) -2: Invalid file path or name -3: Invalid value supplied for IOFlag -5: Disk I/O error -14: Maximum number of files are already open (max is 10) -15: Invalid file format <p>If the file is opened successfully, it must be closed after all reading or writing is completed, by calling <code>FILE_CLOSE</code>. If files are not closed, subsequent file open operations may fail due to the limited number of file handles available.</p> <pre>// Open MYFILE.TXT for reading hFile = FILE_OPEN('MYFILE.TXT', FILE_READ_ONLY)</pre>

File Operation Keywords (Cont.)	
FILE_READ	<p>This function reads a block of data from the specified file.</p> <pre>SLONG FILE_READ (LONG hFile, CHAR Buffer[], LONG BufLen)</pre> <p>Parameters:</p> <ul style="list-style-type: none"> • hFile: Handle to the file returned by FILE_OPEN • Buffer: Buffer to hold the data to be read • BufLen: Maximum number of bytes to read <p>Result:</p> <ul style="list-style-type: none"> >0: The number of bytes actually read -1: Invalid file handle -5: Disk I/O error -6: Invalid parameter -9: End-of-file reached <p>This function reads (from the current location of the file pointer) the number of bytes specified by BufLen (or fewer bytes if the end of file is reached). The bytes are read from the file identified by hFile and are stored in Buffer. The file pointer will automatically be advanced the correct number of bytes so the next read operation continues where the last operation left off.</p> <pre>CHAR Buffer[1024]nBytes = FILE_READ (hFile, Buffer, 1024)</pre>
FILE_READ_LINE	<p>This function reads a line of data from the specified file.</p> <pre>SLONG FILE_READ_LINE (LONG hFile, CHAR Buffer[], LONG BufLen)</pre> <p>Parameters:</p> <ul style="list-style-type: none"> • hFile: Handle to the file returned by FILE_OPEN • Buffer: Buffer to hold the data to be read • BufLen: Maximum number of bytes to read <p>Result:</p> <ul style="list-style-type: none"> =0: The number of bytes actually read -1: Invalid file handle -5: Disk I/O error -6: Invalid parameter (buffer length must be greater than zero) -9: End-of-file reached <p>This function reads from the current location of the file pointer up to the next carriage return or to the end-of-file (EOF), whichever comes first. A complete line will not be read if the buffer length is exceeded before a carriage return (or EOF) is encountered. The bytes are read from the file identified by hFile and are stored in Buffer. The <CR> or <CR><LF> pair will not be stored in Buffer. If a complete line is read, the file pointer is advanced to the next character in the file after the <CR> or <CR><LF> pair or to the EOF if the last line was read.</p> <pre>CHAR Buffer[80]nBytes = FILE_READ_LINE (hFile, Buffer, 80)</pre>
FILE_REMOVEDIR	<p>This function removes the specified directory path (including subdirectories), only if it is empty. If any files are present in the directory path, the function will not work. If any file(s) exist in the directory that you are trying to remove, the operation will return a -5 (disk IO error).</p> <pre>SLONG FILE_REMOVEDIR (CHAR DirPath[])</pre> <p>Parameters:</p> <ul style="list-style-type: none"> • DirPath: String containing the directory path to remove. <p>Result:</p> <ul style="list-style-type: none"> 0: Operation was successful -4: Invalid directory path -5: Disk I/O error <p>Example:</p> <p>The following code will delete the \CDLIST\TEMP directory, assuming that there are no files or subdirectories present:</p> <pre>FILE_REMOVEDIR ('\CDLIST\TEMP')</pre>
FILE_RENAME	<p>This function renames the specified file.</p> <pre>SLONG FILE_RENAME (CHAR FilePath[], CHAR NewFileName[])</pre> <p>Parameters:</p> <ul style="list-style-type: none"> • FilePath: Path name of the file to rename. • NewFileName: New file name. This name must not contain a directory path. <p>Result:</p> <ul style="list-style-type: none"> 0: Operation was successful -2: Invalid file name -5: Disk I/O error -8: File name exists <pre>// renames \CDLIST\OLDFILE.TXT to \CDLIST\NEWFILE.TXT Result = FILE_RENAME ('\CDLIST\OLDFILE.TXT', 'NEWFILE.TXT')</pre>

File Operation Keywords (Cont.)	
FILE_SEEK	<p>This function sets the file pointer to the specified position.</p> <pre>SLONG FILE_SEEK (LONG hFile, LONG Pos)</pre> <p>Parameters:</p> <ul style="list-style-type: none"> • hFile: Handle to the file returned by FILE_OPEN. • Pos: The byte position to set the file pointer (0 = beginning of file, -1 = end of file). <p>Result:</p> <ul style="list-style-type: none"> >=0: Operation was successful and the result is the current file pointer value -1: Invalid file handle -5: Disk I/O error -6: Invalid parameter; pos points beyond the end-of-file (position is set to the end-of-file) <p>After FILE_SEEK is successfully called, subsequent read or write operations begin at the byte number specified by Pos.</p> <pre>// Sets the file pointer to byte number 1000. Subsequent // read or write operations will begin at byte number 1000. Result = FILE_SEEK (hFile, 1000)</pre>
FILE_SETDIR	<p>This function sets the current working directory to the specified path.</p> <pre>SLONG FILE_SETDIR (CHAR DirPath[])</pre> <p>Parameters:</p> <ul style="list-style-type: none"> • DirPath: String containing the directory path. <p>Result:</p> <ul style="list-style-type: none"> 0: Operation successful -4: Invalid directory path -5: Disk I/O error <pre>Result = FILE_SETDIR ('\\CDLIST\\TEMP\\')</pre>
FILE_WRITE	<p>This function writes a block of data to the specified file.</p> <pre>SLONG FILE_WRITE (LONG hFile, CHAR Buffer[], LONG BufLen)</pre> <p>Parameters:</p> <ul style="list-style-type: none"> • hFile: Handle to the file returned by FILE_OPEN. • Buffer: Buffer containing the data to write. • BufLen: Number of bytes to write. <p>Result:</p> <ul style="list-style-type: none"> >0: The number of bytes actually written -1: Invalid file handle -5: Disk I/O error -6: Invalid parameter (buffer length must be greater than zero) -11: Disk full <p>The data will overwrite or append to the current contents of the file depending on the current position of the file pointer.</p> <pre>CHAR Buffer[1024]Result = FILE_WRITE (hFile, Buffer, 1024)</pre>
FILE_WRITE_LINE	<p>This function writes a line of data to the specified file.</p> <pre>SLONG FILE_WRITE_LINE (LONG hFile, CHAR Line[], LONG LineLen)</pre> <p>Parameters:</p> <ul style="list-style-type: none"> • hFile: Handle to the file returned by FILE_OPEN. • Line: Buffer containing the line of data to write. • LineLen: Number of bytes to write. <p>Result:</p> <ul style="list-style-type: none"> >0: The number of bytes actually written -1: Invalid file handle -5: Disk I/O error -6: Invalid parameter (LineLen must be greater than zero) -11: Disk full <p>NOTE: A <CR><LF> character pair is automatically appended to the end of the line.</p> <pre>CHAR Line[80]Result = FILE_WRITE_LINE (hFile, Line, 80)</pre> <p>NOTE: The <i>LONG</i> command cannot pass negative numbers, so if you have errors these will never be recognized. <i>SLONG</i> must be assigned or errors will be typecast to positive numbers.</p>

Get Keywords

NetLinx supports the following GET keywords:

GET Keywords	
GET_AVAILABLE_FLASH_DISK_SPACE	This function returns the number of bytes of flash disk space available. Syntax: <code>long GET_AVAILABLE_FLASH_DISK_SPACE()</code>
GET_DNS_LIST	See page 96.
GET_IP_ADDRESS	See page 97.
GET_LAST	This function returns the index of the array element that most recently caused an event handler to be triggered. <pre> DEFINE_VARIABLE DEVCHAN dcMyDCSet[] = { {TP,5}, {TP,4}, {TP,3}, {TP,2}, {TP,1}} INTEGER Index BUTTON_EVENT[dcMyDCSet] { PUSH: { Index = GET_LAST(dcMyDCSet) Switch (Index) { Case 1: {} (* Button 5 was pressed *) Case 2: {} (* Button 4 was pressed *) Case 3: {} (* Button 3 was pressed *) Case 4: {} (* Button 2 was pressed *) Case 5: {} (* Button 1 was pressed *) } } } </pre> <p>Result:</p> <ul style="list-style-type: none"> • 0: No Event was triggered using this array. • >0: The index that causes an event to be triggered. <p>Since the <code>PUSH</code> and <code>RELEASE</code> keywords can be written using <code>DEVCHAN</code> arrays, this function can also be used to determine which element causes a push or release to be triggered. The function can be called anywhere in code but is usually called from within an event handler. A classic application of this function is to determine the keypad number pressed when the channel codes for the keypad are out of order, which they typically are for a wireless transmitter.</p>
GET_MAX_FLASH_DISK_SPACE	This function returns the maximum number of bytes of flash disk space available. Syntax: <code>long GET_MAX_FLASH_DISK_SPACE()</code>
GET_PULSE_TIME	This keyword returns the current duration of <code>PULSE</code> and <code>MINTO</code> commands as set by <code>SET_PULSE_TIME</code> . Time is measured in tenths of a second; the default is 5 (0.5 seconds). <code>PulseTime = GET_PULSE_TIME</code>
GET_SERIAL_NUMBER	This function returns the 16-character serial number of the specified device. The serial number of every device is established when manufactured. NOTE: <i>GET_SERIAL_NUMBER only returns the serial number of the local master, not other masters or devices.</i> NOTE: <i>The LONG command cannot pass negative numbers, so if you have errors these will never be recognized. SLONG must be assigned or errors will be typecast to positive numbers.</i> <pre> SLONG GET_SERIAL_NUMBER(DEV Device,CHAR SerialNumber[]) </pre> <p>Parameters:</p> <ul style="list-style-type: none"> • Device: Device from which the serial number will be retrieved. • SerialNumber: String that will receive the device's serial number. <p>Result:</p> <ul style="list-style-type: none"> • 0: Operation was successful • -1: Specified device is invalid or is not online <pre> Result = GET_SERIAL_NUMBER(128:1:0,serialNum) </pre>
GET_SYSTEM_NUMBER	This function returns the system number of the NetLinx Master. <pre> INTEGER GET_SYSTEM_NUMBER() </pre> <p>The result is an integer representing the system number of the NetLinx Master.</p> <pre> SystemNum = GET_SYSTEM_NUMBER() // get local system num </pre> <p>NOTE: <i>When it is a NetLinx function the () are NOT OPTIONAL even if there are no parameters.</i></p>
GET_TIMER	This keyword returns an unsigned long integer representing the value currently held by the system timer. <ul style="list-style-type: none"> • Time is measured in tenths of a second. • The system timer is set to zero on power-up. <pre> SystemTime = GET_TIMER </pre>

GET Keywords (Cont.)	
GET_UNIQUE_ID	<p>This function returns a 48-bit hardware constant guaranteed to be unique in the domain of NetLinx Masters. Possible uses for GET_UNIQUE_ID include identification of a particular system for the purpose of providing system specific capability or limiting the functionality of a NetLinx program to operate on a specific master.</p> <pre>CHAR[6] GET_UNIQUE_ID ()</pre> <p>The result is a 48-bit constant returned as a 6-element character array.</p> <pre>SYSID = GET_UNIQUE_ID() // get the master's h/w ID IF(SYSID = "\$00,\$01,\$09,\$73,\$25,\$01") { // allow system to operate normally }</pre>
GET_URL_LIST	<p>This function returns a list of URLs that the specified device is programmed to actively attempt to connect to. The function requires an array of URL_STRUCT Structures that will get filled in with the device's URL list.</p> <pre>SLONG Get_URL_List(DEV Device,URL_STRUCT UrlList[],INTEGER Type)</pre> <p>Parameters:</p> <ul style="list-style-type: none"> • Device: Device number of the device from which the URLs will be retrieved. Typically, they are stored on the local master (0:1:0), but if you are currently connected to another master you can use <0:1:system number of remote master>. • UrlList: Array of URL_STRUCTS that will receive the device's URLs • Type: Indicates the type(s) of URLs desired-NetLinx language programmed, IDE programmed, or both <ol style="list-style-type: none"> 1: All URLs 2: NetLinx programmed URLs 3: IDE programmed URLs <p>The function returns the number of URLs updated in the supplied array of URL_STRUCTS.</p> <p>-1: Specified device is invalid or is not online -2: Request timed out -3: Busy</p> <p>URLs may be programmed by either the Integrated Development environment or via the ADD_URL_ENTRY function. The Type parameter filters the list of URLs so that only the desired URLs are returned in the URL_STRUCT(s). The function requires an array of URL_STRUCTS.</p> <p>The URL_STRUCT is predefined as follows:</p> <pre>STRUCTURE URL_STRUCT { CHAR Flags; // Connection Type (normally 1) INTEGER Port; // TCP port (normally 1319) CHAR URL[128]; // string: URL or IP address CHAR User[20]; // optional account info for ICSPS CHAR Password[20]; // optional account info for ICSPS }</pre> <p>The following definitions exist for the Flags member of the URL_STRUCT structure.</p> <pre>CONSTANT CHAR URL_Flg_TCP = 1 // TCP connection CONSTANT CHAR URL_Flg_TEMP = \$10 CONSTANT CHAR URL_Flg_Stat_PrgNetLinx = \$20 // URL set by // NetLinx // ADD_URL_ENTRY CONSTANT CHAR URL_Flg_Stat_Mask = \$C0 // status mask CONSTANT CHAR URL_Flg_Stat_Lookup = \$00 // Looking up IP CONSTANT CHAR URL_Flg_Stat_Connecting = \$40 // connecting CONSTANT CHAR URL_Flg_Stat_Waiting = \$80 // waiting CONSTANT CHAR URL_Flg_Stat_Connected = \$C0 // connected</pre> <p>See GET_URL_LIST Flags Member Bit Fields below.</p> <p>Example:</p> <pre>URL_STRUCT UrlList [10] Result = GET_URL_LIST(0:0:0,UrlList,0) (* Get ALL URLs *) -or- Result = GET_URL_LIST(0:0:0,UrlList,1) (* Get NetLinx-programmed URLs *) -or- Result = GET_URL_LIST(0:0:0,UrlList,2) (* Get IDE-programmed URLs *)</pre> <p>NOTE: There is a known issue with this function: If you have only 1 URL entry, it will return nothing. If you have 2 entries, it will return the second entry.</p>

GET_URL_LIST Flags Member Bit Fields

The Flags member is a bit field that is used for several different purposes. Each bit is defined in the table below:

GET_URL_LIST Flags Member Bit Fields			
Bit	Mathematical Value	Normal value	Meaning
Bit 0	1 (0x01)	1	0 = Establishes a UDP connection. 1 = Establishes a TCP connection.
Bit 1	2 (0x02)	0	Unused
Bit 2	4 (0x04)	0	Unused
Bit 3	8 (0x08)	0	Unused
Bit 4	16 (0x10)	0	Establishes a Temp Connection. A Temp Connection is one that is set, but is not stored in flash, and therefore is not restored when the master reboots. If the NetLinx code is adding URL entries, it is recommended to make them temporary so that the flash is not constantly being written, especially since the code handles all the connections anyway.
Bit 5	32 (0x20)	0	Source of URL. 0 = Programmed by the IDE. 1 = Programmed by NetLinx <code>ADD_URL_ENTRY</code> .
Bit 6 Bit 7	64 (0x40) 128 (0x80)	0	Encoded status indication (Read only). These 2 bits together form one of 4 possible codes indicating the status of the connection. <ul style="list-style-type: none"> • 0x00 - Looking up IP address or URL. • 0x40 - Connecting to URL. • 0x80 - Waiting for connection to establish. • 0xC0 - Connected.

IP Keywords

Overview - IP Communication

Clients and servers communicate via Internet Protocol (IP) using either a connection-oriented or connection-less protocol. Connection-oriented input/output (I/O) channels require a connection or virtual circuit to be established between the client and server before data can be transmitted or received. Transmission Control Protocol (TCP) is the transport protocol typically used for connection-oriented I/O. With TCP, delivery of the data is guaranteed.

With connection-less I/O, a connection is not established between the client and server before data is exchanged. Instead, the identity of the client and server is established each time data is sent or received. This type of communication is usually recommended for applications that transfer only small amounts of data. User Datagram Protocol (UDP) is the transport protocol used for connection-less I/O. With UDP, delivery of the data is not guaranteed. Both the client and server must be able to identify incoming and outgoing data for a particular conversation. To achieve this, each application assigns a unique number to the conversation. This number is the local port number. A local port is not a physical port but rather a virtual port that identifies the source or destination for data exchanged during the conversation. Local ports are specific to either the client or the server; they need not match across applications.

The application assigns the number for the local port - as opposed to letting the system assign it (for instance, as the return value for `IP_CLIENT_OPEN` or `IP_SERVER_OPEN`) - to satisfy the static nature of `DEFINE_EVENT` handlers. All event handlers must specify a device, port, and system to identify the events' source. This device information must be constant; that is, it cannot change at run-time. A constant IP device specification can be defined using a local port number.

For example:

```
Device Number = 0      The master
Port = LocalPort      The local port number
System = 0            This system (where the application is running)
```

A range of numbers is reserved for local port numbers to make sure that this IP device-naming convention does not interfere with future naming schemes. The program can only assign local port numbers at or above the value of the keyword, `FIRST_LOCAL_PORT`. All port numbers below `FIRST_LOCAL_PORT` are reserved for future use.

For example:

```
DEFINE_CONSTANT
PORT_REMOTE_MASTER1 = FIRST_LOCAL_PORT
PORT_REMOTE_MASTER2 = FIRST_LOCAL_PORT + 1
PORT_REMOTE_MASTER3 = FIRST_LOCAL_PORT + 2
```

Client Programming

Initiating a conversation

To initiate a conversation with a server, the client must use the `IP_CLIENT_OPEN` command and supply either the IP address or domain name of the server and a port number for the requested service. The client must also specify a local port number to use for sending and receiving data. This number represents a virtual port on the client machine; it is not the actual port number used to create the client-end socket. A local port number may not be used in another call to `IP_CLIENT_OPEN` until `IP_CLIENT_CLOSE` is called for that port number.

The syntax is shown below:

```
IP_Client_Open(LocalPort, ServerAddress, ServerPort, Protocol)
```

Parameters:

- **LocalPort:** A user-defined, non-zero integer value representing the virtual port on the client machine that will be used for this conversation. This port number must be passed to `IP_CLIENT_CLOSE` to close the conversation.
- **ServerAddress:** A string containing either the IP address (in dotted-quad-notation) or the domain name of the server to connect to.
- **ServerPort:** The port number on the server that identifies the program or service the client is requesting.
- **Protocol:** The transport protocol to use (1 = TCP, 2 = UDP). If this parameter is not specified, TCP (1) is assumed. The constants `IP_TCP` and `IP_UDP` can be used to specify this parameter.

Terminating a conversation

To terminate a conversation, you must use the `IP_CLIENT_CLOSE` command and pass the number of the local port used for the conversation.

The syntax:

```
IP_Client_Close(LocalPort)
```

Parameters:

- **LocalPort:** A user-defined, non-zero integer value representing the virtual port on the client machine that will be used for this conversation.

Sending data

To send data to the server, use the `SEND_STRING` command.

```
SEND_STRING 0:LocalPort:0, '<string>'
```

The device specification (`0:LocalPort:0`) is interpreted as follows:

- Device Number: 0: The master
- Port: LocalPort: The local port number
- System: 0: This system (the client)

Receiving data

To receive data from the server, use a `DATA` event handler or a buffer created with `CREATE_BUFFER` or `CREATE_MULTI_BUFFER`. If an event handler is used, the data is located in the `Text` field of the `DATA` object. The syntax is shown below:

```
Data_Event[Device]
{
  STRING:
  {
    // process incoming string (Data.Text)
  }
}
```

Parameters:

- `Device` is (or contains as part of an array) the device representing the conversation (`0:LocalPort:0`)

When using IP sockets in NetLinx, it is not uncommon to create a buffer using a `CREATE_BUFFER` keyword and processing the buffer in the `DATA_EVENT...OFFLINE` event. NetLinx has an important behavior that can affect the performance of IP socket code. This is not a bug but a feature. If you are aware of it, you can write your code to take maximum advantage of the speed NetLinx offers. When processing string data from a device, whether it is a regular device or an IP socket, the master will attempt to copy this data to a buffer, if one has been created using the `CREATE_BUFFER` keyword, and then try to run a `DATA_EVENT...STRING` handler for this device.

If a `DATA_EVENT...STRING` handler does not exist, NetLinx will run mainline to allow for any buffer processing that might occur in mainline. At the end of a conversation with an IP device, there will usually be an incoming string event followed by an offline event. The NetLinx master will copy the string to a buffer, if it exists, check for a string event handler, run mainline if one does not exist, then process the offline event.

If you are processing that data in an offline event for an IP device, you will see a time delay between the IP device or server closing the connection and the processing of the offline event. This delay will vary with the size and complexity of mainline. To eliminate this delay, simply include an empty string event handler in the `DATA_EVENT` section. This will keep NetLinx from running mainline between the last incoming string and the offline event. See this example:

```
DATA_EVENT[dvIP]
{
  OFFLINE:
  {
    (* PROCESS THE DATA HERE*)
  }

  STRING:
  {
    (* DO NOT REMOVE ME! *)
  }
}
```

Server Programming

Listening for client requests

A client gains access to a service by sending a request to the server specifying the port assigned to the service. For the request to be acknowledged, the server must be listening on that port. To do this, the server calls `IP_SERVER_OPEN`. This opens the port and allows the server to listen for requests from client applications. `IP_SERVER_OPEN` requires the caller to supply a local port number. This local port number is a virtual port, as opposed to an actual physical port on the server.

- When TCP is the transport protocol, the local port represents a single client connection on the server's physical port.
- When UDP is the transport protocol, it represents a single point where all client requests on the associated port are routed.

The local port number is the key to identifying data sent to or received from a client application. A local port number may not be used in another call to `IP_SERVER_OPEN`, until `IP_SERVER_CLOSE` is called for that port number.

The syntax:

```
IP_SERVER_OPEN(LocalPort, ServerPort, Protocol)
```

Parameters:

- **LocalPort:** The local port number to open. This port number must be passed to `IP_CLIENT_CLOSE` to close the conversation.
- **ServerPort:** The port number on the server identifies the program or service the client is requesting.
- **Protocol:** The transport protocol to use (1 = TCP, 2 = UDP). If this parameter is not specified, TCP (1) is assumed. The constants `IP_TCP` and `IP_UDP` can be used to specify this parameter.

Multiple client connections

With connection-oriented I/O (TCP), more than one client could request a connection with the server at the same time. Support for multiple client connections applies only to connection-oriented I/O, that is, TCP protocol. Opening multiple ports using UDP as the protocol serves no purpose. In that case, any additional open commands will fail.

To support concurrent requests, the server must call `IP_SERVER_OPEN` once for each simultaneous connection allowed. For example:

```
IP_SERVER_OPEN (First_Local_Port, 10510, IP_TCP)
IP_SERVER_OPEN (First_Local_Port, 10510, IP_TCP)
IP_SERVER_OPEN (First_Local_Port, 10510, IP_TCP)
```

This allows three simultaneous connections on port 10510. Note that each call to `IP_SERVER_OPEN` uses a different local port number.

Closing a local port

To close a local port, the server application must call `IP_SERVER_CLOSE`. Once that is called, no I/O can be handled using the specified local port. The syntax:

```
IP_SERVER_CLOSE(LocalPort)
```

Parameters:

- **LocalPort:** The local port number to close.

Connection-Oriented notifications

The server receives the following notifications when a client connects or disconnects.

The protocol in this case must be TCP.

```
DATA[0:LocalPort:0]
{
    ONLINE:
    {
        // client has connected
    }
    OFFLINE:
    {
        // client has disconnected
    }
}
```

Parameters:

- Device is (or contains as part of an array) the device representing the conversation (0:LocalPort:0).

Receiving data

To receive data from a client, use a `DATA` event handler or a buffer created with `CREATE_BUFFER` or `CREATE_MULTI_BUFFER`. If an event handler is used, the data is located in the `Text` field of the `DATA` object.

The syntax:

```
Data_Event[Device]
{
    STRING:
    {
        // process incoming string (Data.Text)
    }
}
```

Parameters:

- Device is (or contains as part of an array) the device representing the conversation (0:LocalPort:0).

Sending data

To send data to the client, use the SEND_STRING command.

```
SEND_STRING 0:LocalPort:0, '<string>'
```

The device specification (0:LocalPort:0) is interpreted as follows:

- Device Number: 0: The master
- Port: LocalPort: The local port number
- System: 0: This system (the client)

Receiving Data with UDP

Since UDP is connection-less, no formal agreement has been made between the client and server to exchange data. The client simply sends a UDP message and hopes the server is listening. In many protocols that use UDP for communication, there is an implied agreement for the client to receive data from the server. When a UDP client socket is created, the socket is assigned a UDP/IP port number, not to be confused with local port. This UDP/IP port will be used to send UDP messages. The server, if listening, will receive this message along with the IP address and UDP/IP of the client who sent the message.

Some UDP protocols have an implied agreement that the server will be able to respond to the client by sending a response back to the IP address and UDP/IP from where the message originated. Although the UDP protocol does not specify that the client must expect to receive messages in this way, many UDP/IP require the client to listening for response after sending a message.

NetLinx has two UDP client implementations. These are **UDP (2)** and **UDP With Receive (3)**.

- **UDP** only sends message and cannot receive messages.
- **UDP with Receive** will send and receive messages on a single UDP/IP port.

It may seem like UDP (2) is not needed; however, it still serves an important purpose. Imagine you wanted to send a UDP message and expect a response. The proper way to open this type of socket, assuming you want to send a UDP message to 192.168.0.1 on UDP/IP port 6000, is:

```
IP_CLIENT_OPEN (dvUDPClient, '192.168.0.1', 6000, IP_UDP_2WAY)
```

Now, if you were also writing the code for 192.168.0.1, you would need to have opened a UDP server using the following:

```
IP_SERVER_OPEN (dvUDPServer, 6000, IP_UDP)
```

When the message is received at 192.168.0.1, the message will be delivered to the DATA_EVENT for dvUDPServer and the IP address UDP/IP port of the sender of the message will be available in the DATA.SOURCEIP and DATA.SOURCEPORT variables. A UDP (2) socket would be used in this case to send a response to the client. Since we will no longer need to listen after sending the response, since there would be no response to the response, we would open the socket using the following:

```
IP_CLIENT_OPEN (dvUDPClient, DATA.SOURCEIP, DATA.SOURCEPORT, IP_UDP)
```

Note that UDP with Receive (3) is only available when calling IP_CLIENT_OPEN.

Multicast

NetLinx can send and receive multi-cast UDP messages. To send a multi-cast UDP message, all you need to do is specify a multi-cast address and port in the IP_CLIENT_OPEN function such as the following:

```
IP_CLIENT_OPEN (dvIPClient.Port, '239.255.255.250', 1900, IP_UDP)
```

To receive multi-cast UDP messages, you must call the IP_MC_SERVER_OPEN function:

```
IP_MC_SERVER_OPEN (dvIPServer, '239.255.255.250', 1900)
```

The NetLinx master will join the multi-cast session and allow you to receive and transmit UDP multi-cast messages.

Example IP Code

```
PROGRAM_NAME='IPEXample'
(*****
(*          DEVICE NUMBER DEFINITIONS GO BELOW          *)
(*****
DEFINE_DEVICE
dvIPServer  = 0:2:0
dvIPClient  = 0:3:0
(*****
(*          CONSTANT DEFINITIONS GO BELOW          *)
(*****
DEFINE_CONSTANT

nIPPort     = 8000
(*****
(*          VARIABLE DEFINITIONS GO BELOW          *)
(*****
DEFINE_VARIABLE

IP_ADDRESS_STRUCT MyIPAddress  (* .Flags          *)
                               (* .HostName         *)
                               (* .IPAddress        *)
                               (* .SubnetMask         *)
                               (* .Gateway          *)
```

```

(*****)
(*          STARTUP CODE GOES BELOW          *)
(*****)

DEFINE_START
(* Get My IP Address *)
GET_IP_ADDRESS(0:0:0,MyIPAddress)
(* Open The Server *)
IP_SERVER_OPEN(dvIPServer.Port,nIPPort,IP_TCP)
(* Open The Client *)
IP_CLIENT_OPEN(dvIPClient.Port,MyIPAddress.IPAddress,nIPPort,IP_TCP)

(*****)
(*          THE EVENTS GO BELOW          *)
(*****)

DEFINE_EVENT
(* Server Data Handler *)
DATA_EVENT[dvIPServer]
{
    ONERROR:
    {
        SEND_STRING 0,"'error: server=',ITOA(Data.Number)"
    }

    ONLINE:
    {
        SEND_STRING 0,"'online: server'"
    }

    OFFLINE:
    {
        SEND_STRING 0,"'offline: server'"
    }

    STRING:
    {
        SEND_STRING 0,"'string: client=',Data.Text"
        IF (FIND_STRING(Data.Text,'ping',1))
            SEND_STRING 0:2:0,"'pong',13"
    }
}

(* Client Data Handler *)
DATA_EVENT[dvIPClient]
{
    ONERROR:
    {
        SEND_STRING 0,"'error: client=',ITOA(Data.Number)"
    }

    ONLINE:
    {
        SEND_STRING 0,"'online: client'"
    }

    OFFLINE:
    {
        SEND_STRING 0,"'offline: client'"
    }

    STRING:
    {
        SEND_STRING 0,"'string: client=',Data.Text"
    }
}

(*****)
(*          THE ACTUAL PROGRAM GOES BELOW          *)
(*****)

DEFINE_PROGRAM
(* Send Ping To Server *)
WAIT 50
    SEND_STRING dvIPClient,"'ping',13"

(*****)
(*          END OF PROGRAM          *)
(*          DO NOT PUT ANY CODE BELOW THIS COMMENT          *)
(*****)

```

IP Keywords

NetLinx supports the following IP keywords:

IP Keywords	
ADD_URL_ENTRY	<p>This function adds a URL entry to the specified device. This function requires a pre-initialized URL_STRUCT that will be sent to the specified device.</p> <pre>SLONG ADD_URL_ENTRY (DEV Device, URL_STRUCT Url)</pre> <p>Parameters:</p> <ul style="list-style-type: none"> • Device: Device number of the device that stores the URL. Typically, it is stored on the local master (0:1:0); If you are currently connected to another master, you can use <0:1:system number of remote master>. • Url: URL_STRUCT that will be programmed into the device. <p>Result:</p> <ul style="list-style-type: none"> • 0: Success • -1: Specified device is invalid or is not online • -2: Time out occurred • -3: Function is already actively adding a URL entry (i.e. busy) • -4: Add failed <p>Note that NetLinx will automatically set bit 5 of the Flags member of the URL_STRUCT structure. See the <i>ADD_URL_ENTRY Flags Member Bit Fields</i> section on page 102 for details.</p>
DELETE_URL_ENTRY	<p>This function deletes a URL entry to the specified device. This function requires a pre-initialized URL_STRUCT that will be sent to the specified device.</p> <pre>SLONG DELETE_URL_ENTRY (DEV Device, URL_STRUCT Url)</pre> <p>Parameters:</p> <ul style="list-style-type: none"> • Device: Device to which the URL will be sent. • Url: URL_STRUCT that will be programmed into the device. <p>Result:</p> <ul style="list-style-type: none"> • 0: Success • -1: Specified device is invalid or is not online • -2: Time out occurred • -3: Function is already actively deleting a URL entry (i.e. busy) • -4: Delete failed <p>See the <i>ADD_URL_ENTRY Flags Member Bit Fields</i> section on page 102 for details.</p>
GET_DNS_LIST	<p>This function returns the domain name and list of DNS server IP addresses that the specified device is programmed to utilize. The order of the returned list is the preferred server order.</p> <pre>DNS_STRUCT DnsListresult = GET_DNS_LIST(0:0:0,DnsList) SLONG GET_DNS_LIST(DEV Device,DNS_STRUCT DnsList)</pre> <p>Parameters:</p> <ul style="list-style-type: none"> • Device: Device from which the DNS servers will be retrieved. • DnsList: A DNS_STRUCT that will receive the device's DNS server list. <p>Result:</p> <ul style="list-style-type: none"> • 0: Operation was not successful • -1: Specified device is invalid or is not online • -2: Request timed out • -3: Busy <p>The function requires a DNS_STRUCT. The DNS_STRUCT is predefined as follows:</p> <pre>STRUCTURE DNS_STRUCT { CHAR DomainName[68] // domain suffix (e.g. amx.com) CHAR DNS1[15] // IP address of 1st DNS server CHAR DNS2[15] // IP address of 2nd DNS server CHAR DNS3[15] // IP address of 3rd DNS server }</pre>

GET_IP_ADDRESS	<p>This function returns the TCP/IP configuration of the specified device. The configuration information includes DHCP/Static configuration, IP address, subnet mask, gateway, and host name.</p> <pre>SLONG GET_IP_ADDRESS (DEV Device, IP_ADDRESS_STRUCT IPAddress)</pre> <p>Parameters:</p> <ul style="list-style-type: none"> • Device: Device from which the TCP/IP configuration will be retrieved. • IPAddress: An IP_ADDRESS_STRUCT that will receive the device's TCP/IP configuration. <p>Result:</p> <ul style="list-style-type: none"> • 0: Operation was successful • -1: Specified device is invalid or is not online • -2: Request timed out • -3: Busy <p>The function requires an IP_ADDRESS_STRUCT. The IP_ADDRESS_STRUCT is predefined as follows:</p> <pre>STRUCTURE IP_ADDRESS_STRUCT { CHAR Flags // Configuration flags CHAR HostName[128] // Host name CHAR IPAddress[15] // IP address unit CHAR SubnetMask[15] // subnet mask CHAR Gateway[15] // IP address of gateway }</pre> <p>The following definitions exist for the Flags member of the IP_ADDRESS_STRUCT structure.</p> <pre>CONSTANT CHAR IP_Addr_Flg_DHCP = 1 // Use DHCP</pre> <p>The Flags member is a bit field that may be used for several different purposes. See the <i>GET_IP_ADDRESS Flags Member Bit Fields</i> section on page 102 for details. Differing configuration parameters may be obtained, depending upon the configuration of the network DHCP server. It is possible that the DHCP server will provide the host name, IP address, subnet mask, gateway, and even DNS information. In a minimal configuration, the DHCP server will only supply the IP address and subnet mask.</p> <pre>IP_ADDRESS_STRUCT IPAddressResult = GET_IP_ADDRESS (0:0:0, IPAddress)</pre>
IP_BOUND_CLIENT_OPEN	<p>Opens a port for IP communication with a server using a specific local IP port number. Similar to IP_CLIENT_OPEN, but where IP_CLIENT_OPEN uses the first available local IP Port number, IP_BOUND_CLIENT_OPEN allows the user to specify the local IP port number.</p> <p>The syntax:</p> <pre>SLONG IP_BOUND_CLIENT_OPEN (INTEGER LocalPort, INTEGER LocalIPPort, CHAR ServerAddress[], LONG ServerPort, INTEGER Protocol)</pre> <p>NOTE: <i>The LONG command cannot pass negative numbers, so if you have errors these will never be recognized. SLONG must be assigned or errors will be typecast to positive numbers.</i></p> <p>Parameters:</p> <ul style="list-style-type: none"> • LocalPort - a user-defined (non-zero) integer value representing the local port on the client machine to use for this conversation. This local port number must be passed to IP_CLIENT_CLOSE to close the conversation. • LocalIPPort - a user-defined (non-zero) integer value representing the local IP port number the IP client socket must be bound to. • ServerAddress - a string containing either the IP address (in dotted-quad-notation) or the domain name of the server to connect to. • ServerPort - the port number on the server that identifies the program or service that the client is requesting. • Protocol - The transport protocol to use: <ul style="list-style-type: none"> 1 = TCP 2 = UDP 3 = UDP with Receive If this parameter is not specified, TCP (1) is assumed. The constants IP_TCP, IP_UDP and IP_UDP_2WAY can be used to specify this parameter. <p>Result:</p> <ul style="list-style-type: none"> • This function always returns 0. • Errors are returned via the DATA_EVENT ONERROR method. <p>The following errors may be returned:</p> <ul style="list-style-type: none"> 2: General failure (out of memory) 4: Unknown host 6: Connection refused 7: Connection timed out 8: Unknown connection error 14: Local port already used 16: Too many open sockets 17: Local Port Not Open <p>Example:</p> <pre>IP_BOUND_CLIENT_OPEN (PORT1, 3000, SvAddr, SvPort, IP_TCP)</pre>
IP_CLIENT_CLOSE	<p>This function closes a port opened with IP_CLIENT_OPEN.</p> <pre>IP_CLIENT_CLOSE (INTEGER LocalPort)</pre> <p>Parameters:</p> <ul style="list-style-type: none"> • LocalPort: A non-zero integer value representing the local port on the client machine to close. <p>Result:</p> <ul style="list-style-type: none"> • This function always returns 0. • Errors are returned via the DATA_EVENT ONERROR method. <p>The following error may be returned:</p> <ul style="list-style-type: none"> 9: Already closed
IP Keywords (Cont.)	

<p>IP_CLIENT_OPEN</p>	<p>This function opens a port for IP communication with a server.</p> <pre>SLONG IP_CLIENT_OPEN (INTEGER LocalPort, CHAR ServerAddress[], LONG ServerPort, INTEGER Protocol)</pre> <p>Parameters:</p> <ul style="list-style-type: none"> LocalPort: A user-defined (non-zero) integer value representing the local port on the client machine to use for this conversation. This local port number must be passed to IP_CLIENT_CLOSE to close the conversation. ServerAddress: A string containing either the IP address (in dotted quad-notation) or the domain name of the server to connect to. ServerPort: The port number on the server that identifies the program or service the client is requesting. Protocol: The transport protocol to use: <ul style="list-style-type: none"> 1 = TCP 2 = UDP 3 = UDP with Receive <p>If this parameter is not specified, TCP (1) is assumed. The constants IP_TCP, IP_UDP and IP_UDP_2WAY can be used to specify this parameter.</p> <p>Result:</p> <ul style="list-style-type: none"> This function always returns 0. Errors are returned via the DATA_EVENT ONERROR method. <p>The following errors may be returned:</p> <ul style="list-style-type: none"> 2: General failure (out of memory) - Underlying OS socket call failed, reasons undefined. 4: Unknown Host (IP_CLIENT_OPEN) - The specified host name (ex. 'www.amx.com') or IP address (ex. '192.168.200.75') is not resolvable to a physical host. 6: Connection Refused (IP_CLIENT_OPEN) - The specified host does not have a server socket listening on the requested port and therefore refused the connection. 7: Connection Timed Out (IP_CLIENT_OPEN) - The specified host has not replied to the request to connect within a reasonable time. 8: Unknown connection Error (IP_CLIENT_OPEN) - Some other undefined error has occurred with the connection request. 9: Already Closed (IP_CLIENT_CLOSE/IP_SERVER_CLOSE) - The specified connection has already been closed. 10: Binding Error (IP_SERVER_OPEN) - An error has occurred during the underlying OS "bind" function of a socket to a server port number. Possibly the server port is already being listened on. 11: Listening Error (IP_SERVER_OPEN) - An underlying error has occurred; checking for possible client connects to a server socket. 12: Socket not connected - Tried to send data (string or command) on a TCP socket that is not connected either because the open failed, or the connection has been closed. 13: Send to Socket Unknown- Tried to send data (string or command) on a UDP socket that has failed to open. 14: Local Port already used (IP_CLIENT_OPEN/IP_SERVER_OPEN) - The local TCP client or serve port (D:P:S) is already open for use by an earlier IP_CLIENT_OPEN or IP_SERVER_OPEN 15: UDP socket already listening (IP_SERVER_OPEN) - The local UDP port (D:P:S) is already being listened on. 16: Too many open sockets (IP_CLIENT_OPEN/IP_SERVER_OPEN) - NetLinx enforces a limit on the number of allowed open sockets. The current limit is 200. All requests to open a socket beyond this limit will fail. 17: Local port not open - The specified local port (D:P:S) has never been opened by a IP_CLIENT_OPEN or IP_SERVER_OPEN call. <p>Example:</p> <pre>IP_CLIENT_OPEN(PORT1, SvAddr, SvPort, IP_TCP)</pre>
<p>IP_MC_SERVER_OPEN</p>	<p>This function opens a server port to listen for UDP multicast messages.</p> <pre>SINTEGER IP_MC_SERVER_OPEN(INTEGER LocalPort, CHAR MultiCastIP[], LONG ServerPort)</pre> <p>Parameters:</p> <ul style="list-style-type: none"> LocalPort: The local port number to open. This number must be passed to IP_SERVER_CLOSE to close the port. MultiCastIP: A character string representing the multicast address to receive on in the form of: '239.255.255.250'. ServerPort: The UDP multicast port number to listen on. <p>Result:</p> <ul style="list-style-type: none"> This function always returns 0. Errors are returned via the DATA_EVENT ONERROR method. <p>The following errors may be returned:</p> <ul style="list-style-type: none"> 2: General failure (out of memory) - Underlying OS socket call failed, reasons undefined 10: Binding error - An error has occurred during the underlying OS "bind" function of a socket to a server port number. Possibly the server port is already being listened on. 11: Listening error - An underlying error has occurred checking for possible client connects to a server socket. 14: Local port already used - The local TCP client or serve port (D:P:S) is already open for use by an earlier IP_CLIENT_OPEN or IP_SERVER_OPEN. 15: UDP socket already listening - The local UDP port (D:P:S) is already being listened on. 16: Too many open sockets - NetLinx enforces a limit on the number of allowed open sockets. The current limit is 200. All requests to open a socket beyond this limit will fail. <p>Example:</p> <pre>IP_MC_SERVER_OPEN (PORT1, '239.255.255.250', 1900)</pre>

IP_SERVER_CLOSE	<p>This function closes a port opened with IP_SERVER_OPEN or IP_MC_SERVER_OPEN.</p> <pre>IP_SERVER_CLOSE (INTEGER LocalPort)</pre> <p>Parameters:</p> <ul style="list-style-type: none"> • <i>LocalPort</i>: The number of the local port to close. <p>Result:</p> <ul style="list-style-type: none"> • This function always returns 0. • Errors are returned via the DATA_EVENT_ONERROR method. <p>The following error may be returned:</p> <p>9: Already closed</p> <p>Example:</p> <pre>IP_Server_Close(PORT1)</pre>
IP_SERVER_OPEN	<p>This function opens a server port to listen for client requests.</p> <pre>S_LONG IP_SERVER_OPEN (INTEGER LocalPort, LONG ServerPort, INTEGER Protocol)</pre> <p>Parameters:</p> <ul style="list-style-type: none"> • <i>LocalPort</i>: The local port number to open. This number must be passed to IP_SERVER_CLOSE to close the port. • <i>ServerPort</i>: The number of the server port to listen on. • <i>Protocol</i>: The transport protocol to use: <ul style="list-style-type: none"> 1 = TCP 2 = UDP <p>If this parameter is not specified, TCP (1) is assumed. The constants IP_TCP and IP_UDP can be used to specify this parameter.</p> <p>Result (via ONERROR event):</p> <p>2: General Failure - Underlying OS socket call failed, reasons undefined</p> <p>10: Binding error - An error has occurred during the underlying OS "bind" function of a socket to a server port number. Possibly the server port is already being listened on.</p> <p>11: Listening error - An underlying error has occurred checking for possible client connects to a server socket.</p> <p>14: Local port already used - The local TCP client or serve port (D:P:S) is already open for use by an earlier IP_CLIENT_OPEN or IP_SERVER_OPEN.</p> <p>15: UDP socket already listening - The local UDP port (D:P:S) is already being listened on.</p> <p>16: Too many open sockets - NetLinx enforces a limit on the number of allowed open sockets. The current limit is 200. All requests to open a socket beyond this limit will fail.</p> <p>Example:</p> <pre>IP_SERVER_OPEN (PORT1, SvPort, IP_TCP)</pre>
IP_SET_OPTION	<p>Allows for specific option settings on IP client or server connections.</p> <p>The syntax:</p> <pre>IP_SET_OPTION (INTEGER LocalPort, INTEGER OptionID, INTEGER OptionValue)</pre> <p>Parameters:</p> <ul style="list-style-type: none"> • <i>LocalPort</i> - a user-defined (non-zero) integer value representing the local port on the client machine to use for this conversation. This local port number was previously specified in an IP_CLIENT_OPEN (page 100) or IP_SERVER_OPEN (page 101) call. • <i>OptionID</i> - Identifier value for the option to be set. Current valid option IDs are: <ul style="list-style-type: none"> IP_MULTICAST_TTL_OPTION - Set the time-to-live value for all outbound UDP Multicast packet transmissions on the specified port. Predefined constant option values are: <ul style="list-style-type: none"> IP_TTL_SUBNET = 1 IP_TTL_SITE = 32 IP_TTL_REGION = 64 IP_TTL_CONTINENT = 128 IP_TCP_NODELAY_OPTION - Outgoing TCP data is transmitted immediately. (default = OFF): IP_NODELAY_ON - When the NODELAY option is ON, all data is transmitted immediately upon send. This ensures that no data will be left in transmit buffers upon closure of the connection. IP_NODELAY_OFF - By default, the NODELAY option is disabled (OFF). Data will be buffered, and transmission is determined by the operating system. • <i>OptionValue</i> - Integer containing the option value. <p>Example:</p> <pre>IP_SET_OPTION (PORT1, IP_MULTICAST_TTL_OPTION, IP_TTL_REGION)</pre>

SET_IP_ADDRESS	<p>This function programs the TCP/IP configuration of the specified device. This function requires a pre-initialized <code>IP_ADDRESS_STRUCT</code> structure that will be sent to the specified device.</p> <pre>SLONG SET_IP_ADDRESS(DEV Device, IP_ADDRESS_STRUCT IPAddress)</pre> <p>NOTE: <i>SET_IP_ADDRESS takes effect after the system is rebooted.</i></p> <p>Parameters:</p> <ul style="list-style-type: none"> • Device: Device to which the IPAddress list will be sent. • IPAddress: An <code>IP_ADDRESS_STRUCT</code> containing the desired TCP/IP configuration for the specified device. <p>Result:</p> <ul style="list-style-type: none"> • 0: Operation was successful. • -1: Specified device is invalid or is not online. • -2: Time out occurred. • -3: Function is already actively attempting to set an IP Address (i.e. busy). <p>See <code>GET_IP_ADDRESS</code>, on page 97, for a description of the <code>IP_ADDRESS_STRUCT</code> structure.</p> <pre>IP_ADDRESS_STRUCT IPAddress IPAddress.Flags = 0 // use static IP address IPAddress.HostName = 'NetLinx1' // host name IPAddress.IPAddress = '19.00.100.00' IPAddress.SubnetMask = '255.255.255.0' IPAddress.Gateway = ' 19.00.100.01' Result = SET_IP_ADDRESS(0:0:0,IPAddress) // config master</pre>
SET_DNS_LIST	<p>This function programs a domain name and the list of DNS servers that the specified device will use to lookup domain names. It requires a pre-initialized <code>DNS_STRUCT</code> structure that will be sent to the specified device.</p> <pre>SLONG SET_DNS_LIST(DEV Device, DNS_STRUCT DnsList)</pre> <p>Parameters:</p> <ul style="list-style-type: none"> • Device: Device to which the DNS list will be sent • DnsList: A <code>DNS_STRUCT</code> that contains the list of DNS server IP addresses that will be programmed in to the device <p>Result:</p> <ul style="list-style-type: none"> • 0: Operation was successful • -1: Specified device is invalid or is not online • -2: Time out occurred • -3: Function is already actively attempting to set a DNS list (i.e. busy) • -4: Set DNS failed • -5: A portion of the DNS structure contains invalid information <pre>DNS_STRUCT DnsList DnsList.DomainName = 'amx.com' DnsList.DNS1 = '19.00.100.00' DnsList.DNS2 = '' DnsList.DNS3 = ''</pre> <p><code>Result = SET_DNS_LIST(0:0:0,DnsList) // set master's list</code></p> <p>See <code>GET_DNS_LIST</code>, on page 96, for a description of the <code>DNS_STRUCT</code> structure.</p>
SSH_CLIENT_CLOSE	<p>This function closes an open SSH communication port with a server.</p> <p>Syntax:</p> <pre>slong SSH_CLIENT_CLOSE(INTEGER LocalPort)</pre> <p>Parameters:</p> <ul style="list-style-type: none"> • LocalPort - A user-defined (non-zero) integer value representing the local port on the client machine to use for this conversation. This local port number must be passed to <code>SSH_CLIENT_OPEN</code> to open the conversation. <p>Returns:</p> <p>This function always returns 0. Errors are returned via the <code>DATA_EVENT_ONERROR</code> method. The following errors may be returned from the call:</p> <ul style="list-style-type: none"> 2 - General failure (out of memory) 4 - Unknown host 6 - Connection refused 7 - Connection timed out 8 - Unknown connection error 9 - Already closed 14 - Local port already used 16 - Too many open sockets <p>Example:</p> <pre>SSH_CLIENT_CLOSE(5000)</pre>

SSH_CLIENT_OPEN	<p>This function opens a port for SSH communication with a server.</p> <p>Syntax:</p> <pre>slong SSH_CLIENT_OPEN(INTEGER LocalPort, CHAR ServerAddress[], INTEGER remotePort, CHAR username[], char password[], char privateKeyPathname[], char privateKeyPassphrase[])</pre> <p>Parameters:</p> <ul style="list-style-type: none"> LocalPort- A user-defined (non-zero) integer value representing the local port on the client machine to use for this conversation. This local port number must be passed to SSH_CLIENT_CLOSE to close the conversation. ServerAddress - A string containing either the IP address (in dotted-quad-notation) or the domain name of the server to which you want to connect. remotePort - The port number on the server that identifies the program or service that the client is requesting, typically 22 username - Login user name password - Password for the user name, null if using PKI privateKeyPathname - Path to private key privateKeyPassphrase - Password for private key. <p>Returns:</p> <p>This function always returns 0. Errors are returned via the DATA_EVENT ONERROR method. The following errors may be returned from the call:</p> <ul style="list-style-type: none"> 2 - General failure (out of memory) 4 - Unknown host 6 - Connection refused 7 - Connection timed out 8 - Unknown connection error 9 - Already closed 14 - Local port already used 16 - Too many open sockets <p>Example:</p> <pre>SSH_CLIENT_OPEN(5000, '192.168.0.1', 22, 'user1', 'password', '/certs/id_rsa', '')</pre>
TLS_CLIENT_CLOSE	<p>Closes an open TLS communication port with a remote device. Typically, the remote host closes the connection and you do not need to send this command.</p> <p>Syntax:</p> <pre>integer TLS_CLIENT_CLOSE(LocalPort)</pre> <p>Parameters:</p> <p>LocalPort - A user-defined (non-zero) integer value representing the local port on the client machine to use for this conversation. This local port number must be passed to TLS_CLIENT_OPEN to open the conversation.</p> <p>Returns:</p> <ul style="list-style-type: none"> 0 - Success 1 - Error <p>Example:</p> <pre>TLS_CLIENT_CLOSE(443)</pre>
TLS_CLIENT_OPEN	<p>Opens a port for TLS communication with a remote device.</p> <p>Syntax:</p> <pre>integer TLS_CLIENT_OPEN(LocalPort, hostname, port, mode)</pre> <p>Parameters:</p> <ul style="list-style-type: none"> LocalPort - A user-defined (non-zero) integer value representing the local port on the client machine to use for this conversation. This local port number must be passed to TLS_CLIENT_CLOSE to close the conversation. hostname - The host name or IP address of the remote host. port - The connecting port on the remote host, usually port 443 for standard HTTPS connections. mode - 0: TLS_VALIDATE_CERTIFICATE (perform certificate validation), 1:TLS_IGNORE_CERTIFICATE_ERRORS (connect to the remote site while ignoring certificate errors or mismatches) <p>Returns:</p> <p>This function returns 0 if all parameters are accepted, or a positive value indicating the offending parameter if there is an error.</p> <p>Example:</p> <pre>TLS_CLIENT_OPEN(443, '192.168.0.1', 443, 0)</pre>

ADD_URL_ENTRY Flags Member Bit Fields

The Flags member is a bit field that is used for several different purposes, as defined below:

ADD_URL_ENTRY Flags Member Bit Fields				
Bit		Mathematic Value	Normal Value	Meaning
Bit 0	1	(0x01)	1	0 = Establishes a UDP connection. 1 = Establishes a TCP connection.
Bit 1	2	(0x02)	0	0 = Account information not included 1 = Include account information (User Name / Password) required to connect to remote URL
Bit 2	4	(0x04)	0	Unused
Bit 3	8	(0x08)	0	Unused
Bit 4	16	(0x10)	0	Establishes a Temp Connection. A Temp Connection is one that is set, but is not stored in flash, and therefore is not restored when the master reboots. If the NetLinX code is adding URL entries, it is recommended to make them temporary so that the flash is not constantly being written, especially since the code handles all the connections anyway.
Bit 5	32	(0x20)	0	Source of URL. 0 = Programmed by the IDE. 1 = Programmed by NetLinX ADD_URL_ENTRY.
Bit 6	64	(0x40)	0	Encoded status indication (Read only). These 2 bits together form one of 4 possible codes indicating the status of the connection. <ul style="list-style-type: none"> • 0x00 - Looking up IP address or URL. • 0x40 - Connecting to URL. • 0x80 - Waiting for connection to establish. • 0xC0 - Connected.
Bit 7	128	(0x80)	0x00	

GET_IP_ADDRESS Flags Member Bit Fields

The Flags member is a bit field that is used for several different purposes, as defined below:

GET_IP_ADDRESS Flags Member Bit Fields				
Bit		Mathematic Value	Normal Value	Meaning
Bit 0	1	(0x01)	1	0 = Use the provided static IP address 1 = Use DHCP to obtain an IP address
Bit 1	2	(0x02)	0	Unused
Bit 2	4	(0x04)	0	Unused
Bit 3	8	(0x08)	0	Unused
Bit 4	16	(0x10)	0	Unused
Bit 5	32	(0x20)	0	Unused
Bit 6	64	(0x40)	0	Unused
Bit 7	128	(0x80)	0x00	Unused

Level Keywords

NetLinx supports the following LEVEL keywords:

LEVEL Keywords	
~LEVSYNCON	<p>Enables a feature that helps synchronize level values. By default, this feature is disabled for compatibility reasons.</p> <p>The synchronization algorithm works by setting the level value of a level five seconds after receiving a level value from a level. While it may not be apparent, this makes sure that level values remain in sync with each other if they ever get out of sync.</p> <p>The only way levels could ever get out of sync is when the situation of "dueling levels" arises. A typical example of "dueling levels" is when two touch panels with active sliders are combined with a volume control. If one slider attempts to raise the volume level while the other is attempting to lower the volume level the level value bounces back and forth somewhere between the desired levels. If both sliders are released at the exact same time, it is possible that one of level values displayed on the touch panel's slider is inaccurate.</p> <p>The level synchronization algorithm corrects the incorrect level five seconds after activity ceases.</p> <p>The commands are <code>~LEVSYNCON</code> and <code>~LEVSYNCOFF</code> are sent to the level that should have the synchronization algorithm enabled or disabled. The command itself is never sent to the device because the master intercepts the command and processes it internally.</p> <p>Both commands accept a single parameter that specifies the level number. Using the "dueling levels" example above, the following send commands will turn on the synchronization algorithm for level #1 of Touch Panel 1, level #4 of touch panel #2, and level #2 of the volume control.</p> <pre>SEND_COMMAND dvTouchPanel1, '~LEVSYNCON 1' SEND_COMMAND dvTouchPanel2, '~LEVSYNCON 4' SEND_COMMAND dvVolume, '~LEVSYNCON 2'</pre> <p>Note that for some devices, turning the level synchronization algorithm on can cause undesired results. The undesired results will vary from device to device so it is difficult to indicate any specific failure mode. Keep in mind that the algorithm should only be turned on when necessary. Also note that the <code>LEVSYNCON</code> and <code>LEVSYNCOFF</code> <code>SEND_COMMANDS</code> may not be sent to remote devices (devices that belong to other systems) and only the device's master may issue these commands.</p>
~LEVSYNCOFF	Disables a feature that helps synchronize level values. By default, this feature is disabled for compatibility reasons.
COMBINE_LEVELS	See page 46.
CREATE_LEVEL	<p>This keyword creates an association between a specified level of a device and a variable that will contain the value of the level. This can only appear in the <code>DEFINE_START</code> section of the program.</p> <pre>CREATE_LEVEL DEV, Level, Value</pre> <p>Parameters:</p> <ul style="list-style-type: none"> <code>DEV</code>: The device from which to read the level. <code>Level</code>: The level of the device to read. <code>Value</code>: Variable in which to store the level value. <code>DevLev</code>: A <code>DEVLEV</code> structure. <code>Value</code>: Variable in which to store the level value <code>CREATE_LEVEL DevLev, Value</code>. <p>During execution of the program, NetLinx continuously updates the variable to match the level it represents.</p>
DEFINE_CONNECT_LEVEL	See page 46.
SEND_LEVEL	<p>This keyword sends a value to a specific level on a NetLinx device/port. The syntax follows any one of the four following examples:</p> <pre>SEND_LEVEL DEV, Level, Value SEND_LEVEL DEV[], Level, Value SEND_LEVEL DEVLEV, Value SEND_LEVEL DEVLEV[], Value</pre> <p>Parameters:</p> <ul style="list-style-type: none"> <code>DEV</code>: Device containing the specified level. <code>Level</code>: Number of the level to receive the new value. <code>Value</code>: New level value. <code>DEV[]</code>: Device array (each device contains the specified level). <code>DEVLEV</code>: Device-level to receive the new value. <code>DL[]</code>: Device-level array (each will receive the new value).
SET_VIRTUAL_LEVEL_COUNT	See page 123.

Listview Keywords

The NetLinx programming language supports the following Listview keywords. These keywords support the Listview and Dynamic Data functionality in Modero G5 touch panels and TPDesign5:

Listview Keywords	
LISTVIEW_ON_ROW_SELECT_EVENT	<p>LISTVIEW_ON_ROW_SELECT_EVENT is a Custom Event that is raised in response to a user selection of an item in a Listview button. When the user selects an item on the Listview button, a LISTVIEW_ON_ROW_SELECT_EVENT is raised and the entire data feed record for that selection is sent to the master. The user can then use DATA_GET_EVENT_RECORD to retrieve the specific values of interest.</p> <p>NOTE: "payloadId" specifies the data access identifier to be retrieved from the custom event object, and is predefined as "custom.value1". "payloadType" specifies the dataType to be retrieved from the custom event object and is predefined as "custom.value2".</p> <p>The following code example illustrates how the LISTVIEW_ON_ROW_SELECT_EVENT Custom Event is used to retrieve two data fields ('name' and 'number') when a listview item is selected.</p> <pre>// The custom event that is raised whenever a listview item is // selected on the panel CUSTOM_EVENT[dvTP,btnListview,LISTVIEW_ON_ROW_SELECT_EVENT] { SLONG payloadId SLONG payloadType // just a char array to hold the data we want to use in the // custom event. CHAR fields[2][16] //char variables to hold our data for "name" & "number" CHAR name[DATA_MAX_VALUE_LENGTH] CHAR number[DATA_MAX_VALUE_LENGTH] // variable record, of type DATA_RECORD, to hold the record // we retrieve from the custom event DATA_RECORD record // Get the data access ID from the custom event // variable is payloadID - custom.value1 is predefined payloadId = custom.value1 // Get the data type from the custom event // variable is payloadType - custom.value2 is predefined payloadType = custom.value2 if (payloadId > 0 && payloadType == DATA_STRUCTURE_DATARECORD) { // Specify which fields we want to retrieve from the payload // (these are the IDs we defined earlier) fields[1] = 'name' fields[2] = 'number' // Retrieve the record and get our requested fields if (DATA_GET_EVENT_RECORD(dvTP, payloadId, fields, record) > 0) { // The record existed and contained our fields // let's retrieve the values that we are interested in name = record.content[1].value number = record.content[2].value // Send the name & number that was retrieved to the // appropriate buttons & show the popup SEND_COMMAND dvTP, "^TXT-50,0,',name" SEND_COMMAND dvTP, "^TXT-51,0,',number" SEND_COMMAND dvTP, "^PPN-Calling'" } } }</pre>
DATA_FEED	<p>The DATA_FEED structure contains information describing a Listview Dynamic Data feed.</p> <p>DATA_FEED structure fields:</p> <ul style="list-style-type: none"> • NAME - A string identifying the data feed name • DESCRIPTION - A string containing a short description of the data feed • SOURCE - A string describing the source of the data feed • LASTUPDATE - A LONG value to indicate the time of the last update <p>NOTE: See the "Listview Buttons & Dynamic Data" section of the TP5 Instruction Manual for a detailed description of format and usage of the DATA_FEED structure.</p>

Listview Keywords (Cont.)	
DATA_FIELD	<p>The DATA_FIELD structure contains information describing an individual data field within a DATA_RECORD metadata or content.</p> <p>DATA_FIELD structure fields:</p> <ul style="list-style-type: none"> • ID - A string containing a unique identifier for the field • TYPE - A string containing the field type. Valid data field types are: <ul style="list-style-type: none"> DATA_TYPE_UNKNOWN DATA_TYPE_STRING DATA_TYPE_DATETIME DATA_TYPE_DATE DATA_TYPE_TIME DATA_TYPE_IMAGE • FORMAT - A string containing the field format. Valid data field formats are: <ul style="list-style-type: none"> DATA_FORMAT_URL DATA_FORMAT_PHONE DATA_FORMAT_EMAIL DATA_FORMAT_ISO8601 • LABEL - A string containing the field label • VALUE - A string containing the field value <p>NOTE: See the "Listview Buttons & Dynamic Data" section of the TP5 Instruction Manual for a detailed description of format and usage of the DATA_FEED structure.</p>
DATA_RECORD	<p>The DATA_RECORD structure contains information describing a data record within a data feed.</p> <p>DATA_RECORD structure fields:</p> <ul style="list-style-type: none"> • METADATA - DATA_FIELD array containing a list of metadata values associated with the record • CONTENT - DATA_FIELD array containing a list of data fields for the record <p>NOTE: See the "Listview Buttons & Dynamic Data" section of the TP5 Instruction Manual for a detailed description of format and usage of the DATA_FEED structure.</p>
WC_DATA_FEED	<p>The WC_DATA_FEED structure contains information describing a WIDECHAR Listview Dynamic Data feed.</p> <p>WC_DATA_FEED structure fields:</p> <ul style="list-style-type: none"> • NAME - A string identifying the data feed name • DESCRIPTION - A WIDECHAR string containing a short description of the data feed • SOURCE - A WIDECHAR string describing the source of the data feed • LASTUPDATE - A LONG value to indicate the time of the last update <p>NOTE: See the "Listview Buttons & Dynamic Data" section of the TP5 Instruction Manual for a detailed description of format and usage of the DATA_FEED structure.</p>
WC_DATA_FIELD	<p>The WC_DATA_FIELD structure contains information describing an individual data field within a WC_DATA_RECORD metadata or content.</p> <p>WC_DATA_FIELD structure fields:</p> <ul style="list-style-type: none"> • ID - A WIDECHAR string containing a unique identifier for the field • TYPE - A string containing the field type. Valid data field types are: <ul style="list-style-type: none"> DATA_TYPE_UNKNOWN DATA_TYPE_STRING DATA_TYPE_DATETIME DATA_TYPE_DATE DATA_TYPE_TIME DATA_TYPE_IMAGE • FORMAT - A string containing the field format. Valid data field formats are: <ul style="list-style-type: none"> DATA_FORMAT_URL DATA_FORMAT_PHONE DATA_FORMAT_EMAIL DATA_FORMAT_ISO8601 • LABEL - A WIDECHAR string containing the field label • VALUE - A WIDECHAR string containing the field value <p>NOTE: See the "Listview Buttons & Dynamic Data" section of the TP5 Instruction Manual for a detailed description of format and usage of the DATA_FEED structure.</p>
WC_DATA_RECORD	<p>The WC_DATA_RECORD structure contains information describing a WIDECHAR data record within a WIDECHAR data feed. WC_DATA_RECORD structure fields:</p> <ul style="list-style-type: none"> • METADATA - WC_DATA_FIELD array containing a list of metadata values associated with the record • CONTENT - WC_DATA_FIELD array containing a list of data fields for the record <p>NOTE: See the "Listview Buttons & Dynamic Data" section of the TP5 Instruction Manual for a detailed description of format and usage of the WC_DATA_RECORD structure.</p>

Listview Keywords (Cont.)	
DATA_CREATE_FEED	<p>The DATA_CREATE_FEED function creates a NetLinx data feed with the supplied values.</p> <p>Syntax: <code>SINTEGER DATA_CREATE_FEED (DATA_FEED FEED)</code></p> <p>Parameters:</p> <ul style="list-style-type: none"> FEED: A DATA_FEED structure populated with the desired data feed identification values <p>Result: 1 = Data feed created -1 = Data feed create failed due to invalid parameter</p> <p>Example: <pre>STACK_VAR DATA_FEED datafeed // ----- // CREATE A NEW DATA FEED // ----- datafeed.name = 'phonenumber' datafeed.description = 'Employees' datafeed.source = 'netlinx Listview Example code' DATA_CREATE_FEED(datafeed)</pre></p> <p>NOTE: See the "Listview Buttons & Dynamic Data" section of the TPDS Instruction Manual for a detailed description of format and usage of the WC_DATA_RECORD structure.</p>
DATA_DELETE_FEED	<p>The DATA_DELETE_FEED function deletes the NetLinx data feed with the specified name.</p> <p>Syntax: <code>SINTEGER DATA_DELETE_FEED (CHAR FEED[])</code></p> <p>Parameters:</p> <ul style="list-style-type: none"> FEED: A string containing the name of the data feed to delete <p>Result: 1 = Data feed deleted -1 = Data feed create failed due to invalid parameter</p> <p>Example: <pre>DATA_DELETE_FEED('phonenumber')</pre></p> <p>NOTE: See the "Listview Buttons & Dynamic Data" section of the TPDS Instruction Manual for a detailed description of format and usage of the WC_DATA_RECORD structure.</p>
DATA_PUBLISH_FEED	<p>The DATA_PUBLISH_FEED function publishes the specified data feed to a file and returns a string containing the URL reference to the file.</p> <p>Syntax: <code>CHAR[] DATA_PUBLISH_FEED (CHAR FEED[])</code></p> <p>Parameters:</p> <ul style="list-style-type: none"> FEED: A string containing the name of the data feed to publish <p>Result: A string containing the URL of the published data feed file OR a textual error message indicating a publish failure</p> <p>Example: <pre>DEFINE_VARIABLE STACKVAR CHAR publishedURL[DATA_MAX_VALUE_LENGTH] publishedURL = DATA_PUBLISH_FEED('phonenumber')</pre></p> <p>NOTE: See the "Listview Buttons & Dynamic Data" section of the TPDS Instruction Manual for a detailed description of format and usage of the WC_DATA_RECORD structure.</p>
DATA_GET_PUBLISHED_FEED	<p>The DATA_GET_PUBLISHED_FEED function returns the URL of an already published feed matching the specified data feed name.</p> <p>Syntax: <code>CHAR[] DATA_GET_PUBLISHED_FEED (CHAR FEED[])</code></p> <p>Parameters:</p> <ul style="list-style-type: none"> FEED: A string containing the name of the published data feed <p>Result: A string containing the URL of the published data feed file OR a textual error message indicating an error</p> <p>Example: <pre>DEFINE_VARIABLE STACKVAR CHAR publishedURL[DATA_MAX_VALUE_LENGTH] publishedURL = DATA_GET_PUBLISHED_FEED('phonenumber')</pre></p> <p>NOTE: See the "Listview Buttons & Dynamic Data" section of the TPDS Instruction Manual for a detailed description of format and usage of the WC_DATA_RECORD structure.</p>

Listview Keywords (Cont.)	
DATA_ADD_RECORD	<p>The <code>DATA_ADD_RECORD</code> function adds a new record to a data feed.</p> <p>Syntax: <code>SINTEGER DATA_ADD_RECORD (CHAR FEED[], CHAR [] RECORDSET_ID, DATA_RECORD REC)</code></p> <p>Parameters:</p> <ul style="list-style-type: none"> • FEED: A string containing the name of the data feed to add the record to • RECORDSET_ID: A string containing the name of the record set the record belongs to • REC: A <code>DATA_RECORD</code> containing the record values to add to the data feed <p>Result:</p> <ul style="list-style-type: none"> 1 = Record added -1 = Record failed to add due to invalid parameter <p>Example:</p> <pre>STACK_VAR DATA_RECORD record // Records can have metadata fields and content fields. In this // example we won't use any metadata SET_LENGTH_ARRAY(record.metadata, 0) // We will have 3 content fields per record: photo, name and phone number SET_LENGTH_ARRAY(record.content, 3) // Initialize the field attributes that will be the same for every record // the first field in a record will be the image record.content[1].id = 'photo'; record.content[1].type = DATA_TYPE_IMAGE; record.content[1].format = DATA_FORMAT_URL; // The label can be something different from the id but in our case we'll // keep them the same record.content[1].label = 'photo'; // The second field in a record will be the name record.content[2].id = 'name'; record.content[2].type = DATA_TYPE_STRING; record.content[2].format = ''; record.content[2].label = 'name'; // The third field will be the phone number record.content[3].id = 'number'; record.content[3].type = DATA_TYPE_STRING; record.content[3].format = DATA_FORMAT_PHONE; record.content[3].label = 'number'; // The next step is to put in the actual values for the 3 fields // Do this for the first record record.content[1].value = 'http://192.168.222.333/ftp/listview/hunter.jpg' record.content[2].value = 'Hunter Pence' record.content[3].value = '888-555-1111' // Add the record to the feed phonelist data feed DATA_ADD_RECORD('phonelist', 'phonelist', record)</pre> <p>NOTE: See the "Listview Buttons & Dynamic Data" section of the <i>TPD5 Instruction Manual</i> for a detailed description of format and usage of the <code>WC_DATA_RECORD</code> structure.</p>
DATA_GET_EVENT_RECORD	<p>The <code>DATA_GET_EVENT_RECORD</code> function retrieves data feed event record values from a data feed custom event.</p> <p>Syntax: <code>SINTEGER DATA_GET_EVENT_RECORD (DEV device, LONG payloadID, char fields[][], DATA_RECORD rec)</code></p> <p>Parameters:</p> <ul style="list-style-type: none"> • device: NetLinX device event is coming from • payloadID: Payload identifier supplied in custom event value1 • fields: array of strings specifying what fields from the record to return • rec: <code>DATA_RECORD</code> structure containing the desired field values from the data feed event <p>Result:</p> <ul style="list-style-type: none"> 1 = Record values retrieved -1 = Failed to retrieve values due to invalid parameter <p>Example:</p> <pre>CUSTOM_EVENT[dvTP,btnListview,LISTVIEW_ON_ROW_SELECT_EVENT] { SLONG payloadID SLONG payloadType CHAR fields[2][16] CHAR name[DATA_MAX_VALUE_LENGTH] CHAR number[DATA_MAX_VALUE_LENGTH] DATA_RECORD record // Get the data access ID from the custom event payloadID = custom.value1</pre>

Listview Keywords (Cont.)	
DATA_GET_EVENT_RECORD (Cont.)	<pre>// Get the data type from the custom event payloadType = custom.value2 Listview Buttons & Dynamic Data 108 TPDesign5 - G5 Touch Panel Design/Programming if (payloadID > 0 && payloadType == DATA_STRUCTURE_DATAARECORD) { // Specify which fields we want to retrieve from the payload fields[1] = 'name' fields[2] = 'number' // Populate a record with the requested fields from the event if (DATA_GET_EVENT_RECORD(dvTP, payloadID, fields, record) > 0) { // All is well so far so retrieve the values that we are // interested in from the selection that the user made on // the panel. name = record.content[1].value number = record.content[2].value // Put the name and number that was selected on a popup and // show the popup SEND_COMMAND dvTP,"^TXT-50,0,',name" SEND_COMMAND dvTP,"^TXT-51,0,',number" SEND_COMMAND dvTP,"^PPN-Calling!" } } }</pre> <p>NOTE: See the "Listview Buttons & Dynamic Data" section of the TPDS Instruction Manual for a detailed description of format and usage of the WC_DATA_RECORD structure.</p>
_WC_DATA_CREATE_FEED	<p>The _WC_DATA_CREATE_FEED function creates a WIDECHAR NetLinX data feed with the supplied values.</p> <p>Syntax: SINTEGER _WC_DATA_CREATE_FEED (WC_DATA_FEED FEED)</p> <p>Parameters:</p> <ul style="list-style-type: none"> FEED: A WC_DATA_FEED structure populated with the desired data feed identification values <p>Result: 1 = Data feed created -1 = Data feed create failed due to invalid parameter</p> <p>NOTE: See the "Listview Buttons & Dynamic Data" section of the TPDS Instruction Manual for a detailed description of format and usage of the WC_DATA_RECORD structure.</p>
_WC_DATA_ADD_RECORD	<p>The _WC_DATA_ADD_RECORD function adds a new record to a WIDECHAR data feed.</p> <p>Syntax: SINTEGER _WC_DATA_ADD_RECORD (CHAR FEED[], WIDECHAR [] RECORDSET_ID, WC_DATA_RECORD REC)</p> <p>Parameters:</p> <ul style="list-style-type: none"> FEED: A string containing the name of the data feed to add the record to RECORDSET_ID: A WIDECHAR string containing the name of the record set the record belongs to REC: A WC_DATA_RECORD containing the record values to add to the data feed <p>Result: 1 = Record added -1 = Record failed to add due to invalid parameter</p> <p>NOTE: See the "Listview Buttons & Dynamic Data" section of the TPDS Instruction Manual for a detailed description of format and usage of the WC_DATA_RECORD structure.</p>
_WC_DATA_GET_EVENT_RECORD	<p>The _WC_DATA_GET_EVENT_RECORD function retrieves WIDECHAR data feed event record values from a data feed custom event.</p> <p>Syntax: SINTEGER _WC_DATA_GET_EVENT_RECORD (DEV device, LONG payloadID, WIDECHAR fields[][], WC_DATA_RECORD rec)</p> <p>Parameters:</p> <ul style="list-style-type: none"> device: NetLinX device event is coming from payloadID: Payload identifier supplied in custom event value1 fields: array of WIDECHAR strings specifying what fields from the record to return rec: WC_DATA_RECORD structure containing the desired field values from the data feed event <p>Result: 1 = Record values retrieved -1 = Failed to retrieve values due to invalid parameter</p> <p>NOTE: See the "Listview Buttons & Dynamic Data" section of the TPDS Instruction Manual for a detailed description of format and usage of the WC_DATA_RECORD structure.</p>

Log Keywords

The NetLinx programming language supports the following Log keywords:

Log Keywords	
SET_LOG_LEVEL	<p>Sets the current log level for the program. All subsequent logs at the specified level or lower will cause a log message out the NetLinx master's logging facilities.</p> <p>NOTE: <i>The final terminal output is further filtered based on the terminal session "msg on" level. See the MSG ON OFF Terminal Command (in the NX Controllers WebConsole and Programming Guide) for more information.</i></p> <p>Syntax:</p> <pre>SET_LOG_LEVEL (CONSTANT INTEGER LEVEL)</pre> <p>The four valid log levels are:</p> <ul style="list-style-type: none"> • INTEGER AMX_ERROR = 1 • INTEGER AMX_WARNING = 2 • INTEGER AMX_INFO = 3 • INTEGER AMX_DEBUG = 4
GET_LOG_LEVEL	<p>Retrieves the current log level for the program.</p> <pre>INTEGER GET_LOG_LEVEL ()</pre> <p>Where the returned value will be one of the for log levels:</p> <ul style="list-style-type: none"> • INTEGER AMX_ERROR = 1 • INTEGER AMX_WARNING = 2 • INTEGER AMX_INFO = 3 • INTEGER AMX_DEBUG = 4
AMX_LOG	<p>Sends the specified message to the NetLinx master's logging facilities if the current log level setting is at least as large as LEVEL. For example, if the current log level setting is AMX_WARNING, calling log with level of AMX_ERROR will cause a log, while AMX_INFO would not.</p> <p>NOTE: <i>This command is supported by NetLinx Controller firmware version 4 or higher.</i></p> <p>NOTE: <i>The final terminal output is further filtered based on the terminal session "msg on" level. See the MSG ON OFF Terminal Command (in the NX Controllers WebConsole and Programming Guide) for more information.</i></p> <p>The AMX_LOG function is meant to replace the "SEND_STRING 0,..." log method.</p> <pre>AMX_LOG (CONSTANT INTEGER LEVEL, CHAR MSG [])</pre> <p>Where level is one of the following values:</p> <ul style="list-style-type: none"> • INTEGER AMX_ERROR = 1 • INTEGER AMX_WARNING = 2 • INTEGER AMX_INFO = 3 • INTEGER AMX_DEBUG = 4 <p>Example:</p> <pre>AMX_LOG (AMX_ERROR, "' FAILURE OCCURRED, VALUE=' , ITOA (ERR_VAL) ")</pre>

Math Functions

Math functions are supported by NetLinx Controller firmware version 4 or higher. The NetLinx programming language supports the following Math Function keywords:

Math Function Keywords	
EXP_VALUE	Returns the base-e exponential function of x, which is the e number raised to the power of x. EXP_VALUE (CONSTANT VARIANT X) Where X can be any intrinsic type. (INTEGER, FLOAT, DOUBLE, etc)
LOG_VALUE	Returns the natural logarithm of x. The natural logarithm is the base-e logarithm, the inverse of the natural exponential function (EXP_VALUE). LOG_VALUE (CONSTANT VARIANT X) Where X can be any intrinsic type (INTEGER, FLOAT, DOUBLE, etc) with a value greater than 0.
LOG10_VALUE	Returns the common (base-10) logarithm of x. LOG10_VALUE (CONSTANT VARIANT X) Where X can be any intrinsic type (INTEGER, FLOAT, DOUBLE, etc) with a value greater than 0.
POWER_VALUE	Returns BASE raised to the power EXPONENT. POWER_VALUE (CONSTANT VARIANT BASE, CONSTANT VARIANT EXPONENT) Where BASE and EXPONENT can be any intrinsic type (INTEGER, FLOAT, DOUBLE, etc). The following combinations are error conditions which will return 0: <ul style="list-style-type: none"> • "BASE = 0 and EXPONENT=negative • "BASE=negative and EXPONENT=non-integral value
SQRT_VALUE	Returns the square root of x. SQRT_VALUE (CONSTANT VARIANT X) Where X can be any intrinsic type (INTEGER, FLOAT, DOUBLE, etc) with a value greater than 0.

Module Keywords

NetLinx Modules

The ability to reuse code is a desirable goal in software development; however, code reuse takes careful planning and organization. As discussed earlier, NetLinx provides tools such as functions and modules to promote reusability. Modules are NetLinx sub-programs designed to be "plugged into" a main program.

Defining a Module

The MODULE_NAME entry on the first line of the file defines the module. The syntax is:

```
MODULE_NAME = '<module name>' [(<parameter list>)]
```

The MODULE_NAME entry identifies the file as containing a NetLinx module, as opposed to a standard NetLinx source code file. The module name is any valid string literal not to exceed 64 characters. A file can contain only one module and the file name must be the same as the module name with the addition of the ".AXS" extension. Module parameters behave exactly like subroutine parameters; the parameter list is optional. The value for each parameter is set either by the main program or another module. If the value of a parameter is changed, both the main program and module see the change.

NOTE: *Constants and expressions cannot be used as arguments in the parameter list.*

The example below defines a module named ModuleExample. Aside from the MODULE_NAME entry, the code looks like any standard NetLinx source code file. All parameters to a module must be one of the intrinsic types: CHAR, INTEGER, SINTEGER, LONG, SLONG, FLOAT, DOUBLE, DEV, DEVCHAN or DEVLEV. Also, any of the above array types can be used.

```
MODULE_NAME='ModuleExample'(DEV dvDECK, DEVCHAN dcTRANSPORTS[], INTEGER nFIRST)
(*{PS_SOURCE_INFO(PROGRAM STATS) *)
(*****)
(* ORPHAN_FILE_PLATFORM: 1 *)
(*****)
(*)}PS_SOURCE_INFO *)
(*****)
(* DEVICE NUMBER DEFINITIONS GO BELOW *)
(*****)
DEFINE_DEVICE

(*****)
(* CONSTANT DEFINITIONS GO BELOW *)
(*****)
DEFINE_CONSTANT

NO_BUTTON = 0
NO_FUNCTION = 256

PLAY = 1
STOP = 2
PAUSE = 3
FFWD = 4
REW = 5
SFWD = 6
SREV = 7
REC = 8

PLAY_FB = 241
STOP_FB = 242
PAUSE_FB = 243
FFWD_FB = 244
REW_FB = 245
SFWD_FB = 246
SREV_FB = 247
REC_FB = 248

(* vcr will go into stop after rewinding for a certain time *)
VCR1_REW_TO_STOP = 1800 (* 3 min *)

(* vcr will go into stop after search rewinding for a certain time *)
VCR1_SREV_TO_STOP = 12000 (* 20 min *)

(* vcr will go into stop after being paused for a certain time *)
VCR1_PAUSE_TO_STOP = 6000 (* 10 min *)

(* button feedback flag *)
VCR1_DEFEAT_FEEDBACK = 0
```

```

(*****)
(*          TYPE DEFINITIONS GO BELOW          *)
(*****)
DEFINE_TYPE*)

(*****)
(*          VARIABLE DEFINITIONS GO BELOW      *)
(*****)

DEFINE_VARIABLE

VOLATILE INTEGER nOFFSET_FN      (* FUNCTION OFFSET *)
VOLATILE INTEGER nOFFSET_FB      (* FEEDBACK OFFSET *)
VOLATILE INTEGER nFUNC           (* FUNCTION THAT WAS PRESSED *)

(*****)
(*          SUBROUTINE DEFINITIONS GO BELOW    *)
(*****)
DEFINE_CALL 'ALL OFF'
{
  OFF [dvDECK,nOFFSET_FN+PLAY]
  OFF [dvDECK,nOFFSET_FN+STOP]
  OFF [dvDECK,nOFFSET_FN+PAUSE]
  OFF [dvDECK,nOFFSET_FN+FFWD]
  OFF [dvDECK,nOFFSET_FN+REW]
  OFF [dvDECK,nOFFSET_FN+SFW]
  OFF [dvDECK,nOFFSET_FN+SREV]
  OFF [dvDECK,nOFFSET_FN+REC]
}

DEFINE_CALL 'FEEDBACK' (INTEGER nFUNCTION)
{
  [dvDECK,nOFFSET_FB+PLAY_FB] = (nFUNCTION=PLAY)
  [dvDECK,nOFFSET_FB+STOP_FB] = (nFUNCTION=STOP)
  [dvDECK,nOFFSET_FB+PAUSE_FB] = (nFUNCTION=PAUSE)
  [dvDECK,nOFFSET_FB+FFWD_FB] = (nFUNCTION=FFWD)
  [dvDECK,nOFFSET_FB+REW_FB] = (nFUNCTION=REW)
  [dvDECK,nOFFSET_FB+SFW_FB] = (nFUNCTION=SFW)
  [dvDECK,nOFFSET_FB+SREV_FB] = (nFUNCTION=SREV)
  [dvDECK,nOFFSET_FB+REC_FB] = (nFUNCTION=REC)
}
(*****)
(*          STARTUP CODE GOES BELOW          *)
(*****)
DEFINE_START

(* SELECT OFFSETS IF ANY *)
IF (nFIRST BAND $00FF)
  nOFFSET_FN=(nFIRST BAND $00FF)-PLAY
ELSE
  nOFFSET_FN=0

IF (nFIRST BAND $FF00)
  nOFFSET_FB=((nFIRST BAND $FF00)/$FF)-PLAY_FB
ELSE
  nOFFSET_FB=0

(*****)
(*          EVENT PROCESSING ROUTINES BELOW  *)
(*****)

DEFINE_EVENT

(*****)
(* dcTRANSPORTS - TRANSPORT CONTROLS      *)
(*****)

BUTTON_EVENT[dcTRANSPORTS]
{
  PUSH:
  {
    #IF_DEFINED SYSCALL_NOTIFY
    SEND_STRING 0,"'IN MODULE ',39,'ModuleExample',39"
    #END_IF
  }
}

```

```

(* RUN A FUNCTION *)
nFUNC = GET_LAST(dcTRANSPORTS)
SWITCH (nFUNC)
{
CASE PLAY:
{
IF (![dvDECK,nOFFSET_FB+REC_FB])
{
CANCEL_WAIT 'VCR1 REW TO STOP'
CANCEL_WAIT 'VCR1 PAUSE TO STOP'
CANCEL_WAIT 'VCR1 SREV TO STOP'
CALL 'ALL OFF'
MIN_TO [dvDECK,nOFFSET_FN+PLAY]
CALL 'FEEDBACK' (PLAY)
}
}
}

CASE STOP:
{
CANCEL_WAIT 'VCR1 REW TO STOP'
CANCEL_WAIT 'VCR1 PAUSE TO STOP'
CANCEL_WAIT 'VCR1 SREV TO STOP'
CALL 'ALL OFF'
MIN_TO [dvDECK,nOFFSET_FN+STOP]
CALL 'FEEDBACK' (STOP)
}
}

CASE PAUSE:
{
SELECT
{
ACTIVE ([dvDECK,nOFFSET_FB+PAUSE_FB]
AND [dvDECK,nOFFSET_FB+REC_FB]
AND dcTRANSPORTS[8].CHANNEL<NO_FUNCTION):
{
CANCEL_WAIT 'VCR1 REW TO STOP'
CANCEL_WAIT 'VCR1 PAUSE TO STOP'
CANCEL_WAIT 'VCR1 SREV TO STOP'
CALL 'ALL OFF'
MIN_TO [dvDECK,nOFFSET_FN+REC]
CALL 'FEEDBACK' (REC)
}
}
ACTIVE ([dvDECK,nOFFSET_FB+PAUSE_FB]
AND dcTRANSPORTS[1].CHANNEL<NO_FUNCTION):
{
CANCEL_WAIT 'VCR1 REW TO STOP'
CANCEL_WAIT 'VCR1 PAUSE TO STOP'
CANCEL_WAIT 'VCR1 SREV TO STOP'
CALL 'ALL OFF'
MIN_TO [dvDECK,nOFFSET_FN+PLAY]
CALL 'FEEDBACK' (PLAY)
}
}
ACTIVE ([dvDECK,nOFFSET_FB+PLAY_FB]):
{
CANCEL_WAIT 'VCR1 REW TO STOP'
CANCEL_WAIT 'VCR1 PAUSE TO STOP'
CANCEL_WAIT 'VCR1 SREV TO STOP'
WAIT VCR1_PAUSE_TO_STOP 'VCR1 PAUSE TO STOP'
SYSTEM_CALL 'FUNCTION' (dvDECK,STOP,nFIRST)
CALL 'ALL OFF'
MIN_TO [dvDECK,nOFFSET_FN+PAUSE]
CALL 'FEEDBACK' (PAUSE)
}
}
ACTIVE ([dvDECK,nOFFSET_FB+REC_FB]):
{
CANCEL_WAIT 'VCR1 REW TO STOP'
CANCEL_WAIT 'VCR1 PAUSE TO STOP'
CANCEL_WAIT 'VCR1 SREV TO STOP'
WAIT VCR1_PAUSE_TO_STOP 'VCR1 PAUSE TO STOP'
SYSTEM_CALL 'FUNCTION' (dvDECK,STOP,nFIRST)
CALL 'ALL OFF'
MIN_TO [dvDECK,nOFFSET_FN+PAUSE]
CALL 'FEEDBACK' (PAUSE)
ON [dvDECK,nOFFSET_FB+REC_FB]
}
}
}

```

```

    }
}

CASE FFWD:
{
  SELECT
  {
    ACTIVE ([dvDECK,nOFFSET_FB+STOP_FB]
            OR [dvDECK,nOFFSET_FB+FFWD_FB]
            OR [dvDECK,nOFFSET_FB+REW_FB]
            OR (dcTRANSPORTS[6].CHANNEL
                AND ([dvDECK,nOFFSET_FB+PLAY_FB]
                    OR [dvDECK,nOFFSET_FB+SREV_FB]
                    OR [dvDECK,nOFFSET_FB+SFWD_FB]))) :
    {
      CANCEL_WAIT 'VCR1 REW TO STOP'
      CANCEL_WAIT 'VCR1 PAUSE TO STOP'
      CANCEL_WAIT 'VCR1 SREV TO STOP'
      CALL 'ALL OFF'
      MIN_TO [dvDECK,nOFFSET_FN+FFWD]
      CALL 'FEEDBACK' (FFWD)
    }
    ACTIVE (dcTRANSPORTS[6].CHANNEL=NO_BUTTON
            AND ([dvDECK,nOFFSET_FB+PLAY_FB]
                OR [dvDECK,nOFFSET_FB+SREV_FB]
                OR [dvDECK,nOFFSET_FB+SFWD_FB])) :
    {
      CANCEL_WAIT 'VCR1 REW TO STOP'
      CANCEL_WAIT 'VCR1 PAUSE TO STOP'
      CANCEL_WAIT 'VCR1 SREV TO STOP'
      CALL 'ALL OFF'
      MIN_TO [dvDECK,nOFFSET_FN+SFWD]
      CALL 'FEEDBACK' (SFWD)
    }
  }
}

CASE SFWD:
{
  IF ([dvDECK,nOFFSET_FB+PLAY_FB]
      OR [dvDECK,nOFFSET_FB+STOP_FB]
      OR [dvDECK,nOFFSET_FB+REW_FB]
      OR [dvDECK,nOFFSET_FB+FFWD_FB]
      OR [dvDECK,nOFFSET_FB+SREV_FB]
      OR [dvDECK,nOFFSET_FB+SFWD_FB])
  {
    CANCEL_WAIT 'VCR1 REW TO STOP'
    CANCEL_WAIT 'VCR1 PAUSE TO STOP'
    CANCEL_WAIT 'VCR1 SREV TO STOP'
    CALL 'ALL OFF'
    MIN_TO [dvDECK,nOFFSET_FN+SFWD]
    CALL 'FEEDBACK' (SFWD)
  }
}

CASE REW:
{
  SELECT
  {
    ACTIVE ([dvDECK,nOFFSET_FB+STOP_FB]
            OR [dvDECK,nOFFSET_FB+FFWD_FB]
            OR [dvDECK,nOFFSET_FB+REW_FB]
            OR (dcTRANSPORTS[7].CHANNEL
                AND ([dvDECK,nOFFSET_FB+PLAY_FB]
                    OR [dvDECK,nOFFSET_FB+SREV_FB]
                    OR [dvDECK,nOFFSET_FB+SFWD_FB]))) :
    {
      CANCEL_WAIT 'VCR1 REW TO STOP'
      CANCEL_WAIT 'VCR1 PAUSE TO STOP'
      CANCEL_WAIT 'VCR1 SREV TO STOP'
      WAIT VCR1_REW_TO_STOP 'VCR1 REW TO STOP'
      SYSTEM_CALL 'FUNCTION' (dvDECK,STOP,nFIRST)
      CALL 'ALL OFF'
      MIN_TO [dvDECK,nOFFSET_FN+REW]
      CALL 'FEEDBACK' (REW)
    }
  }
}

```

```

    }
ACTIVE (dcTRANSPORTS[7].CHANNEL=NO_BUTTON
AND ([dvDECK,nOFFSET_FB+PLAY_FB]
OR [dvDECK,nOFFSET_FB+SREV_FB]
OR [dvDECK,nOFFSET_FB+SFWD_FB])):
{
    CANCEL_WAIT 'VCR1 REW TO STOP'
    CANCEL_WAIT 'VCR1 PAUSE TO STOP'
    CANCEL_WAIT 'VCR1 SREV TO STOP'
    WAIT VCR1_SREV_TO_STOP 'VCR1 SREV TO STOP'
    SYSTEM_CALL 'FUNCTION' (dvDECK,STOP,nFIRST)
    CALL 'ALL OFF'
    MIN_TO [dvDECK,nOFFSET_FN+SREV]
    CALL 'FEEDBACK' (SREV)
}
}
}

CASE SREV:
{
    IF ([dvDECK,nOFFSET_FB+PLAY_FB]
OR [dvDECK,nOFFSET_FB+STOP_FB]
OR [dvDECK,nOFFSET_FB+REW_FB]
OR [dvDECK,nOFFSET_FB+FFWD_FB]
OR [dvDECK,nOFFSET_FB+SREV_FB]
OR [dvDECK,nOFFSET_FB+SFWD_FB])
{
    CANCEL_WAIT 'VCR1 REW TO STOP'
    CANCEL_WAIT 'VCR1 PAUSE TO STOP'
    CANCEL_WAIT 'VCR1 SREV TO STOP'
    WAIT VCR1_SREV_TO_STOP 'VCR1 SREV TO STOP'
    SYSTEM_CALL 'FUNCTION' (dvDECK,STOP,nFIRST)
    CALL 'ALL OFF'
    MIN_TO [dvDECK,nOFFSET_FN+SREV]
    CALL 'FEEDBACK' (SREV)
}
}

CASE REC:
{
    IF ([dvDECK,nOFFSET_FB+STOP_FB]
OR [dvDECK,nOFFSET_FB+REC_FB])
{
    CANCEL_WAIT 'VCR1 REW TO STOP'
    CANCEL_WAIT 'VCR1 PAUSE TO STOP'
    CANCEL_WAIT 'VCR1 SREV TO STOP'
    CALL 'ALL OFF'
    MIN_TO [dvDECK,nOFFSET_FN+REC]
    CALL 'FEEDBACK' (REC)
}
}
}
}

(*****
*           THE ACTUAL PROGRAM GOES BELOW           *
*****)

DEFINE_PROGRAM

[dcTRANSPORTS[1]] = [dvDECK,nOFFSET_FB+PLAY_FB]
[dcTRANSPORTS[2]] = [dvDECK,nOFFSET_FB+STOP_FB]
[dcTRANSPORTS[3]] = [dvDECK,nOFFSET_FB+PAUSE_FB]
[dcTRANSPORTS[4]] = ([dvDECK,nOFFSET_FB+FFWD_FB] OR (dcTRANSPORTS[6].CHANNEL=NO_BUTTON AND
[dvDECK,nOFFSET_FB+SFWD_FB]))
[dcTRANSPORTS[5]] = ([dvDECK,nOFFSET_FB+REW_FB] OR (dcTRANSPORTS[7].CHANNEL=NO_BUTTON AND
[dvDECK,nOFFSET_FB+SREV_FB]))
[dcTRANSPORTS[6]] = [dvDECK,nOFFSET_FB+SFWD_FB]
[dcTRANSPORTS[7]] = [dvDECK,nOFFSET_FB+SREV_FB]
[dcTRANSPORTS[8]] = ([dvDECK,nOFFSET_FB+REC_FB] AND (![dvDECK,nOFFSET_FB+PAUSE_FB]))

(*****
*           END OF PROGRAM                           *
*           DO NOT PUT ANY CODE BELOW THIS COMMENT   *
*****)

```

Using a Module in a Program

To use a module in a program, you must declare it using the `DEFINE_MODULE` keyword. This tells the NetLinx compiler to add the module to the program, effectively merging the module's event handling and mainline code with the containing program (or module). In other words, the program will have one event table and one mainline routine consisting of code from the main program and all modules declared using the `DEFINE_MODULE` statement.

Technically, modules can contain declarations to other modules, provided that no circular references are involved. However, because different instances of the same module must not be separated by instances of a different module, it is highly recommended that you do not declare modules from within other modules - if you have multiple declarations of the parent module they will then be separated by the declarations of the child module.

FIG. 3 demonstrates how a NetLinx module is incorporated into a main program. In this example, the main program has no event table or mainline code.

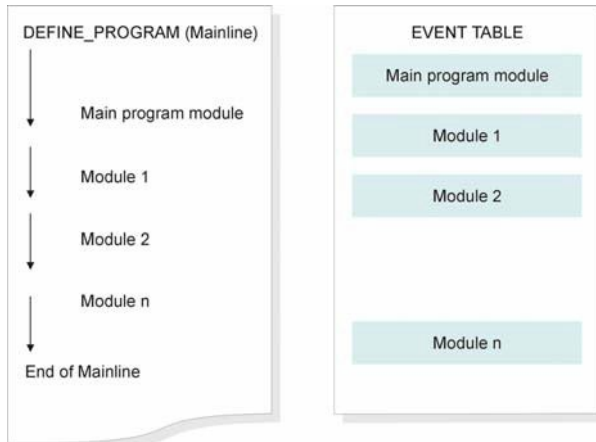

FIG. 3 Mainline and Event Table Organization

```
PROGRAM_NAME='ModuleExampleTest'

(*{{PS_SOURCE_INFO (PROGRAM STATS)
                                     *)

(*****
(* ORPHAN_FILE_PLATFORM: 1
*****
*)}PS_SOURCE_INFO
*)

(*****
(* DEVICE NUMBER DEFINITIONS GO BELOW
*****
*)

DEFINE_DEVICE
dvVCR = 1:7:0
dvTP = 128:1:0

(*****
(* VARIABLE DEFINITIONS GO BELOW
*****
*)

DEFINE_VARIABLE
VOLATILE
DEVCHAN dcTRANSPORTS[] = {
    { dvTP,1 }, { dvTP,2 }, { dvTP,3 }, { dvTP,4 },
    { dvTP,5 }, { dvTP,6 }, { dvTP,7 }, { dvTP,8 }
}

VOLATILE
INTEGER nVCR_FIRST = 0
                                     (*****
(* MODULE CODE GOES BELOW
*****
*)

DEFINE_MODULE 'ModuleExample' mdlVCR(dvVCR,dcTRANSPORTS,nVCR_FIRST)

(*****
(* END OF PROGRAM
(* DO NOT PUT ANY CODE BELOW THIS COMMENT
*****
*)
```

Module Keywords

NetLinx supports the following Module keywords:

Module Keywords	
DEFINE_MODULE	<p>This keyword declares a module that will be used by either the main program or another module. It is the counterpart to the MODULE_NAME entry that appears as part of the implementation of the module.</p> <pre>DEFINE_MODULE '<module name>' InstanceName (<parameter list>)</pre> <p>Parameters:</p> <ul style="list-style-type: none"> <module name>: The name of the module as specified in the MODULE_NAME statement in the module implementation file. InstanceName: The name to assign to the instance of the module. <parameter list>: The list of parameters available to the module.
DUET_MEM_SIZE_GET	<p>Display the amount of memory allocated for Duet Java pool.</p> <p>This is the current Java memory heap size as measured in Megabytes.</p> <p>An example is a value of 5 = 5 MB.</p>
DUET_MEM_SIZE_SET	<p>Set the amount of memory allocated for Duet Java pool. This is the current Java memory heap size as measured in Megabytes. This feature is used so that if a NetLinx program requires a certain size of memory be allotted for its currently used Duet Modules, it can be reserved on the target Master.</p> <p>Valid values are:</p> <p>2 - 8 for 32MB systems 2 - 36 for 64MB systems</p> <p>This setting does not take effect until the next reboot.</p> <p>NOTE: "DUET_MEM_SIZE_SET(int)" should call REBOOT() following a set.</p>
MODULE_NAME	<p>This keyword introduces the definition of a module. It must appear on the first line of the module implementation file.</p> <pre>MODULE_NAME = '<module name>' (<parameter list>)</pre> <p>See DEFINE_MODULE, on page 117, for more information.</p>

Operator Keywords

Overview

An *Operator* is a character or group of characters that performs a specific mathematical or relational function. Each operator type is described below.

Arithmetic Operators

Arithmetic operators create a numeric value from one or more operations such as addition, multiplication, and division.

Arithmetic Operators	
Operator	Function
+	Addition
-	Subtraction
*	Multiplication
/	Division
%	Modulo (remainder after division)

Relational Operators

A relational operator is a conditional statement; it tells NetLinx whether to execute a particular function(s) in the program.

Relational Operators	
Operator	Function
<	Less Than
>	Greater Than
=	Equal To
==	Equal To
<=	Less Than or Equal To
>=	Greater Than or Equal To
<>	Not Equal To

Logical Operators

Logical operators compare two conditions or, in the case of **NOT**, invert one condition. A true or false result is produced.

Logical Operators		
Operator	Function	Keyword
&&	Logical And	AND (see page 119)
	Logical Or	OR (see page 119)
^^	Logical Xor	XOR (see page 119)
!	Logical Not	NOT (see page 119)

Bitwise Operators

Bitwise operators are keywords or symbols that perform a bit-by-bit operation between two items.

Bitwise Operators		
Operator	Function	Keyword
&	Bitwise And	BAND (see page 119)
	Bitwise Or	BOR (see page 119)
^	Bitwise Xor	BXOR (see page 119)
~	Bitwise Not	BNOT (see page 119)
<<	Shift Left	LSHIFT (see page 119)
>>	Shift Right	RSHIFT (see page 119)

Assignment Operators

The assignment operators may appear only once in a single NetLinx statement.

Assignment Operators	
Operator	Function
=	Assignment
++	Increment by 1
--	Decrement by 1

The following rules apply to the use of assignment operators:

- The "=" operator may be used to assign:
 - Expressions to intrinsic type variables (see the *Data Type Keywords* section on page 55)
 - Arrays to other arrays of matching size and type
 - Structures to other structures of the same type

- The "++" and "--" operators are statements and cannot appear within expressions. For example:

```
FOR (I=1; I<10; I++) // Legal
I = j++;           // Illegal
```

NOTE: Refer to the Structure Keywords section on page 130 for information on structures.

Operator Precedence

The table below shows the inherent precedence assigned to the operators.

Operator Precedence		
Level	Operators	Associativity
1	! ~	Left To Right
2	* / %	Left To Right
3	<< >>	Left To Right
4	+ -	Left To Right
5	< <= > >= = == <>	Left To Right
6	& ^	Left To Right
7	&& ^^	Left To Right

NOTE: As noted in the chart, the NOT(!) operator has the highest precedence in NetLinx systems but the lowest precedence in Access systems. Access programs that are converted to NetLinx may exhibit logic problems if they use statements that combine NOT(!) and other operators. Contact AMX Technical Support for help resolving these issues.

Operator Keywords

NetLinx supports the following Operators:

Operator Keywords	
AND (&&)	This logical operator evaluates two logical conditions. Both conditions must be true for the entire expression to be true.
BAND (&)	This operator performs a bitwise AND on two data items, which can be constants or variables.
BNOT (~)	This operator performs a bitwise NOT on a constant or variable.
BOR ()	This operator performs a bitwise OR on two data items, which can be constants or variables.
BXOR (^)	This operator performs a bitwise XOR operation between two data items, which can be constants or variables.
LSHIFT	This keyword causes the bits in the associated integer field to be shifted left. This has the effect of multiplying by 2 ⁿ , where n is the number of bit positions to shift. The symbol << is equivalent to LSHIFT. For example: INT2 = INT1 LSHIFT 2 is equivalent to: INT2 = INT1 << 2 Both statements shift INT1 left two positions. Either statement could be replaced with the following: INT2 = INT1 * 4
MOD (%)	This keyword is used to generate the remainder of a division function. You cannot take the mod of an integer without first loading the value into a variable. For example: VRAM_LSB = ((2 % 16)+\$30) (* does not work *) However, ID = 2 OTHER = 16 VRAM_LSB = ((ID % OTHER) + \$30) (* works *)
NOT (!)	This keyword is used to negate a given expression. IF (NOT (X > 10)) { // statements to execute if X <= 10 }
OR ()	This keyword evaluates two conditions. If one or both conditions are true, the entire expression evaluates to true.
RSHIFT	This keyword causes the bits in the associated value field to be shifted right. This has the effect of dividing by 2 ⁿ where n is the number of bit positions to shift. The symbol >> is equivalent to RSHIFT. For example: INT2 = INT1 RSHIFT 2 is equivalent to: INT2 = INT1 >> 2 Both statements shift INT1 right two positions. Either statement could be replaced with: INT2 = INT1 / 4
XOR (^)	This keyword evaluates two conditions. One and only one condition can be true for the entire expression to be true.

Port Keywords

The NetLinx programming language supports the following Port keywords:

Port Keywords	
DYNAMIC_POLLED_PORT	Designates a NetLinx serial port that should be polled for dynamic device detection. This API must be called for each serial port that can dynamically have a device plugged into it. <code>DYNAMIC_POLLED_PORT (DEV netlinxDevice)</code>
FIRST_LOCAL_PORT	This keyword contains the lowest number that may be assigned as a local port number.
STATIC_PORT_BINDING	Designates an application device along with its SDK class and the physical interface it is bound to.

Push and Release Keywords

NetLinx supports the following PUSH and RELEASE keywords:

PUSH and RELEASE Keywords	
DO_PUSH	<p>This keyword causes an input change from OFF to ON to occur on a specified device-channel without the device-channel being activated by external means. To prevent the program from stalling mainline too long, there is a 0.5 second timeout on DO_PUSH.</p> <p>DO_PUSH defaults to a 0.5 second push on a channel before issuing a DO_RELEASE for you (unless another DO_PUSH is executed for the same channel). NetLinx will forcibly exit the DO_PUSH after 0.5 seconds, regardless of the operation it is executing. If the channel is already ON, no event is generated.</p> <p>NOTE: <i>The timeout feature is used to prevent un-released pushes and out of control ramping.</i></p> <pre>DO_PUSH (DEVICE, CHANNEL)</pre>
DO_PUSH_TIMED	<p>Similar to DO_PUSH, except DO_PUSH_TIMED lets you specify the timeout, so you can control the length of time that will pass before the automatic DO_RELEASE is generated.</p> <pre>DO_PUSH_TIMED (DEV Device, INTEGER Channel, LONG Timeout)</pre> <p>Parameters:</p> <ul style="list-style-type: none"> • Device: The device to PUSH. • Channel: The channel to PUSH. • Timeout: The time (in 1/10ths of seconds) the PUSH remains active. If zero is specified as the timeout then the timeout is 0.5 seconds. If DO_PUSH_TIMED_INFINITE is specified as the timeout then the push never times out. <pre>DO_PUSH_TIMED (dvTouchPanel, 5, 10) // push button 5 for 1.0S</pre>
DO_RELEASE	<p>This keyword causes an input change from ON to OFF to occur on a specified device and channel without the channel being deactivated by external means. If the channel is already OFF, no event is generated.</p> <pre>DO_RELEASE (DEVICE, CHANNEL)</pre>
MIN_TO	<p>This keyword operates just like the TO keyword, except that the specified channel or variable stays on for a minimum length of time, even if the corresponding channel is released. The minimum length of time is set by SET_PULSE_TIME. MIN_TO follows the same conditions of operation as the TO keyword.</p> <p>See SET_PULSE_TIME, on page 123, for more information.</p>
PUSH	<p>This keyword declares a block of code to be executed when a push event is received for the associated device and channel. An example PUSH statement is shown below:</p> <pre>PUSH [DEVICE, CHANNEL] PUSH [DEVCHAN[]]</pre> <pre>{</pre> <pre> // statements</pre> <pre>}</pre> <p>This keyword also defines a section in the BUTTON_EVENT handler for processing PUSH events.</p>
PUSH_CHANNEL	<p>This keyword contains the channel number that was just turned on due to an input change. The value remains valid for one pass through mainline. The inactive state of this variable is all fields equal to zero.</p>
PUSH_DEVCHAN	<p>This keyword contains the device-channel (a DEVCHAN structure) that was just turned on due to an input change. Individual fields of this DEVCHAN structure can be accessed using dot-operator syntax, as shown below:</p> <pre>PUSH_DEVCHAN.Device</pre> <pre>PUSH_DEVCHAN.Device.Number</pre> <pre>PUSH_DEVCHAN.Device.Port</pre> <pre>PUSH_DEVCHAN.Device.System</pre> <pre>PUSH_DEVCHAN.Channel</pre> <ul style="list-style-type: none"> • These fields remain valid for one pass through mainline. • The inactive state of this variable is <i>all fields equal to zero</i>.
PUSH_DEVICE	<p>This keyword contains the number of the device that was just turned on due to an input change. The value remains valid for one pass through mainline. The inactive state of this variable is all fields equal to zero.</p>
RELEASE	<p>This keyword declares a block of code to be executed when a release event is received for the associated device and channel.</p> <pre>RELEASE [DEVICE, CHANNEL]</pre> <pre>RELEASE [DEVCHAN[]]</pre> <pre>{</pre> <pre> // statements</pre> <pre>}</pre> <p>This keyword also defines a section in a BUTTON_EVENT handler for processing RELEASE events.</p>
RELEASE_CHANNEL	<p>This keyword contains the number of the channel that was just turned off due to an input change.</p> <ul style="list-style-type: none"> • The value remains valid for one pass through mainline. • The inactive state of this variable is <i>all fields equal to zero</i>.
RELEASE_DEVCHAN	<p>This keyword contains the device-channel (a DEVCHAN structure) that was just turned off due to an input change. Individual fields of this DEVCHAN structure can be accessed using dot-operator syntax, as shown below:</p> <pre>RELEASE_DEVCHAN.Device</pre> <pre>RELEASE_DEVCHAN.Device.Number</pre> <pre>RELEASE_DEVCHAN.Device.Port</pre> <pre>RELEASE_DEVCHAN.Device.System</pre> <pre>RELEASE_DEVCHAN.Channel</pre> <ul style="list-style-type: none"> • These fields remain valid for one pass through mainline. • The inactive state of this variable is all fields equal to zero.
RELEASE_DEVICE	<p>This system variable contains the number of the device associated with the channel that was just turned off due to an input change.</p> <ul style="list-style-type: none"> • The value remains valid for one pass through mainline. • The inactive state of this variable is all fields equal to zero.

PUSH and RELEASE Keywords (Cont.)

TO	<p>This keyword activates a channel or variable for as long as the corresponding channel of its PUSH statement is activated. When the channel referenced by the PUSH statement changes from off to on, the TO command starts activating the associated channel or variable. When the channel is released, the TO command stops activating of the channel or variable. Therefore, a TO statement must be found underneath a PUSH statement only.</p> <p>The syntax is shown below:</p> <pre>TO [DEVICE,CHANNEL]TO [(DEVCHAN[])]TO [Variable]</pre> <p>Several conditions apply to the use of the TO command:</p> <ul style="list-style-type: none">• It must be used only below a PUSH statement.• It cannot be used as part of a set of WAIT statements.• It cannot be placed in the DEFINE_START section. <p>The channel or variable will act under the rules set by DEFINE_LATCHING, DEFINE_MUTUALLY_EXCLUSIVE, and DEFINE_TOGGLING.</p>
-----------	---

SET Keywords

NetLinx supports the following SET keywords:

SET Keywords	
SET_DNS_LIST	See page 100.
SET_IP_ADDRESS	See page 100.
SET_LENGTH_ARRAY	See page 32.
SET_LENGTH_STRING	See page 129.
SET_OUTDOOR_TEMPERATURE	<p>This function establishes the value for the outdoor temperature.</p> <ul style="list-style-type: none"> This value is broadcast to all devices periodically. A value of 32768 indicates that no outdoor temperature is available. <pre>SET_OUTDOOR_TEMPERATURE(INTEGER Temp)</pre> <p>Parameters:</p> <ul style="list-style-type: none"> Temp: The outdoor temperature as it shall be displayed. It is up to the programmer to provide the correct temperature scale whether it is Celsius or Fahrenheit. <pre>SET_OUTDOOR_TEMPERATURE (32) // show 32 degrees</pre>
SET_PULSE_TIME	<p>This function sets the PULSE time in 1/10th second units. The default PULSE time is 5 (0.5 seconds).</p> <pre>SET_PULSE_TIME (TIME)</pre>
PULSE	<p>This keyword turns a channel or variable on for the length of time set by the function SET_PULSE_TIME. Once the pulse time elapses, the channel or variable is turned off.</p> <pre>PULSE [DEVICE, CHANNEL] PULSE [DEVCHAN[]] PULSE [Variable]</pre>
SET_SYSTEM_NUMBER	<p>Sets the system number of the NetLinx master. The new system number will take effect after the system has been rebooted.</p> <pre>SLONG SET_SYSTEM_NUMBER (INTEGER newSystemNum)</pre> <p>Parameters:</p> <ul style="list-style-type: none"> newSystemNum: Desired new system number <p>Result:</p> <ul style="list-style-type: none"> 0: Operation was successful. -1: System number is invalid. -2: Assignment of system number causes conflict. <p>This function only affects the master's system number, not the system number of any attached devices. Therefore, any devices with pre-programmed system numbers will no longer communicate with this master.</p> <pre>SET_SYSTEM_NUMBER (3) // set new system number</pre>
SET_TIMER	<p>This keyword resets the system timer. The system timer counts up in 1/10th second units. The value passed to this function (TIME) may be any unsigned 32-bit variable or constant. This provides a timer with a maximum range of over 13 years.</p> <pre>SET_TIMER (TIME)</pre> <p>NOTE: <i>The system timer is reset to zero on power up.</i></p>
SET_VIRTUAL_CHANNEL_COUNT	<p>This function lets the programmer override the default number of channels that a virtual device port maintains. By default every virtual device port maintains the state of channels 1-255 inclusive.</p> <pre>SET_VIRTUAL_CHANNEL_COUNT(DEV Device, INTEGER Count)</pre> <p>Parameters:</p> <ul style="list-style-type: none"> Device: The virtual device port to modify. Count: The number of channels that the specified virtual device port should maintain. <pre>SET_VIRTUAL_CHANNEL_COUNT (dvVirtual,1024) // 1024 channels</pre>
SET_VIRTUAL_LEVEL_COUNT	<p>This function lets the programmer override the default number of levels that a virtual device port maintains. By default, every virtual device port maintains the state of levels 1-8 inclusive.</p> <pre>SET_VIRTUAL_LEVEL_COUNT (DEV Device, INTEGER Count)</pre> <p>Parameters:</p> <ul style="list-style-type: none"> Device: The virtual device port to modify. Count: The number of levels that the specified virtual device port should maintain. <pre>SET_VIRTUAL_LEVEL_COUNT (dvVirtual,10) // make it have 10 levels</pre>
SET_VIRTUAL_PORT_COUNT	<p>This function lets the programmer override the default number of ports that a virtual device maintains. By default every virtual device maintains the state of a single port (port 1).</p> <pre>SET_VIRTUAL_PORT_COUNT(DEV Device, INTEGER Count)</pre> <p>Parameters:</p> <ul style="list-style-type: none"> Device: The virtual device to modify. Count: The number of ports that the specified virtual device should maintain. <pre>SET_VIRTUAL_PORT_COUNT (dvVirtual,2) // 2 ports</pre>

SMTP Keywords

Overview

SMTP functionality is supported by NetLinx Controller firmware version 4 or higher. NetLinx supports the following SMTP keywords:

SMTP Keywords	
SMTP_SERVER_CONFIG_SET	<p>Set a configuration value for the current SMTP server.</p> <ul style="list-style-type: none"> SMTP Server configuration will be retained between boots of the master. Once the server configuration values have been set, email can be sent using the SMTP_SEND() API. <p>Syntax: SMTP_SERVER_CONFIG_SET(CONSTANT CHAR CONFIG_NAME, CONSTANT CHAR CONFIG_VALUE)</p> <p>Where CONFIG_NAME is one of the following:</p> <ul style="list-style-type: none"> SMTP_ADDRESS - Used to set the address of the SMTP server (e.g. 'mail.acme.com') SMTP_PORT_NUMBER - Used to set the IP port number to connect to on the SMTP server (e.g. '25'). NOTE: Supplying a port number of 0 means "use the best default port" which would imply use 25 which is the SMTP well-known port. SMTP_USERNAME - Used to set the username for server authentication. If username length is set to 0, authentication is not attempted when connecting to the server. SMTP_PASSWORD - Used to set the password for server authentication. If password length is set to 0, authentication is still attempted but a zero-length password (NULL_STR) is sent. SMTP_FROM - Used to set the 'Mail-From:' field in outgoing emails. SMTP_REQUIRE_TLS - Used to set whether TLS authentication security should be required when connecting to the server. Valid values are SMTP_TLS_TRUE and SMTP_TLS_FALSE. <p>Example: SMTP_SERVER_CONFIG_SET(SMTP_ADDRESS, 'mail.acme.com') SMTP_SERVER_CONFIG_SET(SMTP_PORT_NUMBER, '25') SMTP_SERVER_CONFIG_SET(SMTP_USERNAME, 'john.doe@acme.com') SMTP_SERVER_CONFIG_SET(SMTP_PASSWORD, 'mypassword') SMTP_SERVER_CONFIG_SET(SMTP_FROM, 'john.doe@acme.com') SMTP_SERVER_CONFIG_SET(SMTP_REQUIRE_TLS, SMTP_TLS_TRUE)</p>
SMTP_SERVER_CONFIG_GET	<p>Get a configuration value for the current SMTP server.</p> <p>Syntax: CHAR[] SMTP_SERVER_CONFIG_GET(CONSTANT CHAR CONFIG_NAME)</p> <p>Where CONFIG_NAME is one of the following:</p> <ul style="list-style-type: none"> SMTP_ADDRESS - Used to get the address of the SMTP server (e.g. 'mail.acme.com'). SMTP_PORT_NUMBER - Used to get the IP port number to connect to on the SMTP server (e.g. '25'). NOTE: Supplying a port number of 0 means "use the best default port" which would imply the use of port 25 which is the SMTP well-known port. SMTP_FROM - Used to set the 'Mail-From:' field in outgoing emails. SMTP_REQUIRE_TLS - Used to set whether TLS authentication security should be required when connecting to the server. Valid return values are SMTP_TLS_TRUE and SMTP_TLS_FALSE <p>NOTE: Query of SMTP_USERNAME and SMTP_PASSWORD is disabled for security reasons.</p> <p>Example: CURRENT_ADDRESS = SMTP_SERVER_CONFIG_GET(SMTP_ADDRESS) CURRENT_PORT = SMTP_SERVER_CONFIG_GET(SMTP_PORT_NUMBER) CURRENT_FROM = SMTP_SERVER_CONFIG_GET(SMTP_FROM) CURRENT_TLS = SMTP_SERVER_CONFIG_GET(SMTP_REQUIRE_TLS)</p>

SMTP Keywords (Cont.)**SMTP_SEND**

Sends an email to a single destination. It returns an identifier associated with the email event. The email is sent asynchronously by the on-board SMTP client. If the mail transmission fails, an ONERROR DATA event will be sent to the supplied status DPS with DATA.NUMBER set to the error code and DATA.TEXT set to the string representation of the email identifier.

Syntax:

```
SINTEGER SMTP_SEND (DEV DPS, CONSTANT CHAR TO_ADDRESS[], CONSTANT CHAR SUBJECT[],
CONSTANT CHAR BODY[], CONSTANT CHAR TEXT_ATTACHMENT[])
```

Where:

- DPS is a DEV to receive asynchronous send status
- TO_ADDRESS is a string containing the email address of the destination. String must be less than 127 characters.
- SUBJECT is a string containing the email subject line
- BODY is a string containing the email body text
- TEXT_ATTACHMENT is a string containing the filename of a text file to be attached to the email. Filename must be less than 256 characters and file size must be under 65536 bytes. Can be specified as NULL_STR when no attachment is desired.

Example:

```
MAIL_IDX1 = SMTP_SEND (0:3:0, 'john.doe@acme.com', 'Mail Subject', 'This is the mail
text', 'attachment.txt')
MAIL_IDX2 = SMTP_SEND (0:3:0, 'jane.doe@acme.com', 'Mail Alert',
'This is an email alert!', NULL_STR)
DEFINE_EVENT
DATA_EVENT [0:3:0]
{
  ONERROR
  {
    SEND_STRING 0, "Email send failed: idx=',DATA.TEXT,'error=', ITOA(DATA.NUMBER) "
  }
}
```

Error codes returned in the ONERROR event:

- 1 = Malformed data
- 2 = Not enough memory
- 3 = Mail server is unreachable
- 4 = Mail server authorization failure
- 5 = SMTP Protocol error
- 6 = Mail server is full

String Keywords

Overview

A *string* is an array of characters of known length. This length may be less than the dimensioned length. For example:

```
DEFINE_VARIABLE
CHAR MyString[32]
INTEGER StrLen

DEFINE_START
MyString = 'STOP'
StrLen = LENGTH_STRING(MyString)
```

In the example above, `StrLen` holds the value 4, the length of `MyString`. The length of `MyString` can range from 0 to 32. If an attempt is made to assign a string longer than the capacity of the destination string, the copied string is truncated to fit. The string length is implicitly set when a string literal, string expression, or variable is assigned to the string. The function `SET_LENGTH_STRING` can be used to explicitly set the length of a string to any arbitrary length between 0 and the dimension of the character array. For example:

```
SET_LENGTH_STRING(MyString, 3)
```

causes the contents of `MyString` to read 'STO', even though the character 'P' still resides in `MYSTRING[4]`.

String Expressions

A *string expression* is a string enclosed in double quotes containing a series of constants and/or variables evaluated at run-time to form a string result. String expressions can contain up to 16000 characters consisting of string literals, variables, arrays, and ASCII values between 0 and 255. For example:

```
CHAR StrExp[6]
StrExp = "STOP, 25, 'OFF', X"
```

In the example above, the string expression contains the constant `STOP`, the value 25, the string literal `'OFF'`, and the variable `X`. Assuming `STOP` is 2 and `X` = 5, the string expression will evaluate to "2, 25, 'OFF', 5".

Wide Strings

The *wide string* (wide character string data type) is provided for dealing with Unicode fonts, which use 16-bit character codes, used for many Far-Eastern fonts (instead of the standard 8-bit codes used with most Western fonts). Here's a syntax sample for a wide character string:

```
WIDECHAR WChar[40]
```

The statement above declares a wide character string containing 40 elements, for a total of 80 bytes. A wide character string can be used in the same manner as other character strings. It maintains a length field that can be retrieved using `LENGTH_STRING` and set using `SET_LENGTH_STRING`. For example:

```
WIDECHAR StrExp[6]
INTEGER StrLen

StrExp = {STOP, 500, 'OFF', X}
StrLen = LENGTH_STRING(StrExp)
```

In the example above, if `STOP` is 2 and `X` is a wide character whose value is 1000, the string expression will evaluate to "2, 500, 79, 70, 70, 1000" and `StrLen` is 6. Each array element can now assume a value of up to 65,535, rather than the limit of 255 imposed by the standard character string. A `CHAR` string may be assigned or compared to a wide character string. For example:

```
WChar = 'FFWD'
- or -
IF (WChar = 'REV')
{
    (* statements *)
}
```

Each 8-bit character in the `CHAR` string is converted to 16-bit before the assignment or comparison operation is performed.

STRING Keywords

NetLinx supports the following STRING keywords:

STRING Keywords	
CHARD	<p>Sets the delay between all transmitted characters to that specified in 100-microsecond increments.</p> <p>The syntax: CHARD-<time in 100 microsecond increments></p> <p>Example: SEND_COMMAND device, 'CHARD-100'</p> <p>Sets a 10mS delay between all transmitted characters.</p>
CHARDM	<p>Sets the delay between all transmitted characters to that specified in 1-millisecond increments.</p> <p>The syntax: CHARDM-<time in 1 millisecond increments></p> <p>Example: SEND_COMMAND device, 'CHARDM-100'</p> <p>Sets a 10 mS delay between all transmitted characters.</p>
COMPARE_STRING	<p>This keyword compares two character strings. If either string contains a '?' character, the matching character in the other string is not compared. The '?' is equivalent to a wildcard.</p> <p>Example: DEFINE_LIBRARY_FUNCTION LONG COMPARE_STRING (CHAR A[], CHAR B[])</p> <p>Here is some useful debugging code:</p> <pre>tstStr = 'ALEXERICRYAN' ulError = COMPARE_STRING (tstStr, 'ALEX') if (ulError == 0) SEND_STRING dvDebug, 'ALEXERICRYAN != ALEX' else SEND_STRING dvDebug, 'ALEXERICRYAN == ALEX... BAD!' tstStr = 'ALEXERICRYAN' ulError = COMPARE_STRING (tstStr, 'ALEXERICRYAN') if (ulError == 0) SEND_STRING dvDebug, 'ALEXERICRYAN != ALEXERICRYAN...BAD!' else SEND_STRING dvDebug, 'ALEXERICRYAN == ALEXERICRYAN' tstStr = 'ALEXERICRYAN' ulError = COMPARE_STRING (tstStr, 'ALEX????RYAN') if (ulError == 0) SEND_STRING dvDebug, 'ALEXERICRYAN != ALEX????RYAN...BAD!' else SEND_STRING dvDebug, 'ALEXERICRYAN == ALEX????RYAN'</pre> <p>Another example of a use for this feature is if you want an event to occur every hour. You would enter a time string that would contain a '??:00;00' (hours/minute/sec) for the recurring event that in this case would occur every hour.</p> <p>Result: The returned result can only be True (1) or False (0).</p> <ul style="list-style-type: none"> • 0 = the strings don't match • 1 = the strings are the same
FIND_STRING	<p>This function searches through a string for a specified sequence of characters.</p> <pre>INTEGER FIND_STRING (CHAR STRING[], CHAR Seq[], INTEGER Start)INTEGER FIND_STRING (WIDECHAR STRING[], WIDECHAR Seq[], INTEGER Start)</pre> <p>Parameters:</p> <ul style="list-style-type: none"> • STRING: The string of character to search. • Seq: The sequence of characters to search for. • Start: The starting character position for the search. <p>Result: A 16-bit unsigned integer representing the character location of Seq in STRING. If the character string is found at the beginning of the string, this function returns 1; any error condition returns 0.</p> <pre>POS = FIND_STRING (STRING, 'ABC', 1)</pre>
LEFT_STRING	<p>This function returns the specified number of characters from the beginning of a string.</p> <pre>CHAR[] LEFT_STRING (CHAR STRING[], LONG Count) WIDECHAR[] LEFT_STRING (WIDECHAR STRING[], LONG Count)</pre> <p>Parameters:</p> <ul style="list-style-type: none"> • STRING: The string from which to extract the characters. • Count: The number of character to copy from the beginning of the string. <p>The result is a string containing a copy of the first Count characters from STRING.</p> <pre>STRING = 'ABCDEFGF'Substr = LEFT_STRING (STRING, 3) // Substr = 'ABC'</pre>

STRING Keywords (Cont.)	
LENGTH_STRING	<p>This function returns the length of a CHAR or WIDECHAR string. This function is retained for compatibility with previous versions of Axxess and provides the same information as LENGTH_ARRAY.</p> <pre>LONG LENGTH_STRING (CHAR STRING[]) LONG LENGTH_STRING (WIDECHAR STRING[])</pre> <p>Parameters:</p> <ul style="list-style-type: none"> • STRING: The input character string. <p>The result is the length of STRING. The string length can be set implicitly through a literal or variable string assignment or explicitly by calling SET_LENGTH_STRING.</p> <p>For example:</p> <pre>IF (LENGTH_STRING(STRING) > 0) { // process string }</pre>
LOWER_STRING	<p>This function changes all alphabetic characters in the specified string to lower case.</p> <pre>CHAR[] LOWER_STRING (CHAR STRING[]) WIDECHAR[] LOWER_STRING (WIDECHAR STRING[])</pre> <p>Parameters:</p> <ul style="list-style-type: none"> • STRING: The character string to convert to lower case. <p>The result is the converted character string.</p> <pre>LCString = LOWER_STRING(STRING)</pre>
MAX_LENGTH_STRING	<p>This function returns the dimensioned length of a CHAR or WIDECHAR string. This function is retained for compatibility with previous versions of Axxess. It provides the same information as MAX_LENGTH_ARRAY (see page 32).</p> <pre>LONG MAX_LENGTH_STRING (CHAR STRING[]) LONG MAX_LENGTH_STRING (WIDECHAR STRING[])</pre> <p>Parameters:</p> <ul style="list-style-type: none"> • STRING: The input character string. <p>Result: The dimensioned length of STRING.</p> <pre>MaxLen = MAX_LENGTH_STRING(STRING) Len = LENGTH_STRING(STRING)</pre> <pre>IF (MaxLen > Len) { // append character to STRING }</pre>
MID_STRING	<p>This function returns the specified number of characters, starting at the specified location in the source string.</p> <pre>CHAR[] MID_STRING (CHAR STRING, LONG Start, LONG Count) WIDECHAR[] MID_STRING (WIDECHAR STRING, LONG Start, LONG Count)</pre> <p>Parameters:</p> <ul style="list-style-type: none"> • STRING: The input character string. • Start: Starting location in the string. • Count: Number of characters to extract. <p>The result is a character string containing the specified characters.</p> <pre>STRING = 'ABCDEFGHIJK' Substr = MID_STRING(STRING, 5, 4) (* Substr = 'EFGH' *)</pre>
REDIRECT_STRING	<p>This keyword is used to pass all strings from device 1 to device 2 and all strings from device 2 to device 1. This is called a redirection and you can assign up to eight at one time.</p> <pre>REDIRECT_STRING (Number, DEV1, DEV2)</pre> <p>The parameter Number identifies the particular redirection (1-8). To cancel a redirection, pass zero for Device1 and Device2.</p> <p>NOTE: <i>Redirections are lost if system power is turned off.</i></p>
REMOVE_STRING	<p>This function removes characters from the specified string. All characters up to and including the first occurrence of the specified sequence are removed.</p> <pre>CHAR[] REMOVE_STRING (CHAR STRING, CHAR Seq[], LONG Start) WIDECHAR[] REMOVE_STRING (WIDECHAR STRING, WIDECHAR Seq[], LONG Start)</pre> <p>Parameters:</p> <ul style="list-style-type: none"> • STRING: String from which to find and remove characters. • Seq: Sequence of characters to find. • Start: Starting position in the string to begin search. <p>The result is a string containing the removed characters. If the character sequence was not found, an empty string is returned.</p> <pre>STRING = 'ABCDEF' Substr = REMOVE_STRING(STRING, 'BC', 1) (* Substr = 'ABC' *) (* STRING = 'DEF' *)</pre>

STRING Keywords (Cont.)	
RIGHT_STRING	<p>Returns the specified number of characters from the end of a string.</p> <pre>CHAR[] RIGHT_STRING (CHAR STRING[], LONG Count) WIDECHAR[] RIGHT_STRING (WIDECHAR STRING[], LONG Count)</pre> <p>Parameters:</p> <ul style="list-style-type: none"> • STRING: The string from which to extract the characters. • Count: The number of character to copy from the end of the string. <p>The return is a string containing a copy of the last Count characters from STRING.</p> <pre>STRING = 'ABCDEFGH' Substr = RIGHT_STRING(STRING, 3) // Substr = 'EFG'</pre>
SEND_STRING	<p>This keyword sends a string to a NetLinx device/port.</p> <p>The syntax is:</p> <pre>SEND_STRING DEV, '<string>'</pre> <p>- or -</p> <pre>SEND_STRING DEV[], '<string>'</pre> <p>When sending to an IP socket, you may receive the following error (via ONERROR event):</p> <pre>17 Local Port Not Open</pre> <p>This error means you are trying to send a string to a local port on which IP_CLIENT_OPEN (page 98) or IP_SERVER_OPEN (page 99) has not been called.</p>
SET_LENGTH_STRING	<p>This function sets the length of a CHAR or WIDECHAR string. This function is retained for compatibility with previous versions of Axxess. It provides the same functionality as SET_LENGTH_ARRAY (page 32).</p> <pre>SET_LENGTH_STRING (CHAR STRING[], LONG Len) SET_LENGTH_STRING (WIDECHAR STRING[], LONG Len)</pre> <p>Parameters:</p> <ul style="list-style-type: none"> • STRING: The input character string. • Len: The new string length. <pre>SET_LENGTH_STRING(STRING, 10)</pre>
STRING	This keyword defines a section in a DATA event handler for processing SEND_STRING instructions.
STRING_TO_VARIABLE	See page 70.
UPPER_STRING	<p>This function changes all alphabetic characters in the specified string to upper case.</p> <p>The syntax:</p> <pre>CHAR[] UPPER_STRING (CHAR STRING[]) WIDECHAR[] UPPER_STRING (WIDECHAR STRING[])</pre> <p>Parameters:</p> <ul style="list-style-type: none"> • STRING: The character string to convert to upper case. <p>Result: The converted character string.</p> <pre>UCString = UPPER_STRING(STRING)</pre>
VARIABLE_TO_STRING	See page 53.

Structure Keywords

Overview

Structures group different data types together as one data unit. Structures also group arrays of structures together so that each element of the array contains all of the elements of the structure.

NOTE: *Arrays are limited by their inability to have multiple data-types within one array. NetLinx supports Structures to remove this limitation. Refer to the Array Keywords on page 30 for information on Arrays.*

Structures are defined within the DEFINE_TYPE section. The DEFINE_TYPE section appears between the DEFINE_CONSTANT section and the DEFINE_VARIABLE section.

NOTE: *Since structures cannot be used within the DEFINE_CONSTANT section but must be declared before they are used within the DEFINE_VARIABLE section, placing DEFINE_TYPE between DEFINE_CONSTANT and DEFINE_VARIABLE is the logical location.*

The standard format for structures is:

```
STRUCTURE <name>
{
    [<type>] <data1>
    [<type>] <data2>
    .
    .
}
```

Example:

```
DEFINE_TYPE
STRUCTURE NEWSTRUCT
{
    INTEGER Number
    CHAR Text[20]
}
```

In the example above, a structure named NEWSTRUCT is declared to contain two data types, a 16-bit number and a 20-character array. Once declared, a structure may be used in the same way as any other data type. Here is a syntax sample:

```
DEFINE_VARIABLE
NEWSTRUCT MyNewStruct
NEWSTRUCT MyNewStructArray[3]
```

Structures can be initialized using set notation as in the two examples below. Notice that the members of each structure, as well as the entire array, are enclosed in braces:

```
MyNewStruct.Number = 0
MyNewStruct.Text= 'Copyright by Company X'

MyNewStructArray[1].Number = 1
MyNewStructArray[1].Text = 'Line 1'
MyNewStructArray[2].Number = 2
MyNewStructArray[2].Text = 'Line 2'
MyNewStructArray[3].Number = 3
MyNewStructArray[3].Text = 'Line 3'
```

Structure members are referenced using dot-operator syntax as shown below:

```
MyNewStruct.Number = 0
MyNewStructArray[1].Number = 20
SET_LENGTH_STRING (MyNewStruct.Text, 16)
```

Example - Using Structures to Define a Database Table

A database table is an array of structures; the database table is an array of records - each record is a structure. Each record contains data of different types.

Consider the elements of a database table. We then show how to define the structure and create a variable that uses the data structure in an array. We show how to access the individual elements of the structure.

```
Employee Number (* INDEX - Integer Value *)
Employee National Insurance Number (* National Insurance Number - Long *)
Employee First Name (* First Name - Character Array *)
Employee Last Name (* Last Name - Character Array *)
Contribution to Pension (* Contribution in % - Float *)
```

Using the standard format shown above, the 'employee' structure is defined in the DEFINE_TYPE section:

```
DEFINE_TYPE
STRUCTURE EMP
{
    INTEGER EMP_NUM
    CHAR NI_NUM[9]
    CHAR F_NAME[16]
    CHAR L_NAME[16]
    FLOAT CONT_PENSION
}
```

Within the `DEFINE_VARIABLE` section, an instance of the structure and an array of the structure is defined as follows:

```
DEFINE_VARIABLE
EMP JOHN_DOE
EMP AMX_EMP[1000]
```

Within the program, information is assigned to the structure, using the information stored within the structure:

```
JOHN_DOE.EMP_NUM = 101
JOHN_DOE.NI_NUM = '155426367'
JOHN_DOE.F_NAME = 'JOHN'
JOHN_DOE.L_NAME = 'DOE'
JOHN_DOE.CONT_PENSION = 0.01

EMP_INDEX = JOHNDOE.EMP_NUM (* EMP_INDEX = 101 *)
AMX_EMP[101] = JOHNDOE (* AMX_EMP[101] = {101, '155426367', 'JOHN', 'DOE', 0.01}*)
AMX_EMP[60].EMP_NUM = 60
AMX_EMP[60].F_NAME = 'BOB'
```

NOTE: Other uses for arrays of structures include channel listings, speed-dial lists, and user password lists.

Data Sets

NetLinx predefines several structures designed to work with NetLinx device numbers, channels, and levels. Data sets allow you to group and combine certain elements of NetLinx devices. There are three data set structures supported by NetLinx:

- DEV (Device Sets)
- DEVCHAN (Device-Channel Sets)
- DEVLEV (Device-Level Sets)

You have already seen the structure `DEV` structure in the `DEFINE_DEVICE` section. If we were to define the structure `DEV` in the `DEFINE_TYPE` section, it would look like this:

```
STRUCTURE DEV
{
    INTEGER DEVICE
    INTEGER PORT
    INTEGER SYSTEM
}
```

The actual instancing of the structure is unique to the `DEV` structure because you separate the individual structure's elements with colons (:) instead of enclosing the structure with braces {} and separating the elements with commas (,). For example:

```
DEV PANEL_A = 128:1:0      (* correct *)
DEV PANEL_B = {128, 1, 0} (* wrong *)
```

Using the `DEV` structure, you create the structures `DEVCHAN` and `DEVLEV` like this:

```
STRUCTURE DEVCHAN
{
    DEV DEVICE
    INTEGER CHANNEL
}

STRUCTURE DEVLEV
{
    DEV DEVICE
    INTEGER LEVEL
}
```

`DEVCHAN` and `DEVLEV` instance and initialize similarly to other NetLinx structures:

```
DEV PANEL_A = 192:1:0
DEV PANEL_B = 129:1:0
DEVCHAN BUTTON_A = { PANEL_A, 1 }
DEVCHAN BUTTON_B = { 128:1:0, 2 }
DEVLEV LEVEL_1 = { PANEL_A, 1 }
DEVLEV LEVEL_2 = { 128:1:0, 2 }
```

`DEV`, `DEVCHAN`, and `DEVLEV` are structures built into the NetLinx language. You can do more with `DEV`, `DEVCHAN`, and `DEVLEV` than you could with structures you create within the code.

```
DEV PANEL_GROUP1[] = { 128:1:0, 129:1:0, 130:1:0 }
DEV MSP_GROUP[5] = { MSP1, MSP2, MSP3 }
DEVCHAN PRESET1_BUTTONS[5] = { {TP1, 21}, {MSP1, 1}, {134:1:0, 1} }
DEVLEV VOL1_LEVEL[] = { {TP1, 1}, {MSP1, 1}, {192:1:0, 1} }
```

You can use the structures and arrays of the structures within many commands and situations where you would use a device number, a device and channel combination, or a device and level combination. These data sets allow you to combine devices, devices and channels, and devices and levels without using the `DEFINE_COMBINE` or `DEFINE_CONNECT_LEVEL` sections. This gives you the ability to combine certain pages of panels or to combine panels under certain conditions. In Access, once the panels were combined you were locked into that system configuration. Instead of writing the following statements:

```
PUSH[MSP1, 1]
PUSH[MSP2, 1]
PUSH[MSP3, 1]
[RELAY, 1] = ![RELAY, 1]
[MSP1, 1] = [RELAY, 1]
[MSP2, 1] = [RELAY, 1]
[MSP3, 1] = [RELAY, 1]
```

You can use device sets or channel sets to accomplish the same functionality:

```
PUSH[MSP_GROUP,1] (* MSP_GROUP IS A DEV SET *)
  [RELAY, 1] = ![RELAY, 1]
[MSP_GROUP, 1] = [RELAY, 1]
- or -
PUSH[MSP_PRESET1] (* MSP_PRESET1 IS A DEVCHAN SET *)
  [RELAY,1] = ![RELAY, 1]
[MSP_PRESET1] = [RELAY, 1]
```

STRUCTURE Keywords

NetLinx supports the following STRUCTURE keywords:

STRUCTURE Keywords	
DEFINE_TYPE	See page 63.
STRUCT	This is an abbreviated form of the STRUCTURE keyword, and has the same functionality.
STRUCTURE	This keyword introduces the declaration of a STRUCTURE data type. <pre>STRUCTURE <name> { [<type>] <data1> [<type>] <data2> . . }</pre>

Time and Date Keywords

NetLinx supports the following Time & Date keywords:

Time and Date Keywords	
ASTRO_CLOCK	<p>This routine calculates the time of sunset and sunrise at a specified location (longitude and latitude) on a specified date.</p> <pre>SINTEGER ASTRO_CLOCK(DOUBLE Longitude,DOUBLE Latitude,DOUBLE HoursFromGMT,CHAR[] Date,CHAR[] Sunrise,CHAR[] Sunset)</pre> <p>Parameters:</p> <ul style="list-style-type: none"> Longitude: Longitude in Degrees. Fraction of Degrees. West longitudes must be negative. Latitude: Latitude in Degrees. Fraction of Degrees. South latitudes must be negative. HoursFromGMT: Number of hours from GMT. Hours West of GMT can be entered as negative (e.g., -5 for EST, -4 for EDT). Date: In mm/dd/yyyy format. Sunrise: Value gets filled in by the function in 24-hour format. Sunset: Value gets filled in by the function in mm/dd/yyyy format. <p>Result:</p> <ul style="list-style-type: none"> 0: Success -1: Latitude entry error -2: Longitude entry error -3: Hours entry error -4: Date entry error
CLOCK	<p>Sets the date and time on the Master. The date and time settings are propagated over the local bus.</p> <pre>'CLOCK <mm-dd-yy> <hh:mm:ss>'</pre> <p>Example:</p> <pre>SEND_COMMAND 0,"'CLOCK 04-12-05 09:45:31'"</pre>
DATE	<p>The system variable DATE returns the current date in (mm/dd/yy) string format. The wildcard character "?" is not allowed for string comparisons because the actual date is needed.</p> <pre>IF (DATE = '12/25/00')</pre> <pre>{</pre> <pre>}</pre> <p>You can replace the wildcard feature by using the COMPARE_STRING function.</p>
DATE_TO_DAY	<p>This function returns an sinteger representing the day portion of a date string. The S in SINTEGER allows a negative value to be returned.</p> <pre>SINTEGER DATE_TO_DAY (CHAR LDATE[])</pre> <p>Parameters:</p> <ul style="list-style-type: none"> LDATE: [Input] string containing the date in mm/dd/yyyy format. <p>If successful, this function returns an integer (1-31) representing the day portion of the date string. If the specified date is invalid, this function returns -1.</p> <pre>SINTEGER nDaynDay = DATE_TO_DAY ('2/9/1999') // nDay = 9</pre>
DATE_TO_MONTH	<p>This function returns an sinteger representing the month portion of a date string.</p> <pre>SINTEGER DATE_TO_MONTH (CHAR LDATE[])</pre> <p>Parameters:</p> <ul style="list-style-type: none"> LDATE: [Input] string containing the date in mm/dd/yyyy format. <p>If successful, this function returns an integer (1-12) representing the month portion of the date string. If the specified date is invalid, this function returns -1.</p> <pre>SINTEGER nMonthnMonth = DATE_TO_MONTH ('2/9/1999') // nMonth = 2</pre>
DATE_TO_YEAR	<p>This function returns an sinteger representing the year portion of a date string.</p> <pre>SINTEGER DATE_TO_YEAR (CHAR LDATE[])</pre> <p>Parameters:</p> <ul style="list-style-type: none"> LDATE: [Input] string containing the date in mm/dd/yyyy format. <p>If successful, this function returns a 4-digit integer representing the year portion of the date string. If the specified date is invalid, this function returns -1.</p> <pre>SINTEGER nYearnYear = DATE_TO_YEAR ('2/9/1999') // nYear = 1999</pre>
DAY	<p>This system variable returns the current day of the week as one of the following strings: 'MON', 'TUE', 'WED', 'THU', 'FRI', 'SAT' or 'SUN'.</p> <p>Example:</p> <pre>IF (DAY = 'SUN')</pre> <pre>{</pre> <pre>}</pre>
DAY_OF_WEEK	<p>This function returns the day of the week for the specified date.</p> <pre>SINTEGER DAY_OF_WEEK (CHAR LDATE[])</pre> <p>Parameters:</p> <ul style="list-style-type: none"> LDATE: String containing the date in mm/dd/yyyy format. <p>This function returns an SINTEGER representing the day of the week (1 = Sunday, 2 = Monday, etc.).</p> <pre>SINTEGER nDay = DAY_OF_WEEK ('2/13/1999') // nDay = 7 (Saturday)</pre>
LDATE	<p>This system variable returns the current date in (mm/dd/yyyy) string format.</p> <pre>IF (LDATE = '12/25/2000'){}</pre>

Time and Date Keywords (Cont.)	
TIME	<p>This keyword holds the current time as a string in the form "hh:mm:ss". The time is represented in 24-hour format.</p> <pre>IF (TIME = '23:59:59') { }</pre>
TIME_TO_HOUR	<p>This function returns an integer representing the hour portion of a time string.</p> <pre>SINTEGER TIME_TO_HOUR (CHAR TimeStr[]) Parameters: • TimeStr: Input string containing the time in hh:mm:ss format. If successful, this function returns an integer (0-23) representing the hour portion of the time string. The specified time is invalid, this function returns -1. CHAR TimeStr[] = '9:30:08' SINTEGER nHour nHour = TIME_TO_HOUR (TimeStr) // nHour = 9</pre>
TIME_TO_MINUTE	<p>This function returns an integer representing the minute portion of a time string.</p> <pre>SINTEGER TIME_TO_MINUTE (CHAR TimeStr[]) Parameters: • TimeStr: Input string containing the time in hh:mm:ss format. If successful, this function returns an integer (0-59) representing the minute portion of the time string. If the specified time is invalid, this function returns -1. CHAR TimeStr[] = '9:30:08' SINTEGER nMinute nMinute = TIME_TO_MINUTE (TimeStr) // nMinute = 30</pre>
TIME_TO_SECOND	<p>This function returns an integer representing the second portion of a time string.</p> <pre>SINTEGER TIME_TO_SECOND (CHAR TimeStr[]) Parameters: • TimeStr: Input string containing the time in hh:mm:ss format. If successful, this function returns an integer (0-59) representing the second portion of the time string. If the specified time is invalid, this function returns -1. CHAR TimeStr[] = '9:30:08' SINTEGER nSecond nSecond = TIME_TO_SECOND (TimeStr) // nSecond = 8</pre>

Timeline Keywords

Overview

NetLinx timeline functions provide a mechanism for triggering events based upon a sequence of times. The sequence of times is passed into the timeline functions as an array of `LONG` values, with each value representing a time period (in milliseconds) that is either relative to the start time of the timeline or to the previously triggered event.

NOTE: *Timelines introduce the capability to dynamically set up a timed sequence, provide the user with a mechanism to modify the sequence, and allow the user to create, delete, and modify sequences.*

The old way of programming timed sequences was to cascade or nest `WAITs`. Using nested `WAITs` hard-coded the timed sequence; so, the only way to modify the timing was to modify the NetLinx program, recompile, and download. Timelines make adding, deleting and editing the sequence much simpler for the programmer. Timeline functions and debugging allow the timings to be modified without the modify/ compile/ download cycle because the array of times may be modified via NetLinx debugging. Once the timings have been tweaked, the changes can be incorporated in the NetLinx program.

Creating a Timeline

Timelines are represented by the illustration in (FIG. 4). When the `TIMELINE_CREATE` function is executed, the timeline starts at zero and begins counting. When the timer value equals a value in the `TIMES` array, a `TIMELINE_EVENT` is triggered. Within the timeline event, a `TIMELINE` structure is available to get information about the specific time from the `TIMES` array that generated the event. When a relative timeline is created, the NetLinx Master converts the provided relative times into absolute times that are stored internally.

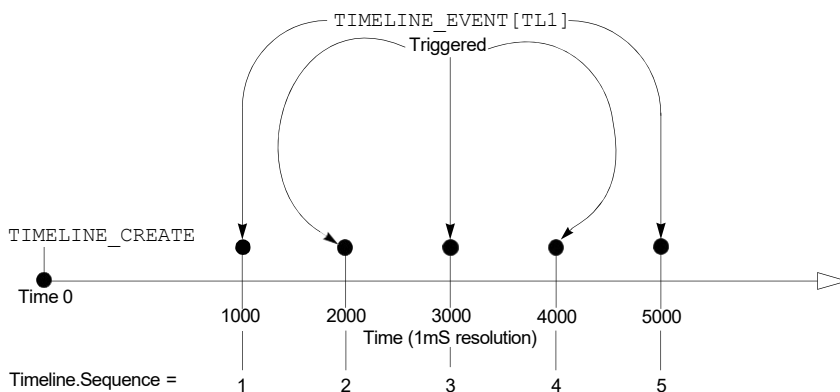

FIG. 4 Timeline representation

The `TIMELINE` structure contains the following members:

```
STRUCTURE TIMELINE
{
    INTEGER    ID           //user supplied ID
    INTEGER    SEQUENCE     //index in Times array
    LONG       TIME         //time since start of timeline
    INTEGER    RELATIVE     //0=absolute 1=relative
    LONG       REPETITION   //# of loops for repeating timeline
}

```

Each `TIMELINE` data member is defined as follows:

- **ID:** The ID that the user assigned to the timeline in the `TIMELINE_CREATE` function.
- **SEQUENCE:** The index of the time in the Times array that was passed to the `TIMELINE_CREATE` function. The `SEQUENCE` data member is used to determine what action to take for the event and is normally decoded with a `SWITCH/CASE` structure (as shown in the example).
- **TIME:** The amount of time that has elapsed since the timeline started. For repeating timelines, the `TIME` and `REPETITION` data members can be used to calculate the total amount of time it has been running.
- **RELATIVE:** If the timeline is operating in relative mode, this data member is equal to `TIMELINE_RELATIVE`. If the timeline is absolute, it is equal to `TIMELINE_ABSOLUTE`.
- **REPETITION:** If the timeline was created with `TIMELINE_REPEAT`, this data member holds the number of times the timeline has been executed. `REPETITION` contains zero for the first pass through the timeline. Thus, the calculation to determine the total amount of time the timeline has been running is simply:

`TIMELINE.TIME * TIMELINE.REPETITION.`

Return Values:

0	Successful
1	Timeline ID already in use
2	Specified array is not an array of LONGs
3	Specified length is greater than the length of the passed array
4	Out of memory

Example:

```

DEFINE_VARIABLE
LONG TimeArray[100]

DEFINE_CONSTANT
TL1 = 1
TL2 = 2

DEFINE_EVENT
TIMELINE_EVENT[TL1] // capture all events for Timeline 1
{
    switch(Timeline.Sequence) // which time was it?
    {
        case 1: { SEND_COMMAND dvPanel,"'TEXT1-1 1'" }
        case 2: { SEND_COMMAND dvPanel,"'TEXT1-1 2'" }
        case 3: { SEND_COMMAND dvPanel,"'TEXT1-1 3'" }
        case 4: { SEND_COMMAND dvPanel,"'TEXT1-1 4'" }
        case 5: { SEND_COMMAND dvPanel,"'TEXT1-1 5'" }
    }
}

TIMELINE_EVENT[TL2]
{
    switch(Timeline.Sequence)
    {
        case 1: { SEND_COMMAND dvPanel,"'TEXT2-2 1'" }
        case 2: { SEND_COMMAND dvPanel,"'TEXT2-2 2'" }
        case 3: { SEND_COMMAND dvPanel,"'TEXT2-2 3'" }
        case 4: { SEND_COMMAND dvPanel,"'TEXT2-2 4'" }
        case 5: { SEND_COMMAND dvPanel,"'TEXT2-2 5'" }
    }
}

DEFINE_PROGRAM

PUSH[dvPanel,1]
{
    TimeArray[1] = 1000
    TimeArray[2] = 2000
    TimeArray[3] = 3000
    TimeArray[4] = 4000
    TimeArray[5] = 5000
    TIMELINE_CREATE(TL1, TimeArray, 5, TIMELINE_ABSOLUTE, TIMELINE_REPEAT)
}

PUSH[dvPanel,2]
{
    TimeArray[1] = 1000
    TimeArray[2] = 1000
    TimeArray[3] = 1000
    TimeArray[4] = 1000
    TimeArray[5] = 1000
    TIMELINE_CREATE(TL2, TimeArray, 5, TIMELINE_RELATIVE, TIMELINE_ONCE)
}

```

The example above creates two timelines (TL1 and TL2) that trigger events at the same rate (once per second).

- TL1 uses `TIMELINE_ABSOLUTE` to specify that the times in `TimeArray` are absolute with respect to the start of the timeline. Since TL1 specifies the `TIMELINE_REPEAT`, it is also repeating and will generate a `TIMELINE_EVENT` every second iterating through all five times in a round-robin fashion: 1,2,3,4,5,1,2,3,4,5,1,2,3, and so on.
- TL2 uses `TIMELINE_RELATIVE` to specify that the times in `TimeArray` are relative to each other (i.e. each events occurs 1000 milliseconds after the previous). Since TL2 specifies the `TIMELINE_ONCE` parameter, it will execute the entire timeline once, then stop: 1,2,3,4,5.

TIMELINE Example

The following code is an example of how to use `TIMELINE` functions.

```

PROGRAM_NAME='TimelineExample'
(*{{PS_SOURCE_INFO(PROGRAM STATS)                                     *)

(*****
(* FILE_CREATED_ON: 05/22/2001 AT: 12:05:56                         *)
(*****
(* FILE_LAST_MODIFIED_ON: 05/22/2001 AT: 12:15:56                  *)
(*****
(* ORPHAN_FILE_PLATFORM: 1                                         *)
(*****

```

```

(!!FILE REVISION: *)
(* REVISION DATE: 05/22/2001 *)
(*)

(* COMMENTS: *)
(*)
(*****
*)}PS_SOURCE_INFO *)
(*****

(*****
(*) DEVICE NUMBER DEFINITIONS GO BELOW *)
(*****

DEFINE_DEVICE
dvPanel = 128:1:0
dvDebug = 0:0:0

(*****
(*) CONSTANT DEFINITIONS GO BELOW *)
(*****
DEFINE_CONSTANT
MY_LINE_1 = 1
MY_LINE_2 = 2

(*****
(*) VARIABLE DEFINITIONS GO BELOW *)
(*****
DEFINE_VARIABLE
LONG TimeArray[100]
INTEGER iLoop

(*****
(*) STARTUP CODE GOES BELOW *)
(*****
DEFINE_START

(*****
(*) THE EVENTS GOES BELOW *)
(*****
DEFINE_EVENT
TIMELINE_EVENT[MY_LINE_1]
{
switch(Timeline.Sequence)
{
case 1: { SEND_COMMAND dvPanel,"TEXT1-1 1" }
case 2: { SEND_COMMAND dvPanel,"TEXT1-1 2" }
case 3: { SEND_COMMAND dvPanel,"TEXT1-1 3" }
case 4: { SEND_COMMAND dvPanel,"TEXT1-1 4" }
case 5: { SEND_COMMAND dvPanel,"TEXT1-1 5" }
}
SEND_STRING dvDebug,"Timer ',ITOA(Timeline.ID),' Event ',ITOA(Timeline.Sequence),
' Time= ',ITOA(Timeline.Time),
'Repetition = ',ITOA(Timeline.Repetition),' Relative = ',ITOA(Timeline.Relative)"
}
TIMELINE_EVENT[MY_LINE_2]
{
switch(Timeline.Sequence)
{
case 1: { SEND_COMMAND dvPanel,"TEXT2-2 1" }
case 2: { SEND_COMMAND dvPanel,"TEXT2-2 2" }
case 3: { SEND_COMMAND dvPanel,"TEXT2-2 3" }
case 4: { SEND_COMMAND dvPanel,"TEXT2-2 4" }
case 5: { SEND_COMMAND dvPanel,"TEXT2-2 5" }
}
SEND_STRING dvDebug,"Timer ',ITOA(Timeline.ID),' Event ',ITOA(Timeline.Sequence),
' Time= ',ITOA(Timeline.Time),' Repetition = ',ITOA(Timeline.Repetition),
' Relative = ',ITOA(Timeline.Relative)"
}
}

(*****
(*) THE ACTUAL PROGRAM GOES BELOW *)
(*****

DEFINE_PROGRAM

```

```

(*****)
(* create will sort the order of the times but index stays *)
(* with the time. This example will execute 1 2 4 3 5 *)
(* sequence numbers *)
(*****)

PUSH[dvPanel,1]
{
TimeArray[1] = 1000
TimeArray[2] = 2000
TimeArray[4] = 3000
TimeArray[3] = 4000
TimeArray[5] = 5000
TIMELINE_CREATE(MY_LINE_1,TimeArray,5,TIMELINE_ABSOLUTE,TIMELINE_ONCE)
}

PUSH[dvPanel,2]
{
TimeArray[1] = 1000
TimeArray[2] = 2000
TimeArray[3] = 3000
TimeArray[4] = 4000
TimeArray[5] = 5000
TIMELINE_CREATE(MY_LINE_2,TimeArray,5,TIMELINE_ABSOLUTE,TIMELINE_REPEAT)
}

(*****)
(* Modify the timeline my kill, pause and restarting *)
(*****)
PUSH[dvPanel,3]
{
IF(TIMELINE_ACTIVE(MY_LINE_1))TIMELINE_KILL(MY_LINE_1)
IF(TIMELINE_ACTIVE(MY_LINE_2))TIMELINE_KILL(MY_LINE_2)
}
PUSH[dvPanel,4]
{
IF(TIMELINE_ACTIVE(MY_LINE_1))TIMELINE_PAUSE(MY_LINE_1)
IF(TIMELINE_ACTIVE(MY_LINE_2))TIMELINE_PAUSE(MY_LINE_2)
}
PUSH[dvPanel,5]
{
IF(TIMELINE_ACTIVE(MY_LINE_1))TIMELINE_RESTART(MY_LINE_1)
IF(TIMELINE_ACTIVE(MY_LINE_2))TIMELINE_RESTART(MY_LINE_2)
}

(*****)
(* Force time to a different value *)
(*****)
PUSH[dvPanel,6]
{
IF(TIMELINE_ACTIVE(MY_LINE_1))
TIMELINE_SET(MY_LINE_1,2000)
}
(*****)
(* Get the current time from create *)
(*****)

PUSH[dvPanel,7]
{
SEND_COMMAND dvPanel,"TEXT3-', 'Timer 1 Time is ',ITOA(TIMELINE_GET(MY_LINE_1))"
SEND_COMMAND dvPanel,"TEXT4-', 'Timer 2 Time is ',ITOA(TIMELINE_GET(MY_LINE_2))"
}

(*****)
(* Pause and restart the timeline at new locations *)
(*****)
PUSH[dvPanel,8]
{
TIMELINE_PAUSE(MY_LINE_1)
TIMELINE_PAUSE(MY_LINE_2)
TIMELINE_SET(MY_LINE_1,0)
TIMELINE_SET(MY_LINE_2,0)
TIMELINE_RESTART(MY_LINE_1)
TIMELINE_RESTART(MY_LINE_2)
}

```

```
(*****
(*)          END OF PROGRAM          *)
(*)      DO NOT PUT ANY CODE BELOW THIS COMMENT      *)
(*****)
```

TIMELINE IDS

When creating a `TIMELINE_EVENT`, the timeline ID must be a user defined long constant. The compiler will not semantic check the type of the timeline ID, and the NetLinx runtime system will attempt to cast the contents of the timeline ID constant, to a long constant. A runtime error will occur if the cast is unsuccessful.

Here's an example of `TIMELINE` code:

```
DEFINE_VARIABLE
CONSTANT LONG TimelineID_1 = 1
CONSTANT LONG TimelineID_2 = 2
CONSTANT LONG TimelineID_3 = 3
CONSTANT LONG TimelineID_4 = 4
LONG TimeArray[4] =
{
    1000, // 1 second
    2000, // 2 seconds
    3000, // 3 seconds
    4000 // 4 seconds
}
DEFINE_START
TIMELINE_CREATE (TimelineID_1,TimeArray,LENGTH_ARRAY(TimeArray),TIMELINE_RELATIVE,TIMELINE_REPEAT)
TIMELINE_CREATE (TimelineID_2,TimeArray,LENGTH_ARRAY(TimeArray),TIMELINE_RELATIVE,TIMELINE_REPEAT)
TIMELINE_CREATE (TimelineID_3,TimeArray,LENGTH_ARRAY(TimeArray),TIMELINE_RELATIVE,TIMELINE_REPEAT)
TIMELINE_CREATE (TimelineID_4,TimeArray,LENGTH_ARRAY(TimeArray),TIMELINE_RELATIVE,TIMELINE_REPEAT)

DEFINE_EVENT
// typical TIMELINE_EVENT statement
TIMELINE_EVENT[TimelineID_1] // capture all events for Timeline 1
{
    SEND_STRING 0,"TL ID = ', itoa(timeline.id)', sequence = ',itoa(timeline.sequence)"
}
// example of "stacked" TIMELINE_EVENT statements
TIMELINE_EVENT[TimelineID_2] // capture all events for Timeline 2
TIMELINE_EVENT[TimelineID_3] // capture all events for Timeline 3
TIMELINE_EVENT[TimelineID_4] // capture all events for Timeline 4
{
    SEND_STRING 0,"TL ID = ', itoa(timeline.id)', sequence = ',itoa(timeline.sequence)"
}
// end
```

NetLinx supports the following `TIMELINE` keywords:

TIMELINE Keywords	
TIMELINE_ACTIVE	<p>This function is used to determine if a timeline has been created. If the timeline does not exist (i.e. <code>TIMELINE_CREATE</code> has not been called) this function returns zero.</p> <pre>INTEGER TIMELINE_ACTIVE (LONG Id)</pre> <p>Parameters:</p> <ul style="list-style-type: none"> Id: A user defined value that uniquely identifies this timeline. Each timeline must be assigned a unique identifier starting with number one. <p>Returns:</p> <ul style="list-style-type: none"> 0: Not created. Non-zero: The timeline has been created. <pre>IF (TIMELINE_ACTIVE (TL1)) // if timeline 1 is running { // do something }</pre>
TIMELINE_CREATE	<p>Creates an initial timeline and specifies the attributes of the timeline. Time is measured in millisecond (1/1000 of a second) increments.</p> <pre>INTEGER TIMELINE_CREATE (LONG Id, LONG Times[], LONG Length, LONG Relative, LONG Repeat)</pre> <p>Parameters:</p> <ul style="list-style-type: none"> Id: A user defined value that uniquely identifies this timeline. Each timeline must be assigned a unique identifier starting with number one. Times: An array of times where each time specifies when a <code>TIMELINE_EVENT</code> will be triggered. The times in the array may be relative to each other or relative to the start of the timeline depending upon the <code>Relative</code> parameter. For an absolute timeline, it is not necessary for the times in the array to be sorted in any particular order (the NetLinx master does this internally for you). The NetLinx master makes an internal copy of the values in the array allowing the user to modify the passed in array as desired without affecting the operation of the timeline. Length: The count of times in the <code>Times</code> array. Relative: Indicates whether the <code>Times</code> array contains relative times or absolute times. Relative indicates the each time given is relative to the last event time (i.e. the time delay in between the triggered events). Absolute indicates that each time given is absolute with respect to the start of the timeline. Repeat: Indicates whether the timeline should automatically start over again when <code>Length</code> events have been triggered.

TIMELINE Keywords (Cont.)

TIMELINE_EVENT	<p>These events are generated when a timeline's internal timer is equal to one of the specified times in the times array. The <code>TIMELINE_EVENT</code> must be placed in the <code>DEFINE_EVENT</code> section of the program.</p> <pre>TIMELINE_EVENT[timelineID]</pre> <p>See the <code>TIMELINE_CREATE</code> function (above) for a more detailed description.</p>
TIMELINE_GET	<p>This function returns the value of the specified timeline's timer. The timer indicates the number of milliseconds that have passed since the timeline started. If the timeline is paused the timer is also paused and subsequent calls to <code>TIMELINE_GET</code> will return the same value.</p> <pre>LONG TIMELINE_GET (LONG Id)</pre> <p>Parameters:</p> <ul style="list-style-type: none"> • <code>Id</code>: A user defined value that uniquely identifies this timeline. Each timeline must be assigned a unique identifier starting with number one. <p>Result: This function returns the specified timeline's internal timer. The timer value represents the number of milliseconds that have passed since the timeline started.</p> <pre>TIMELINE_SET (TL1, TIMELINE_GET (TL1)+1000) // jump ahead 1 second</pre>
TIMELINE_KILL	<p>This function is used to terminate a timeline. Any further references to the specified timeline ID are invalid.</p> <pre>INTEGER TIMELINE_KILL (LONG Id)</pre> <p>Parameters:</p> <ul style="list-style-type: none"> • <code>Id</code>: A user defined value that uniquely identifies this timeline. Each timeline must be assigned a unique identifier starting with number one. <p>Result:</p> <ul style="list-style-type: none"> • 0: Successful • 1: Specified timeline ID invalid <pre>TIMELINE_KILL(TL1) // permanently destroy the timeline</pre>
TIMELINE_PAUSE	<p>This function is used to suspend the execution of a timeline. It may be restarted from where it left off with the <code>TIMELINE_RESTART</code> function.</p> <pre>INTEGER TIMELINE_PAUSE (LONG Id)</pre> <p>Parameters:</p> <ul style="list-style-type: none"> • <code>Id</code>: A user defined value that uniquely identifies this timeline. Each timeline must be assigned a unique identifier starting with number one. <p>Result:</p> <ul style="list-style-type: none"> • 0: Successful • 1: Specified timeline ID invalid <pre>TIMELINE_PAUSE(TL1) // momentarily suspend the timeline</pre>
TIMELINE_RELOAD	<p>This function is used to change the array times of a timeline. The new array of times takes affect immediately even if the timeline is currently executing. If the timeline is executing when this function is called the timeline continues to execute and the next matching time from the new array triggers an event.</p> <pre>INTEGER TIMELINE_RELOAD (LONG Id, LONG Times[], LONG Length)</pre> <p>Parameters:</p> <ul style="list-style-type: none"> • <code>Id</code>: A user defined value that uniquely identifies this timeline. Each timeline must be assigned a unique identifier starting with number one. • <code>Times</code>: An array of times where each time specifies when a <code>TIMELINE_EVENT</code> will be triggered. The times in the array must utilize the same time base (<code>TIMELINE_RELATIVE</code> or <code>TIMELINE_ABSOLUTE</code>) as determined by the original call to <code>TIMELINE_CREATE</code>. The NetLinx master makes an internal copy of the values in the array allowing the user to modify the passed in array as desired without affecting the operation of the timeline. • <code>Length</code>: The count of times in the <code>Times</code> array. <p>Result:</p> <ul style="list-style-type: none"> 0: Successful 1: Timeline ID already in use 2: Specified array is not an array of LONGs. 3: Specified length is greater than the length of the passed array. 4: Out of memory <pre>TimeArray[1] = 1000 TimeArray[2] = 1500 TimeArray[3] = 2000 TIMELINE_RELOAD(TL1, TimeArray, 3) // Modify the timeline</pre>
TIMELINE_RESTART	<p>This function is used to continue execution of a timeline that was suspended with <code>TIMELINE_PAUSE</code>.</p> <pre>INTEGER TIMELINE_RESTART (LONG Id)</pre> <p>Parameters:</p> <ul style="list-style-type: none"> • <code>Id</code>: A user defined value that uniquely identifies this timeline. Each timeline must be assigned a unique identifier starting with number one. <p>Result:</p> <ul style="list-style-type: none"> 0: Successful 1: Specified timeline ID invalid <pre>TIMELINE_RESTART(TL1) // continue the timeline</pre>

TIMELINE Keywords (Cont.)

TIMELINE_SET	<p>This function is used to modify the current timer value of a timeline. The timeline's timer is immediately set to the new value regardless of whether the timeline is executing or not.</p> <pre>INTEGER TIMELINE_SET (LONG Id, LONG Timer)</pre> <p>Parameters:</p> <ul style="list-style-type: none">• Id: A user defined value that uniquely identifies this timeline. Each timeline must be assigned a unique identifier starting with number one.• Timer: The new value for the timeline's internal timer. <p>Result:</p> <ul style="list-style-type: none">0: Successful1: Specified timeline ID invalid2: Specified timer value out of range <pre>TIMELINE_SET (TL1,0) // start it over again</pre>
---------------------	--

Unicode Keywords

Overview

NetLinx Unicode Functions allow programmers to embed Unicode String literals in their NetLinx programs, manipulate them using run-time functions and send them to touch panels and other user interfaces.

Working With Unicode in NetLinx Studio

NetLinx supports 16-bit Unicode characters. You can type Unicode character literals strings into you program, assigned them to variables, manipulate them using string operations, read and write Unicode characters to the file system and send Unicode strings to user interfaces for display.

Configuring NetLinx Studio

Before you begin to work with Unicode, you must enable the UTF-8 Unicode option and the Unicode Compile option in NetLinx Studio. The UTF-8 Unicode option will tell Studio to store your file as UTF-8, which will support Unicode characters. The Unicode Compile option will tell Studio to process the `_wc` pre-processor statements to properly handle Unicode embedded in your source files at compile time.

Enabling UTF-8 in NetLinx Studio

1. Choose **Settings-> Preferences** from the menu bar.
2. Select the **Editor - Display and Indentations** (FIG. 5).

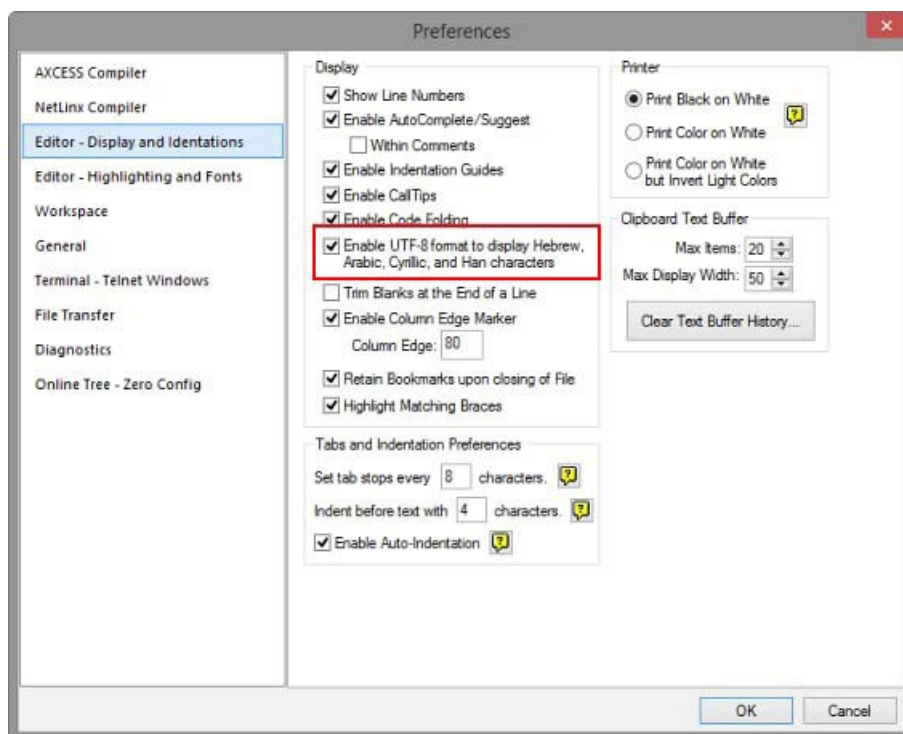

FIG. 5 NetLinx Studio - Preferences dialog (Editor - Display and Indentations options)

3. Under *Display*, check the **Enable UTF-8 format to display Hebrew, Arabic, Cyrillic and Han characters** checkbox.
4. Click **OK** to save changes and close the Preferences dialog.

Enabling Unicode Compiling in NetLinx Studio

1. Choose **Settings > Preferences** from the menu bar
2. Select the **NetLinx Compiler** tab (FIG. 6).

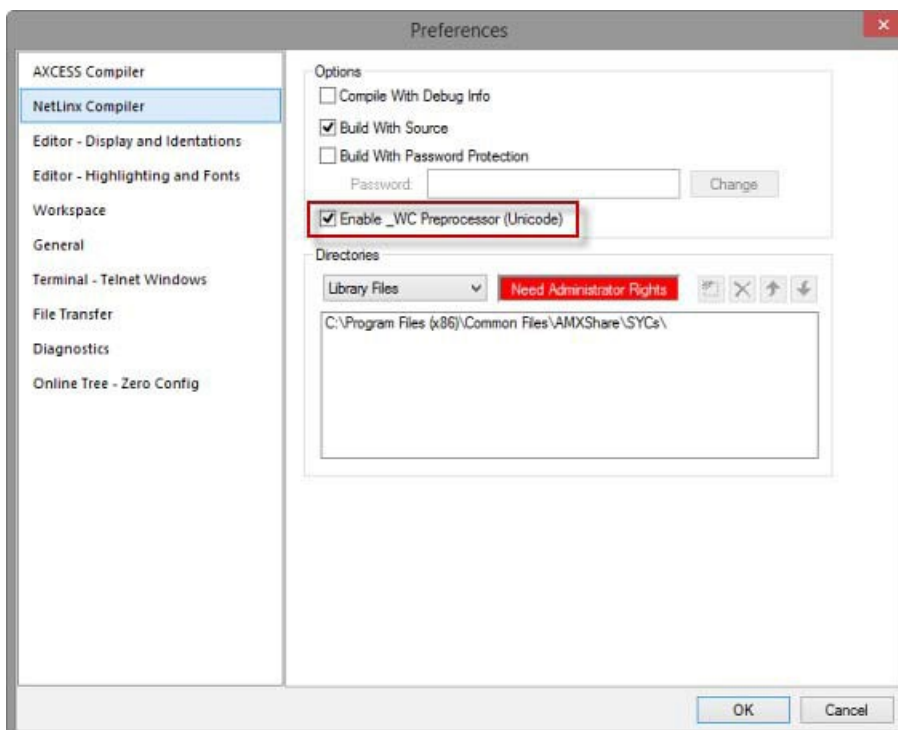

FIG. 6 NetLinX Studio - Preferences dialog (NetLinX Compiler options)

3. Under *Options*, check the **Enable _WC Preprocessor** checkbox.
4. Click **OK** to save changes and close the Preferences dialog.

Including the Unicode Library

The Unicode Library is implemented in a NetLinX Include file, **UnicodeLib.axi**, that must be included in your program in order to access the Unicode functions.

The Unicode Library is located in an Include file located in the **C:\Program Files\Common Files\AMXShare\AXIs** directory. Because this location is the default Include search path, you do not need to specify the directory in the include statement.

To include the Unicode Library to your program add these lines to your program:

```
(*****  
(*          INCLUDE FILES GO BELOW          *)  
(*****  
#INCLUDE 'UnicodeLib.axi'
```

Defining a Unicode String Literal

To enter Unicode characters into your program, enclose the characters in single quotes, like you would any other string, and wrap the string literal in the Unicode macro `_WC`. Here is an example:

```
_WC('Your string goes here')
```

- All Unicode string literals must be wrapped in the `_WC` macro.
- Failing to wrap a Unicode string in the `_WC` macro will result in a compiler error.

Storing a Unicode String

Unicode strings are stored in `WIDECHAR` arrays, similar to the way ASCII strings are stored in `CHAR` arrays. To define a `WIDECHAR` constant or variable and initialize it using a Unicode string literal, use the following syntax:

```
WIDECHAR wcMyString[] = _WC('My String')
```

NOTE: The *"wc"* prefix is Hungarian notation for widechar. This is simply a programming convention and is completely optional. Hungarian notation helps you better identify your variables while you are programming and is a general recommended standard. For more information, see [Wikipedia's Hungarian Notation page](#).

Working with WIDECHAR Arrays and Unicode Strings

Working with `WIDECHAR` arrays and Unicode strings is very similar to working with `CHAR` arrays and ASCII strings. Most operation that can be performed on a `CHAR` array can be performed on a `WIDECHAR` array.

For instance, to assign a string to a variable use this syntax:

```
wcMyString = _WC('My String')
```

The string functions defined for `CHAR` arrays have been defined for `WIDECHAR` array for use in Unicode programming. These functions allow you to operate on strings similar to the way you would with `CHAR` array. For instance, to remove the first 3 characters from a `WIDECHAR` array and return those characters as a `WIDECHAR` array, use `WC_GET_BUFFER_STRING`:

```
wcRemoved = WC_GET_BUFFER_STRING(wcMyString,3)
```

You will find that most other function work exactly as their `CHAR` counterpart do except they work on and return `WIDECHAR` arrays. The list of Unicode compatible functions is:

- `WC_COMPARE_STRING`
- `WC_GET_BUFFER_CHAR`
- `WC_GET_BUFFER_STRING`
- `WC_LEFT_STRING`
- `WC_FIND_STRING`
- `WC_LENGTH_STRING`
- `WC_LOWER_STRING`
- `WC_MAX_LENGTH_STRING`
- `WC_MID_STRING`
- `WC_REMOVE_STRING`
- `WC_RIGHT_STRING`
- `WC_SET_LENGTH_STRING`
- `WC_UPPER_STRING`

Character Case Mappings

Converting between upper and lower case is accomplished by using the Unicode.org character database to determine the mapping between upper case and lower case characters. Not all Unicode characters have an upper or lower case equivalent; these characters will not be affected by `WC_UPPER_STRING` and `WC_LOWER_STRING`. Only the characters defined by Unicode.org as having an upper or lower case mapping are affected by these functions.

For more information on Unicode character conversion, see the Unicode.org character conversion FAQ.

Concatenating String

Unicode strings and `WIDECHAR` array cannot be concatenated using the same syntax that ASCII strings use. In NetLinx, string expressions are enclosed in double quotes and can only contain 8-bit strings. To concatenate Unicode strings and `WIDECHAR` arrays, you must use the `WC_CONCAT_STRING` function:

```
wcMyString = WC_CONCAT_STRING(_WC('First name'),_WC(' Surname'))
```

If you attempt to concatenate Unicode strings or `WIDECHAR` arrays using NetLinx string expressions, expect data loss.

Converting Between WIDECHAR and CHAR

On occasion, you may need to convert a `CHAR` array to a `WIDECHAR` array or a `WIDECHAR` array to a `CHAR` array. The `CH_TO_WC` and `WC_TO_CH` functions can be used to accomplish these conversions. For example:

```
wcMyString = CH_TO_WC('Any ASCII string')
wcMyString = CH_TO_WC(cMyString)
```

```
cMyString = WC_TO_CH(_WC('Any Unicode string'))
cMyString = WC_TO_CH(wcMyString)
```

- When converting from `WIDECHAR` to `CHAR`, Unicode characters are converted to '?'.
- Any ASCII or extended ASCII characters, i.e. 8-bit characters, contained in the `WIDECHAR` array will appear in the `CHAR` array.
- Converting from `CHAR` to `WIDECHAR` never results in loss of data.

Using FORMAT

The NetLinx Unicode library does not include a Unicode compatible `FORMAT` function. In NetLinx, the `FORMAT` function is used to convert numbers to text. To use `FORMAT` with Unicode string, use `FORMAT` to convert the number to a `CHAR` array and then use `CH_TO_WC` and `WC_CONCAT_STRING` to combine the result with an existing `WIDECHAR` array.

The following two syntaxes are functionality equivalent:

```
fTemperature = 98.652
cMyString = FORMAT('The current temperature is %3.2f',fTemperature)
```

```
fTemperature = 98.652
cTempString = FORMAT('%3.2f',fTemperature)
wcMyString = _WC('The current temperature is ')
wcMyString = WC_CONCAT_STRING(wcMyString,CH_TO_WC(cTempString))
```

Reading and Writing to Files

The NetLinx Unicode library supports reading and writing of `WIDECHAR` arrays. The `WC_FILE` routines operate the same as the `FILE` routines with the exception of `FILE_OPEN`. `WC_FILE_OPEN` takes an additional parameter; the file format. The `WC_FILE_OPEN` returns a special file handle so it is important to only use the file handle returned by `WC_FILE_OPEN` with other `WC_FILE` functions and the file handle used with `WC_FILE` functions must have been obtained by calling `WC_FILE_OPEN`.

The NetLinx Unicode library supports three different file formats for compatibility with files created on a computer. Windows Notepad supports the same three file formats so files created in Notepad can be read using the `WC_FILE` routines and files created using the `WC_FILE` routines can be read with Notepad.

When reading or appending to file, the file format is automatically determined when the file is opened. You can pass in a variable to `WC_FILE_OPEN` and the function will set the variable to the file format that was detected. When writing files, the file format parameter will determine how data is written to the file. The following constants can be used for specifying or checking the file format: `WC_FORMAT_UNICODE`, `WC_FORMAT_UNICODE_BE`, `WC_FORMAT_UTF8`.

The Unicode file format, specified by the constant `WC_FORMAT_UNICODE`, is the fastest to encode and decode. You should use this format unless you have a particular application that requires either UTF-8 or Unicode BE encoding.

The `WC_FILE_READ/WRITE` functions take the number of characters that will be read or written to the file. However, the functions return the number of bytes read or written to the file, not the number of characters. For Unicode and Unicode BE encoding, there are 2 bytes for every character.

For UTF-8 encoding, the number of bytes for every character varies depending on the character.

Unicode filenames are not supported. The parameter for the file name is a `CHAR` array. Always use a non-Unicode name for the file.

The following file functions support `WIDECHAR` arrays:

- `WC_FILE_OPEN`
- `WC_FILE_CLOSE`
- `WC_FILE_READ`
- `WC_FILE_READ_LINE`
- `WC_FILE_WRITE`
- `WC_FILE_WRITE_LINE`

Send Strings to a User Interface

Sending a `WIDECHAR` array to a user interface is accomplished using `WC_TP_ENCODE`. `WC_TP_ENCODE` takes a `WIDECHAR` array and returns a `CHAR` array formatted for a user interface `UNI` or `BAU` command.

```
cMyString = WC_TP_ENCODE(wcMyString)
SEND_COMMAND dvTP, ""^UNI-1,0,',cMyString "
```

Right-to-Left Unicode Strings

Right-to-Left Unicode languages are stored in memory the same way left-to-right language are. The first memory position of an array contains the first logical character.

You can access the right-most character of a Right-to-Left Unicode string using this notation:

```
wchChar = wcString[1]
```

Right-to-left languages are not stored differently than left-to-right languages, they are simply rendered differently than right to left languages. However, note that the functions `WC_LEFT_STRING` and `WC_RIGHT_STRING` remove a number of characters from the start and end of a string respectively.

Using `WC_LEFT_STRING` on a right-to-left language will return the number of right-most, i.e. first, characters you requested, not the left-most, i.e. end, characters.

`WC_LEFT_STRING` returns the number of characters request from the front of the string and `WC_RIGHT_STRING` return the number of characters requested from the end of the string, regardless of the language's orientation.

Compiler Errors

The most common type of compiler errors you will encounter while programming for Unicode are caused by not wrapping Unicode string literals in `_WC`, passing a `WIDECHAR` to a function that take a `CHAR` array or passing a `CHAR` array to a function that takes a `WIDECHAR` array.

If you forget to wrap a Unicode string in `_WC`, expect to see the following compiler error:

On the line where the string is defined:

```
C10571: Converting type [string] to [WIDECHAR]
```

On the line where the constant or variable is used:

```
C10585: Dimension mismatch: [1] vs. [0] and C10533: Illegal assignment statement
```

If you try to pass a `CHAR` array to a function that expects a `WIDECHAR` array, expect to see the following compiler error:

On the line where the function call is made

```
C10585: Dimension mismatch: [1] vs. [0] and Type mismatch in call for parameter [WCDATA]
```

If you try to pass a `WIDECHAR` array to a function that expects a `CHAR` array, expect to see the following compiler error:

On the line where the function call is made

```
C10585: Dimension mismatch: [1] vs. [0] and Type mismatch in call for parameter [A]
```

NOTE: *Parameter names might not match those listed above.*

Unicode Keywords

The NetLinx programming language supports the following Unicode keywords:

Unicode Keywords	
_WC	<p>This keyword is a macro for Unicode strings. All Unicode string literals must be contained in single quotes and in the <code>_WC</code> macro.</p> <pre>WIDECHAR wcData[] = WC('Unicode String')</pre>
WC_COMPARE_STRING	<p>This keyword compares two Unicode strings. If either string contains a '?' character, the matching character in the other string is not compared. The '?' is equivalent to a wildcard. For example:</p> <pre>INTEGER WC_COMPARE_STRING(WIDECHAR STR1[], WIDECHAR STR2[])</pre> <p>Parameters:</p> <ul style="list-style-type: none"> <code>STR1</code> - the first widechar string to be compared. <code>STR2</code> - the first widechar string to be compared. <p>Result:</p> <p>The returned result can only be True (1) or False (0).</p> <ul style="list-style-type: none"> 0 = the strings don't match 1 = the strings are the same <p>See <code>COMPARE_STRING</code> (page 127) for a code example.</p>
WC_CONCAT_STRING	<p>This keyword concatenates two <code>WIDECHAR</code> arrays.</p> <pre>WIDECHAR[] WD_CONCAT_STRING(WIDECHAR STR1[], WIDECHAR STR2[])</pre> <p>Parameters:</p> <ul style="list-style-type: none"> <code>STR1</code> - the first widechar string to be concatenated. <code>STR2</code> - the first widechar string to be concatenated. <p>Result:</p> <p>A widechar string which concatenates <code>STR1</code> and <code>STR2</code></p> <pre>wcMyString = WC_CONCAT_STRING(wcString1,wcString2)</pre>
WC_DECODE	<p>This function decodes Unicode string from a character string using one of 4 formats.</p> <pre>WIDECHAR[] WC_DECODE(CHAR cData[], INTEGER Format, LONG Start)</pre> <p>Parameters:</p> <ul style="list-style-type: none"> <code>cData</code>: String containing the encoded Unicode string <code>Format</code>: <ul style="list-style-type: none"> 1 Unicode: The data is encoded as a Unicode formatted stream. The constant <code>WC_FORMAT_UNICODE</code> is defined as a value of 1 for specifying this format. 2 Unicode BE: The data is encoded as a Unicode BE (Big Endian) formatted stream. The constant <code>WC_FORMAT_UNICODE_BE</code> is defined as a value of 2 for specifying this format. 3 UTF-8: The data is encoded as a UTF-8 formatted stream. The constant <code>WC_FORMAT_UTF8</code> is defined as a value of 3 for specifying this format. 4 TP: The data is encoded for use with the UNI TP command. The constant <code>WC_FORMAT_TP</code> is defined as a value of 4 for specifying this format. <code>Stat</code>: Position in Data from which to start reading <p>Result:</p> <p>A <code>WIDECHAR</code> array containing the Unicode data.</p> <pre>wcMyString = WC_DECODE(cData, WC_FORMAT_UNICODE,1)</pre>
WC_ENCODE	<p>This function encodes a Unicode string to a character string using one of 4 formats.</p> <pre>WIDECHAR[] WC_ENCODE(WIDECHAR STRING[], INTEGER Format, LONG Start)</pre> <p>Parameters:</p> <ul style="list-style-type: none"> <code>STRING</code>: String containing the Unicode string to encode <code>Format</code>: <ul style="list-style-type: none"> 1 Unicode: Encode the data as a Unicode formatted stream. The constant <code>WC_FORMAT_UNICODE</code> is defined as a value of 1 for specifying this format. 2 Unicode BE: Encode the data as a Unicode BE (Big Endian) formatted stream. The constant <code>WC_FORMAT_UNICODE_BE</code> is defined as a value of 2 for specifying this format. 3 UTF-8: Encode the data as a UTF-8 formatted stream. The constant <code>WC_FORMAT_UTF8</code> is defined as a value of 3 for specifying this format. 4 TP: Encode the data for use with the UNI TP command. The constant <code>WC_FORMAT_TP</code> is defined as a value of 4 for specifying this format. <code>Stat</code>: Position in <code>STRING</code> from which to start reading <p>Result:</p> <p>Result is a <code>CHAR</code> array containing the encoded Unicode data.</p> <pre>cData = WC_ENCODE(wcMyString, WC_FORMAT_UNICODE,1)</pre>

Unicode Keywords (Cont.)	
WC_FILE_CLOSE	<p>This function closes a file opened with <code>WC_FILE_OPEN</code>. This function should be called when all reading or writing to the file is completed.</p> <pre>SLONG WC_FILE_CLOSE (LONG hFile)</pre> <p>Parameters:</p> <ul style="list-style-type: none"> • <code>hFile</code>: Handle to the file returned by <code>WC_FILE_OPEN</code>. <p>Result:</p> <ul style="list-style-type: none"> 0: Operation was successful -1: Invalid file handle -5: Disk I/O error -7: File already closed <p>There is a limit to the number of file handles available from the system. If files are not closed, it may not be possible to open a file.</p> <pre>Result = WC_FILE_CLOSE (hFile)</pre>
WC_FILE_OPEN	<p>This function opens a file for reading or writing.</p> <pre>SLONG FILE_OPEN (CHAR FilePath[], LONG IOFlag, LONG Format)</pre> <p>Parameters:</p> <ul style="list-style-type: none"> • <code>FilePath</code>: String containing the path to the file to be opened • <code>IOFlag</code>: <ul style="list-style-type: none"> 1 Read: The file is opened with <i>read only</i> status. The constant <code>FILE_READ_ONLY</code> is defined as a value of 1 for specifying this flag. 2 R/W New: The file is opened with <i>read write</i> status. If the file currently exists, its contents are erased. The constant <code>FILE_RW_NEW</code> is defined as a value of 2 for specifying this flag. 3 R/W Append: The file is opened with <i>read write</i> status. The current contents of the file are preserved and the file pointer is set to point to the end of the file. The constant <code>FILE_RW_APPEND</code> is defined as a value of 3 for specifying this flag. • <code>Format</code>: <ul style="list-style-type: none"> 1 Unicode: The file is opened as a Unicode formatted file. If the file is opened as Read or R/W Append and the file is a Unicode formatted file, this parameter will be set to this value by the function. The constant <code>WC_FORMAT_UNICODE</code> is defined as a value of 1 for specifying this format. 2 Unicode BE: The file is opened as a Unicode BE (big Endian) formatted file. If the file is opened as Read or R/W Append and the file is a Unicode BE formatted file, this parameter will be set to this value by the function. The constant <code>WC_FORMAT_UNICODE_BE</code> is defined as a value of 2 for specifying this format. 3 UTF-8: The file is opened as a UTF-8 formatted file. If the file is opened as Read or R/W Append and the file is a UTF-8 formatted file, this parameter will be set to this value by the function. The constant <code>WC_FORMAT_UTF8</code> is defined as a value of 3 for specifying this format. <p>If the open operation is successful, this function returns a non-zero integer value representing the handle to the file. This handle must be used in subsequent read, write, and close operations.</p> <ul style="list-style-type: none"> >0: Handle to file (open was successful) -2: Invalid file path or name -3: Invalid value supplied for IOFlag -5: Disk I/O error -14: Maximum number of files are already open (max is 10) -15: Invalid file format <p>If the file is opened successfully, it must be closed after all reading or writing is completed, by calling <code>WC_FILE_CLOSE</code>. If files are not closed, subsequent file open operations may fail due to the limited number of file handles available.</p> <pre>// Open MYFILE.TXT for readingINTEGER nFormatSLONG hFilehFile = WC_FILE_OPEN('MYFILE.TXT', FILE_READ_ONLY,nFormat) // nFormat will be set to detected file type</pre>
WC_FILE_READ	<p>This function reads a block of widechar data from the specified file.</p> <pre>SLONG WC_FILE_READ (LONG hFile, WIDECHAR Buffer[], LONG BufLen)</pre> <p>Parameters:</p> <ul style="list-style-type: none"> • <code>hFile</code>: Handle to the file returned by <code>WC_FILE_OPEN</code> • <code>Buffer</code>: Buffer to hold the data to be read • <code>BufLen</code>: Maximum number of characters to read <p>Result:</p> <ul style="list-style-type: none"> >0: The number of bytes actually read -1: Invalid file handle -5: Disk I/O error -6: Invalid parameter -9: End-of-file reached <p>This function reads (from the current location of the file pointer) the number of characters specified by <code>BufLen</code> (or fewer bytes if the end of file is reached). The characters are read from the file identified by <code>hFile</code> and are stored in <code>Buffer</code>. The file pointer will automatically be advanced the correct number of bytes so the next read operation continues where the last operation left off.</p> <pre>WIDECHAR wcBuffer[1024]nBytes = WC_FILE_READ (hFile, wcBuffer, 1024)</pre>

Unicode Keywords (Cont.)	
WC_FILE_READ_LINE	<p>This function reads a line of widechar data from the specified file.</p> <pre>SLONG WC_FILE_READ_LINE (LONG hFile, WIDECHAR Buffer[], LONG BufLen)</pre> <p>Parameters:</p> <ul style="list-style-type: none"> • hFile: Handle to the file returned by <code>WC_FILE_OPEN</code> • Buffer: Buffer to hold the data to be read • BufLen: Maximum number of characters to read <p>Result:</p> <ul style="list-style-type: none"> • =0: The number of bytes actually read • -1: Invalid file handle • -5: Disk I/O error • -6: Invalid parameter (buffer length must be greater than zero) • -9: End-of-file reached <p>This function reads from the current location of the file pointer up to the next carriage return or to the end-of-file (EOF), whichever comes first. A complete line will not be read if the buffer length is exceeded before a carriage return (or EOF) is encountered. The characters are read from the file identified by <code>hFile</code> and are stored in <code>Buffer</code>. The <CR> or <CR><LF> pair will not be stored in <code>Buffer</code>.</p> <p>If a complete line is read, the file pointer is advanced to the next character in the file after the <CR> or <CR><LF> pair or to the EOF if the last line was read.</p> <pre>WIDECHAR wcBuffer[80]nBytes = WC_FILE_READ_LINE (hFile, wcBuffer,80)</pre>
WC_FILE_WRITE	<p>This function writes a block of widechar data to the specified file.</p> <pre>SLONG WC_FILE_WRITE (LONG hFile, WIDECHAR Buffer[], LONG BufLen)</pre> <p>Parameters:</p> <ul style="list-style-type: none"> • hFile: Handle to the file returned by <code>WC_FILE_OPEN</code>. • Buffer: Buffer containing the data to write. • BufLen: Number of characters to write. <p>Result:</p> <ul style="list-style-type: none"> • >0: The number of bytes actually written • -1: Invalid file handle • -5: Disk I/O error • -6: Invalid parameter (buffer length must be greater than zero) • -11: Disk full. The data will overwrite or append to the current contents of the file depending on the current position of the file pointer. <pre>WIDECHAR wcBuffer[1024]Result = WC_FILE_WRITE (hFile, wcBuffer,1024)</pre>
WC_FILE_WRITE_LINE	<p>This function writes a line of widechar data to the specified file.</p> <pre>SLONG FILE_WRITE_LINE (LONG hFile, WIDECHAR Line[], LONG LineLen)</pre> <p>Parameters:</p> <ul style="list-style-type: none"> • hFile: Handle to the file returned by <code>WC_FILE_OPEN</code>. • Line: Buffer containing the line of data to write. • LineLen: Number of characters to write. <p>Result:</p> <ul style="list-style-type: none"> • >0: The number of bytes actually written • -1: Invalid file handle • -5: Disk I/O error • -6: Invalid parameter (LineLen must be greater than zero) • -11: Disk full. A <CR><LF> character pair is automatically appended to the end of the line. <pre>WIDECHAR wcLine[80]Result = FILE_WRITE_LINE (hFile, wcLine, 80)</pre>
WC_FIND_STRING	<p>This function searches through a string for a specified sequence of characters.</p> <pre>INTEGER WC_FIND_STRING (WIDECHAR STRING[], WIDECHAR Seq[], INTEGER Start)</pre> <p>Parameters:</p> <ul style="list-style-type: none"> • STRING: The string of character to search. • Seq: The sequence of characters to search for. • Start: The starting character position for the search. <p>Result:</p> <p>A 16-bit unsigned integer representing the character location of <code>Seq</code> in <code>STRING</code>. If the character string is found at the beginning of the string, this function returns 1; any error condition returns 0.</p> <pre>POS = WC_FIND_STRING (STRING, _WC('ABC'), 1)</pre>
WC_GET_BUFFER_CHAR	<p>This keyword removes a character from a buffer.</p> <pre>WIDECHAR WC_GET_BUFFER_CHAR (WIDECHAR A[])</pre> <p>The result is a <code>WIDECHAR</code> value.</p> <p><code>WC_GET_BUFFER_CHAR</code> has a two-part operation:</p> <ol style="list-style-type: none"> 1. Retrieve the first character in the buffer. 2. Remove the retrieved character from the buffer and shift the remaining characters by one to fill the gap. <pre>wchChar = GET_BUFFER_STRING(wcString) // wchChar contains first character of wcString // wcString is now one character smaller in length and // starts with what used to be the 2nd character</pre>

Unicode Keywords (Cont.)	
WC_GET_BUFFER_STRING	<p>This function removes characters from a buffer.</p> <pre>WIDECHAR WC_GET_BUFFER_STRING (WIDECHAR A[], Length)</pre> <p>Length is the number of characters to remove.</p> <p>Result is a WIDECHAR value.</p> <p>WC_GET_BUFFER_STRING has a two-part operation:</p> <ol style="list-style-type: none"> 1. Retrieve <length> number of characters from the buffer. 2. Remove the retrieved character from the buffer and shift the remaining characters up to fill the gap. <pre>wcSubStr = GET_BUFFER_STRING(wcString,3) // wcSubStr contains first 3 characters of wcString // wcString is now three characters smaller in length and // starts with what used to be the 4th character</pre>
WC_LEFT_STRING	<p>This function returns the specified number of characters from the beginning of a string.</p> <pre>WIDECHAR[] WC_LEFT_STRING (WIDECHAR STRING[], LONG Count)</pre> <p>Parameters:</p> <ul style="list-style-type: none"> • STRING: The string from which to extract the characters. • Count: The number of character to copy from the beginning of the string. <p>Result:</p> <p>A string containing a copy of the first Count characters from STRING.</p> <pre>wcSTRING = _WC('ABCDEFGH')wcSubstr = WC_LEFT_STRING(wcSTRING, 3) // wcSubstr = 'ABC'</pre>
WC_LENGTH_STRING	<p>This function returns the length of a WIDECHAR string. This function is provides the same information as LENGTH_ARRAY (page 32).</p> <pre>LONG WC_LENGTH_STRING (WIDECHAR STRING[])</pre> <p>Parameters:</p> <ul style="list-style-type: none"> • STRING: The input character string. <p>Result:</p> <p>The result is the length of STRING. The string length can be set implicitly through a literal or variable string assignment or explicitly by calling SET_LENGTH_STRING.</p> <p>For example:</p> <pre>IF (WC_LENGTH_STRING(wcSTRING) > 0){// process string}</pre>
WC_LOWER_STRING	<p>This function changes all alphabetic characters in the specified string to lower case using the case mapping defined by Unicode.org.</p> <pre>WIDECHAR[] WC_LOWER_STRING (WIDECHAR STRING[])</pre> <p>Parameters:</p> <ul style="list-style-type: none"> • STRING: The WIDECHAR string to convert to lower case. <p>Result:</p> <p>The result is the converted WIDECHAR string.</p> <pre>wcLCString = WC_LOWER_STRING(wcSTRING)</pre>
WC_MAX_LENGTH_STRING	<p>This function returns the dimensioned length of a WIDECHAR string. This function provides the same information as MAX_LENGTH_ARRAY (page 32).</p> <pre>LONG WC_MAX_LENGTH_STRING (WIDECHAR STRING[])</pre> <p>Parameters:</p> <ul style="list-style-type: none"> • STRING: The input widechar string. <p>Result:</p> <p>The result is the dimensioned length of STRING.</p> <pre>MAXLEN = WC_MAX_LENGTH_STRING(wcSTRING)Len = WC_LENGTH_STRING(wcSTRING) IF (MAXLEN > Len){// append character to wcSTRING}</pre>
WC_MID_STRING	<p>This function returns the specified number of characters, starting at the specified location in the source string.</p> <pre>WIDECHAR[] WC_MID_STRING (WIDECHAR STRING[], LONG Start, LONG Count)</pre> <p>Parameters:</p> <ul style="list-style-type: none"> • STRING: The input character string. • Start: Starting location in the string. • Count: Number of characters to extract. <p>Result:</p> <p>The result is a widechar string containing the specified characters.</p> <pre>wcSTRING = _WC('ABCDEFGHIJK')wcSubstr = WC_MID_STRING(wcSTRING, 5, 4)// wcSubstr = 'EFGH'</pre>
WC_REMOVE_STRING	<p>This function removes characters from the specified string. All characters up to and including the first occurrence of the specified sequence are removed.</p> <pre>WIDECHAR[] WC_REMOVE_STRING (WIDECHAR STRING[], WIDECHAR Seq[], LONG Start)</pre> <p>Parameters:</p> <ul style="list-style-type: none"> • STRING: String from which to find and remove characters. • Seq: Sequence of characters to find. • Start: Starting position in the string to begin search. <p>Result:</p> <p>The result is a string containing the removed characters. If the character sequence was not found, an empty string is returned.</p> <pre>wcSTRING = _WC('ABCDEF')wcSubstr = WC_REMOVE_STRING(wcSTRING, _WC('BC'), 1) // wcSubstr = 'ABC'// wcSTRING = 'DEF'</pre>

Unicode Keywords (Cont.)	
WC_RIGHT_STRING	<p>Returns the specified number of characters from the end of a string.</p> <pre>WIDECHAR[] WC_RIGHT_STRING (WIDECHAR STRING[], LONG Count)</pre> <p>Parameters:</p> <ul style="list-style-type: none"> • STRING: The string from which to extract the characters. • Count: The number of character to copy from the end of the string. <p>Result:</p> <p>The return is a string containing a copy of the last <code>Count</code> characters from <code>STRING</code>.</p> <pre>wcSTRING = _WC('ABCDEFGH') wcSubstr = WC_RIGHT_STRING(wcSTRING, 3) // wcSubstr = 'EFG'</pre>
WC_SET_LENGTH_STRING	<p>This function sets the length of a <code>WIDECHAR</code> string. This function provides the same functionality as <code>SET_LENGTH_ARRAY</code> (page 32).</p> <pre>LONG WC_SET_LENGTH_STRING (WIDECHAR STRING[], LONG Len)</pre> <p>Parameters:</p> <ul style="list-style-type: none"> • STRING: The input widechar string. • Len: The new string length. <pre>WC_SET_LENGTH_STRING(wcSTRING, 10)</pre>
WC_TO_CH	<p>This keyword converts a <code>WIDECHAR</code> array to a <code>CHAR</code> array.</p> <pre>CHAR[] WC_TO_CH (WIDECHAR wcSTRING[])</pre> <p>Parameters:</p> <ul style="list-style-type: none"> • STRING: The widechar string to convert to a character string. <p>Result:</p> <p>A character string version of the widechar string.</p> <p>All characters that require more than 8 bits of storage are converted to the '?' character.</p> <pre>cData= WC_TO_CH (_WC('Unicode'))</pre>
WC_TP_ENCODE	<p>This function encodes a <code>WIDECHAR</code> array into a <code>CHAR</code> array formatted for the UNI and BAU user interface commands.</p> <pre>CHAR[] WC_TP_ENCODE (WIDECHAR STRING[])</pre> <p>Parameters:</p> <ul style="list-style-type: none"> • STRING: The widechar string to send to a user interface. <p>Result:</p> <p>The result is an encoded character string.</p> <pre>cString = WC_TP_ENCODE(wcSTRING) SEND_COMMAND dvTY, "'^UNI-1,0,' ,cString"</pre>
WC_UPPER_STRING	<p>This function changes all alphabetic characters in the specified string to upper case using the case mapping specified by <code>Unicode.org</code>.</p> <pre>WIDECHAR[] WC_UPPER_STRING (WIDECHAR wcSTRING[])</pre> <p>Parameters:</p> <ul style="list-style-type: none"> • STRING: The widechar string to convert to upper case. <p>Result:</p> <p>The result is the converted widechar string.</p> <pre>wcUCString = WC_UPPER_STRING(wcSTRING)</pre>

Variables Keywords

Overview

NetLinx defaults non-array variables to the integer data types and defaults array variables to character data type array. The variable must be explicitly declared if using any other data type. NetLinx provides support for several different types of variables distinguished by attributes, such as:

- Scope
- Constancy
- Persistence

Scope

Scope is a term used in reference to program variables that describe where in the program they can be accessed. There are two types:

- **Local scope:** a variable can only be accessed in the subroutine or method that it is declared.
- **Global scope:** a variable can be accessed anywhere in the program.

Scope differentiates the two basic classes of NetLinx variables:

- **Local variable:** a variable declared within a subroutine or function whose scope is limited to that subroutine or function.
- **Global variable:** a variable declared in the `DEFINE_VARIABLE` section; its scope extends throughout the module in which it is declared.

Local Variables

Local variables are restricted in scope to the statement block in which they are declared. A statement block is one or more NetLinx statements enclosed in a pair of braces, like the blocks following subroutines, functions, conditionals, loops, waits, and so on. Local variables must be declared immediately after the opening brace of a block but before the first executable statement. To provide compatibility with the Access language, local variables may be declared right before the opening brace for `DEFINE_CALL` declarations only. For example, both formats shown below are legal in NetLinx:

```
DEFINE_CALL 'My Subroutine' (INTEGER INT1)
  LOCAL_VAR INTEGER INT2
  {
      (* body of subroutine *)
  }

DEFINE_CALL 'My Subroutine' (INTEGER INT1)
{
  LOCAL_VAR INTEGER INT2
  (* body of subroutine *)
}
```

The scope of a local variable is restricted to the statement block in which it is declared. A local variable is either static or non-static, depending on whether it is declared as `LOCAL_VAR` (page 153) or `STACK_VAR` (page 154).

NOTE: A static variable maintains its value throughout the execution of the program, regardless of whether it is within scope of the current program instruction.

- The keyword `LOCAL_VAR` specifies a static variable. A static variable's value is initialized the first time the statement block in which it is declared is executed and retained after execution of the statement block has finished.
- The `STACK_VAR` keyword specifies a non-static variable. A non-static variable's value is re-initialized every time the statement block in which it is declared is executed.
- If neither the `LOCAL_VAR` nor the `STACK_VAR` keyword is specified, `STACK_VAR` is assumed (default).

```
IF (X > 10)
{
  LOCAL_VAR INTEGER INT2          // static (permanent)
  STACK_VAR CHAR ARRAY1[10]      // non-static (temporary)
  (* statements *)
}
```

NOTE: Variable declarations outside of `DEFINE_VARIABLE` will default to `STACK_VAR` if neither "local" or "stack" is specified.

`LOCAL_VAR` and `STACK_VAR` can be used interchangeably in any statement block except for waits. Only `LOCAL_VAR` variables may be declared inside a wait block.

```
WAIT 10, 'My Wait Name'
{
  LOCAL_VAR CHAR TempBuf[80]
  (* statements *)
}
```

A name assigned to a local variable must be unique within the statement block in which it is declared and any statement block enclosing that block. Therefore, non-nested statement blocks can define the same local variable name without conflict. For example:

```

DEFINE_FUNCTION integer MyFunc(INTEGER nFlag)
{
    LOCAL_VAR INTEGER n
    IF (nFlag > 0)
    {
        LOCAL_VAR INTEGER n          // illegal declaration
        .
        .
    }
    .
    .
}

DEFINE_FUNCTION integer MyFunc(INTEGER nFlag)
{
    IF (nFlag > 0)
    {
        LOCAL_VAR INTEGER n
        .
        .
    }
    else
    {
        LOCAL_VAR INTEGER n          // legal declaration
    }
}

```

The general form of a static local variable declaration is:

```
[LOCAL_VAR] [VOLATILE | PERSISTENT] [CONSTANT] [<type>] name
```

The general form of the non-static local variable declaration is:

```
[STACK_VAR] [<type>] name
```

Since non-static local variables are allocated on the program stack (a block of memory reserved for allocation of temporary variables), the keywords `VOLATILE` (page 154), `PERSISTENT` (page 154), and `CONSTANT` (page 153) do not apply.

Global Variables

Global variables are defined in the `DEFINE_VARIABLE` (page 63) section of any program module.

For example:

```

DEFINE_VARIABLE
CONSTANT INTEGER MAXLEN = 64
CHAR STR[MAXLEN] = 'No errors were found.'
INTEGER ARRAY[ ] = {100, 200, 300}

```

A global variable is accessible throughout the module or program in which it is defined. Global variables retain their value as long as the program runs. They may retain their value after powering down or reloading the system, depending on the variable's persistence attributes (`VOLATILE` and `PERSISTENT`).

If a local variable shares the same name as a global variable, the local variable always takes precedence.

The general form of a global variable definition is:

```
[NON_VOLATILE | VOLATILE | PERSISTENT] [CONSTANT] [<type>] name [= <value>]
```

Constancy

Any variable may also be assigned the attribute `CONSTANT`(page 153). This declares a variable to be immutable (cannot change at run-time). The variable must be initialized as part of its declaration if this keyword is used.

Persistence

The persistence of a variable is controlled through the `NON_VOLATILE` (page 154), `VOLATILE` (page 154), and `PERSISTENT` (page 154) keywords.

Non-Volatile Variables

A variable declared with the `NON_VOLATILE` keyword is stored in non-volatile memory. It will retain its value in the event of a system power-down, but is reset to zero if the program is reloaded. Unless specified otherwise, all variables are stored in non-volatile memory.

Volatile Variables

A variable declared with the `VOLATILE` keyword is stored in volatile memory and resets to zero after either a power-down or reload. Volatile memory is generally faster and more plentiful than non-volatile memory. For this reason, you should use the `VOLATILE` keyword when declaring large data arrays where persistence of the data is not a requirement.

Persistent Variables

If a variable is declared with the `PERSISTENT` keyword, it is initialized to zero the first time the program is loaded but will retain its value after either power-down or reload. If the data type is omitted from the variable definition, the following defaults are assumed:

- Single variables are `PERSISTENT` type.
- Arrays are `CHAR` type.

You can define a variable to be persistent using the PERSISTENT storage modifier as shown below:

```
DEFINE_VARIABLE
PERSISTENT CHAR cMyString[100]
```

All persistent variables are automatically non-volatile, and it's not legal to define a variable as VOLATILE and PERSISTENT. Any time *after* a NetLinx program that has a persistent variable declared subsequent downloads of new NetLinx programs that contain the same persistent variable will automatically be set to contain the same value as it previously did. By default, non-persistent variables are set to zero after a NetLinx program downloads. Persistence overrides this behavior by setting the variable in the newly downloaded program to be the same as it was before the download.

Typically, persistent variables are used for saving preset information. Suppose you have a system that contains several PosiTrack camera positioning systems and that the user interface to the system allows the user to set the position of any of the cameras and record that position for recalling later. The position presets are stored in a non-volatile array variable so they are maintained during a power cycle. Without persistent variables, an update to the NetLinx program would zero out all of the presets that the user had stored. With persistent variables, the new NetLinx program can be downloaded and all of the presets remain intact.

When a new NetLinx program is downloaded to the Master, the Master iterates through all non-volatile variables from the new program looking for persistent ones. When it finds a persistent variable in the new program, it searches the old programs persistent variable space for the "same variable". When it finds the same variable, the value of the new variable is set to the same value as the old programs variable. It is important to note what is considered to be the "same variable".

The master identifies the "same variable" by verifying for duplicity the following:

- Variable name
- Variable source location
- Variable type

Therefore, in order for persistence to function properly, the name, type, and file declared in must be the same as the previously downloaded NetLinx program. If you changed any of the three, the new persistent variable will not be set with the old variable's value.

Constants

Constants are defined in the DEFINE_CONSTANT (page 61) section.

Variables Keywords

The NetLinx programming language supports the following Variables keywords:

Variables Keywords	
ABS_VALUE	<p>ABS_VALUE provides the absolute value of a variable. It will take any intrinsic variable type and return the same type.</p> <pre>AbsVal ABS_VALUE (Value)</pre> <pre>DEFINE_VARIABLE SLONG Var1, Var2 DEFINE_START Var1 = -1 DEFINE_PROGRAM Var2 = ABS_VALUE(Var1) // Var2 = 1</pre>
CONSTANT	<p>This keyword is used as part of a variable declaration to specify that the variable cannot be changed at run-time. If a variable is declared with this keyword, it must be initialized in its declaration.</p>
LOCAL_VAR	<p>This keyword specifies a variable that is static. To provide compatibility with the Axxess language, local variables may be declared right before the opening brace for DEFINE_CALL declarations only. If neither the LOCAL_VAR nor the STACK_VAR keyword is specified, STACK_VAR is assumed.</p> <p>See the <i>Variables - Overview</i> on page 9 for more information.</p>
MAX_VALUE	<p>Provides the value of the highest of two variables. It will take any intrinsic variable type and return the same type of the highest variable.</p> <pre>MaxVal MAX_VALUE (Var1,Var2) DEFINE_VARIABLE SLONG Var1, Var2, VarMax DEFINE_START Var1 = 100 Var2 = 200 DEFINE_PROGRAM VarMax = MAX_VALUE (Var1,Var2) // VarMax = 200</pre>
MIN_VALUE	<p>Provides the value of the lowest of two variables.</p> <p>It will take any intrinsic variable type and return the same type of the lowest variable.</p> <pre>MinVal MIN_VALUE (Var1,Var2) DEFINE_VARIABLE SLONG Var1, Var2, VarMin DEFINE_START Var1 = 100 Var2 = 200 DEFINE_PROGRAM VarMin = MIN_VALUE (Var1,Var2) // VarMin = 100</pre>

Variables Keywords (Cont.)	
NON_VOLATILE	A variable declared with the <code>NON_VOLATILE</code> keyword is stored in non-volatile memory. It retains its value in the event of a system power-down, but is reset to zero if the program is reloaded. Unless specified otherwise, all variables are stored in non-volatile memory.
OFF	See page 37
ON	See page 37
PERSISTENT	If a variable is declared with the <code>PERSISTENT</code> keyword, it is initialized to zero the first time the program is loaded but will retain its value after power-down or reload. <ul style="list-style-type: none"> The <code>PERSISTENT</code> attribute does not apply to non-static local variables, since non-static local variables are allocated on the program stack (a block of memory reserved for allocation of temporary variables). The <code>PERSISTENT</code> attribute does not apply to the individual members of a structure.
RANDOM_NUMBER	This function returns a random number X in the range $0 \leq X < \text{Max}$. <code>LONG RANDOM_NUMBER (LONG Max)</code> Parameters: <ul style="list-style-type: none"> <code>Max</code>: An unsigned long integer (must be greater than zero) that will serve as the upper limit for the random number generator. The result is an unsigned long integer ≥ 0 and $< \text{Max}$. <code>Num = RANDOM_NUMBER(1000) // 0 <= Num < 1000</code>
STACK_VAR	This keyword specifies a non-static variable. A non-static variable's value is re-initialized every time the statement block in which it is declared is executed. References to <code>STACK_VAR</code> variables are not allowed within waits. <code>STACK_VARS</code> are temporary variables that cease to exist when the block in which they are declared is exited. If neither the <code>LOCAL_VAR</code> nor the <code>STACK_VAR</code> keyword is specified, <code>STACK_VAR</code> is assumed.
TOTAL_OFF	See page 37.
TYPE_CAST	This routine eliminates compiler type cast warnings by casting the passed intrinsic variable type to the type assigned by the return value. <code>IntrinsicVariableNewType TYPE_CAST (IntrinsicVariableType)</code> It is possible to eliminate the compiler warnings related to type casting. The <code>TYPE_CAST</code> library function converts any non-array intrinsic type to any other non-array intrinsic type. The type conversion still happens and follows the standard Type Conversion Rules, but any warnings related to the type cast are eliminated. Type casting causes potential loss of data when a variable or constant is assigned to a variable of smaller type.
VOLATILE	This keyword is used as part of a variable declaration to specify that storage space for the variable be allocated in volatile memory. Variables stored in volatile memory are not retained when the system is powered-down, as are variables stored in non-volatile memory. The trade-off is that volatile memory is generally more plentiful and therefore a good choice for storing large data arrays.

Wait Keywords

Overview

Wait instructions allow delayed execution of one or more program statements. When a wait statement is executed, it is added to a list of currently active wait requests and the program continues running.

Types of Waits

Types of Wait statements include:

- **Timed Waits** have an associated parameter that indicates the amount of time that must elapse before the associated wait instruction(s) are to be executed. See page 156.
- **Conditional Waits** require that a specified condition be met before the instructions are executed. See page 156.
- **Timed Conditional Waits** have a timeout parameter; if the condition is not met before the specified time elapses, the wait request is canceled. See page 156.

Naming Waits

Supplying a unique name in the wait statement allows the wait to be identified for purposes of canceling, pausing, or restarting the wait request. The name must not conflict with previously defined constants, variables, buffers, subroutines, or functions. Unlike other NetLinx identifiers, wait names may contain spaces. If a wait instruction that uses a name currently in the wait list is encountered, the new wait instruction is thrown away so as not to conflict with the one currently in progress. If this feature is not desired, the current wait must be canceled before processing the new request.

Nesting Waits

The wait time for a nested wait is the sum of it's own wait time, plus that of the enclosing waits. In the example below, SECOND WAIT occurs 0.5 seconds after FIRST WAIT is executed, or 1.5 seconds after FIRST WAIT is added to the wait list.

```
WAIT 10 'FIRST WAIT'
{
    (* FIRST WAIT statements *)
    WAIT 5 'SECOND WAIT'
    {
        (* SECOND WAIT statements *)
    }
}
```

To execute the inner wait of a nested conditional wait, the conditions must be met in the order specified (condition 1, then condition 2) but not necessarily at the same time.

```
WAIT_UNTIL <condition 1> 'FIRST WAIT'
{
    (* FIRST WAIT statements *)
    WAIT_UNTIL <condition 2> 'SECOND WAIT'
    {
        (* SECOND WAIT statements *)
    }
}
```

Using Waits - Limitations

- References to STACK_VAR variables are not allowed within waits (STACK_VAR are temporary variables that cease to exist when the block in which they are declared is exited).
- Variable copies are made of functions and subroutine parameters. This can have speed/execution penalties.
- A RETURN is not allowed within a WAIT within functions and subroutines.
- A BREAK or CONTINUE cannot appear within a WAIT if it takes execution out of the scope of the WAIT.
- The code within a WAIT cannot reference a function or subroutine array parameter whose bounds are unspecified.

WAIT keywords

The NetLinx programming language supports the following WAIT keywords:

WAIT Keywords	
CANCEL_ALL_WAIT	This keyword cancels all WAITS (named or unnamed) from the appropriate Wait list. Syntax: CANCEL_ALL_WAIT
CANCEL_ALL_WAIT_UNTIL	This keyword cancels all WAIT_UNTILs and TIMED_WAIT_UNTILs (named or unnamed) from the appropriate Wait list. Syntax: CANCEL_ALL_WAIT_UNTIL
CANCEL_WAIT	This keyword removes the wait specified by name from the appropriate wait list. Syntax: CANCEL_WAIT '<wait name>

WAIT Keywords (Cont.)	
CANCEL_WAIT_UNTIL	<p>This keyword cancels a specified <code>WAIT_UNTIL</code> or <code>TIMED_WAIT_UNTIL</code>. Only named <code>WAIT_UNTIL</code> and named <code>TIMED_WAIT_UNTIL</code> commands can be canceled.</p> <p>Syntax:</p> <pre>CANCEL_WAIT_UNTIL '<wait name>'</pre>
PAUSE_ALL_WAIT	<p>This keyword suspends all <code>WAIT</code>s currently in effect.</p> <p>Syntax:</p> <pre>PAUSE_ALL_WAIT</pre> <p><code>PAUSE_ALL_WAIT</code> is used to pause all scheduled waits, regardless of whether or not they are named. They have no parameters.</p>
PAUSE_WAIT	<p>Puts a scheduled wait on hold. The wait being paused is identified by the parameter name. The wait timer stops counting down until it is resumed with a <code>RESTART_WAIT</code> command.</p> <p>Syntax:</p> <pre>PAUSE_WAIT '<wait name>'</pre> <p>This keyword suspends the specified (named) <code>WAIT</code> until a <code>RESTART_WAIT</code>, <code>RESTART_ALL_WAIT</code>, <code>CANCEL_WAIT</code>, or <code>CANCEL_ALL_WAIT</code> command is issued.</p>
RESTART_ALL_WAIT	<p>This command resumes all waits that were previously paused. This includes both named and unnamed waits.</p> <p>Syntax:</p> <pre>RESTART_ALL_WAIT</pre>
RESTART_WAIT	<p><code>RESTART_WAIT</code> resumes the countdown for a wait suspended with <code>PAUSE_WAIT</code>. The wait to be restarted is identified by the parameter name.</p> <p>Syntax:</p> <pre>RESTART_WAIT '<name>'</pre>
WAIT	<p>This keyword delays execution of one or more statements for a specified period of time.</p> <p>Syntax:</p> <pre>WAIT time ['<name>'] { (* wait statements *) }</pre> <p>Parameters:</p> <ul style="list-style-type: none"> <code>time</code>: A constant or variable indicating the wait time. Time is expressed in 1/10th second units. The statement below specifies a wait time of 5 seconds for the wait named <code>FIRST_WAIT</code>. <code><name></code>: The name to assign to the wait. This name must be a literal string. The wait name is optional, although unless a wait is named it cannot be individually canceled, paused, or restarted. <p>If greater precision is required, the time parameter can be expressed as a decimal fraction, for example 0.1 to specify a wait time of 1/100th of a second. The range is 0.1 to 0.9.</p> <pre>WAIT 50 'FIRST_WAIT' { (* wait statements *) }</pre>
WAIT_UNTIL	<p>This is a conditional Wait request. This keyword is used to delay execution of one or more statements until a specified condition is met.</p> <p>Syntax:</p> <pre>WAIT_UNTIL <condition> ['<name>'] { (* wait statements *) }</pre> <p>Parameters:</p> <ul style="list-style-type: none"> <code><condition></code>: Any single or compound expression that can be evaluated as a logical expression. The Wait statements are executed if and when the wait condition becomes True. <code><name></code>: The name to assign to the Wait. This name must be a literal string. The Wait name is optional, although unless a Wait is named it cannot be individually canceled, paused, or restarted.
TIMED_WAIT_UNTIL	<p>This is a Timed Conditional Wait request. This keyword delays execution of one or more statements until a particular condition is met. It is similar to <code>WAIT_UNTIL</code> except that this instruction provides for a timeout parameter to be specified.</p> <p>Syntax:</p> <pre>TIMED_WAIT_UNTIL <condition> timeout ['<name>'] { (* wait statements *) }</pre> <p>Parameters:</p> <ul style="list-style-type: none"> <code><condition></code>: Any single or compound expression that can be evaluated as a logical expression. The Wait statements are executed if and when the Wait condition becomes true. <code>timeout</code>: A constant or variable indicating the timeout value in 1/10th seconds. If the Wait condition is not met within the time indicated by this parameter, the Wait is canceled, in which case no wait statements are executed. <code><name></code>: The name to assign to the Wait. This name must be a literal string. The Wait name is optional, although unless a Wait is named it cannot be individually canceled, paused, or restarted.

Appendix A - Compiler Warning & Errors

Compiler Warnings

Sometimes the compiler generates a warning message instead of an error message; these warning messages always start with **w**.

- A warning about a particular statement means that the statement is not technically an error, but you should be careful doing it.
- Warnings, unlike errors, do not stop the program from compiling.

Compiler Warnings	
(w) Cannot assign unlike types	<p>This warning occurs when a variable or value of one type is assigned to a variable of a different type. Here are some examples:</p> <ul style="list-style-type: none"> • Assigning a string literal, string expression, or array to a non-array variable • Assigning a non-array variable to an entire array • Assigning an integer array to a non-integer array • Assigning a two-dimensional array to a one-dimensional array, or vice versa • Assigning the result of a function that returns an array type to a non-array variable or to a two-dimensional array variable (for example, <code>X = ITOA(12)</code>, where <code>X</code> is a non-array variable or two-dimensional array variable) • Assigning the result of a function that returns a non-array type to a one- or two-dimensional array variable (for example, <code>X = ATOI('AMX')</code>, where <code>X</code> is a one- or two-dimensional array variable) <p>This message is a warning and not an error, because <code>X = ITOA(12)</code> works correctly when <code>X</code> is a simple variable, since the result is a single value between 0 and 65,535.</p>
(w) DEFINE_CALL is not used	This warning occurs at the end of program compilation for each <code>DEFINE_CALL</code> (page 58) subroutine that was declared but never used.
(w) Integer applies to arrays only	This warning appears when the keyword <code>INTEGER</code> (page 55) is applied to a non-array type of variable. Doing this is not an error, because non-array variables are already integers, but it is redundant.
(w) Long_While within While	<p>This warning occurs if the compiler finds a <code>LONG_WHILE</code> (page 53) or <code>MEDIUM_WHILE</code> (page 53) inside a block of code following a <code>WHILE</code> (page 53) keyword. This warning exists because the <code>WHILE</code> command has a 1/2 second timeout period, and the <code>LONG_WHILE</code> and <code>MEDIUM_WHILE</code> keywords do not. This could create a hard-to-find logic error.</p> <p>The solution is to change the <code>WHILE</code> to a <code>LONG_WHILE</code>.</p>
(w) Possibly too many nested levels	<p>This warning appears if there is a large amount of nesting in the program. This can happen with a long chain of <code>IF...ELSE IF</code> statements (page 47).</p> <p>The solution is to use the <code>SELECT...ACTIVE</code> (page 47) set of statements.</p>
(w) Variable is not used	This warning occurs at the end of compilation for each variable that was declared but never used.

Compiler Errors

The compiler informs you when it finds an error during the compilation process. Most of the time these errors occur due to a typographical error or incorrect syntax of a particular command. Unlike warnings, errors must be corrected before your NetLinx program can be executed.

Compiler Errors	
A "<symbol>" was expected	The compiler is expecting a certain symbol at this particular place.
ACTIVE keyword expected	An <code>ACTIVE</code> keyword is not present after a <code>SELECT</code> (page 52) keyword.
Allowed only in DEFINE_START	A keyword that is only allowed to appear in the <code>DEFINE_START</code> (page 62) section of the program was encountered elsewhere.
Attempted CALL to undefined subroutine	A <code>CALL</code> statement refers to a subroutine that has not been defined with a <code>DEFINE_CALL</code> (page 61) statement.
Comment never ends, EOF encountered	A comment begins but never ends. Place a close comment, <code>*</code>) at the end of the unfinished comment.
Conditional compile nesting too deep	There are too many nested <code>#IF_DEFINED</code> (page 29) or <code>#IF_NOT_DEFINED</code> (page 29) conditional compilation statements. The limit is 20 nested conditional compilation statements.
Constant type not allowed	<p>A constant value was declared as latching, toggling, or mutually exclusive, as shown below:</p> <pre>DEFINE_CONSTANT PLAY = 1 DEFINE_LATCHING PLAY (* Error: PLAY is a constant *)</pre>
DEFINE_CALL must have a name	<code>DEFINE_CALL</code> (page 61) must have a name after it. For example, <code>DEFINE_CALL 'VHS'</code> .

Compiler Errors (Cont.)	
DEFINE_CALL name already used	The name of the DEFINE_CALL (page 61) has already been used. This name cannot be the same as an already declared identifier of any type.
Device values must be equal	In a range specification, the devices (or their defined identifiers) must be equal. For example, ([1,1]..[1,5]) is valid; ([1,1]..[2,5]) is not.
Duplicate symbol	Duplicate definitions of variables or constants are found. All variables and constants must have unique identifiers.
Evaluation stack overflow	The expression is too complicated. Try breaking it up into smaller pieces.
Evaluation stack underflow	The expression is too complicated. Try breaking it up into smaller pieces.
Identifier expected	The compiler is expecting an identifier after a #DEFINE (page 29) statement or after an integer declaration in the DEFINE_VARIABLE (page 63) section.
Identifier is not an array type	A non-array variable was treated as an array.
Include file not found	An INCLUDE (page 52) statement was encountered, but the specified include file could not be found.
Invalid include file name	A string literal enclosed in single quotes must follow the INCLUDE (page 52) keyword.
Library file not found	The library file containing the specified SYSTEM_CALL (page 28) could not be found.
Maximum string length exceeded	String literals are limited in length to 132 characters, including spaces.
Must be char array reference	An array type variable was expected in CREATE_BUFFER (page 35), CREATE_MULTI_BUFFER (page 35), or CLEAR_BUFFER (page 35).
Must be integer reference	The identifier in question must be an integer. This error occurs when the third parameter of CREATE_LEVEL (page 103) is an array or array element.
Out of memory	The compiler has run out of memory. Free up memory either by removing any pop-up programs or drivers, by using extended memory, or by breaking your program into one or more Include files.
Parameter mismatch in CALL	A value or variable passed to a CALL (page 28) as a parameter is of the wrong type as defined by the DEFINE_CALL (page 61) statement.
PROGRAM_NAME must be on line 1	Move the PROGRAM_NAME= (page 63) statement to the first line of the program.
Push/Release not allowed within Push/Release	A PUSH (page 121) or RELEASE (page 121) statement was found within a block of code headed by a PUSH or RELEASE statement.
Push/Release not allowed within Wait	These keywords are not allowed in a section of code which will be executed due to a WAIT (page 156) keyword.
PUSH_CHANNEL not allowed within Wait	These keywords are not allowed in a section of code which will be executed due to a WAIT (page 156) keyword.
RELEASE_CHANNEL not allowed within Wait	These keywords are not allowed in a section of code which will be executed due to a WAIT (page 156) keyword.
PUSH_DEVICE not allowed within Wait	These keywords are not allowed in a section of code which will be executed due to a WAIT (page 156) keyword.
RELEASE_DEVICE not allowed within Wait	These keywords are not allowed in a section of code which will be executed due to a WAIT (page 156) keyword.
String constant expected	A string is required for the particular operation. This error occurs if a string literal enclosed in single quotes does not follow the PROGRAM_NAME (page 63) keyword.
String constant never ends, EOF encountered	A string literal is started but never ends. Add a closing single quotation mark (') to the end of the string.
String literal expected	A string is required for the particular operation. This error occurs if a string literal enclosed in single quotes does not follow the #WARN (page 29) keyword.
Subroutine may not call itself	A subroutine (page 26) cannot call itself. It can, however, call a different subroutine.
Syntax error	A syntax error is found in an expression. In most cases, this error means that a character is out of place or something is misspelled.
SYSTEM_CALL name not same as PROGRAM_NAME in <file>	This error occurs when a library file is compiled and the name of the subroutine in the library file does not match the PROGRAM_NAME (page 63) string on the first line of the file.
This variable type not allowed	This error occurs when an attempt is made to use an array variable with DEFINE_LATCHING (page 62), DEFINE_TOGGING (page 62), or DEFINE_MUTUALLY_EXCLUSIVE (page 62).

Compiler Errors (Cont.)	
TO statements that occur outside the data flow of PUSH events/statements may not work	TO is valid: <ul style="list-style-type: none"> Under a PUSH (page 121) statement Under a BUTTON_EVENT/PUSH handler (see page 81) Under a BUTTON_EVENT/HOLD handler (see page 81) In a DEFINE_FUNCTION (page 62) or DEFINE_CALL (page 61) that gets invoked in one of the areas above. In this case, the function or call could be potentially be invoked anywhere in the program. It is an intractable problem to check for misplacement of <i><any possible function name></i> and <i><any possible call name></i>, so TO's outside of PUSH's will not generate an error, just a warning. NOTE: <i>This all applies to MIN_TO (page 121) also.</i>
Too few parameters in CALL	There are not enough parameters being passed to the subroutine.
Too many include files	In NetLinx, the number of Include files allowed is limited only by the amount of memory available on the PC at compile time.
Too many parameters in CALL	There are too many parameters being passed to the subroutine.
Type mismatch in function CALL	A function was called with a parameter of the wrong type. For instance, attempting to use ITOA (page 51) with an array as a parameter will result in an error.
Undefined identifier	An attempt was made to reference an identifier that has not been defined previously in the program.
Unmatched #END_IF	An #END_IF (page 29) keyword was found, but no #IF_DEFINED (page 29) or #IF_NOT_DEFINED (page 29) was previously compiled.
Unrecognized character in input file	An invalid character was found during the build.
Use SYSTEM_CALL [instance] 'name'	This error occurs if a SYSTEM_CALL (page 16) statement is written incorrectly as: SYSTEM_CALL 'NAME' [INSTANCE NUMBER].
Variable assignment not allowed here	Variables may not be assigned a value when they are defined in the DEFINE_VARIABLE (page 63) section.
Wait not found	A statement references a WAIT (page 156) by a name that does not exist. For example, CANCEL_WAIT 'CASS' will produce this error if there is no WAIT named CASS.

Run-Time Errors

In many cases, a program is compiled and sent to the Central Controller error-free, but the system does not act in the way it should. If the program code is correct, you should check for run-time errors. These errors occur in the Central Controller, usually when it could not perform a particular operation in the program.

Run-Time Errors	
Bad assign 2dim...	These errors occur if an attempt is made to assign a two-dimensional array to a different type (such as a variable or one-dimensional array), and vice versa.
Bad assign Call...	These errors occur if the Central Controller cannot assign a parameter in a CALL (page 16) statement to the parameter in the corresponding DEFINE_CALL (page 16) statement.
Bad element assign...	These errors occur if an assignment is attempted past the end of an array, or to the Ø location of an array (for example, ARRAY[Ø]).
Bad Off... Bad On... Bad To...	These errors indicate that the device-channel or variable that is being referenced by an OFF, ON, or TO keyword is out of range.
Bad re-assign Call...	These errors occur when the Central Controller attempts to re-assign the parameter variables in a DEFINE_CALL (page 16) to the parameters in the corresponding CALL (page 16) statement, and the assignment cannot be made.
Bad run token	This error occurs when the Central Controller does not understand a piece of data in the program it is executing.
Bad Set_Length...	These errors occur if the SET_LENGTH_STRING (page 149) keyword tries to set the length value of an array to a value greater than the array's storage capacity.
Bad While	This error occurs whenever a WHILE (page 48) loop terminates due to the half-second timeout imposed on WHILE loops.

Appendix B - Master-To-Master (M2M)

Overview

This section explains the concept of Master-to-Master ("M2M") systems, and provides the information that must be understood to successfully deploy M2M systems. Most M2M systems can be successfully deployed using "route mode direct" and the appropriate topology. These two items are explained in detail in the subsections "Master routing" (page 160) and "Topologies" (page 163).

Master-to-Master

The functionality of M2M consists of master routing and inter-system control. Master routing is the ability to route messages to any other master or device and is the foundation of all M2M functionality. Inter-system control allows a master, or its NetLinX program, to control and get status of any other device (or master) that is connected to any other master. FIG. 7 depicts a typical system of two interconnected NetLinX control systems with several devices connected to each one:

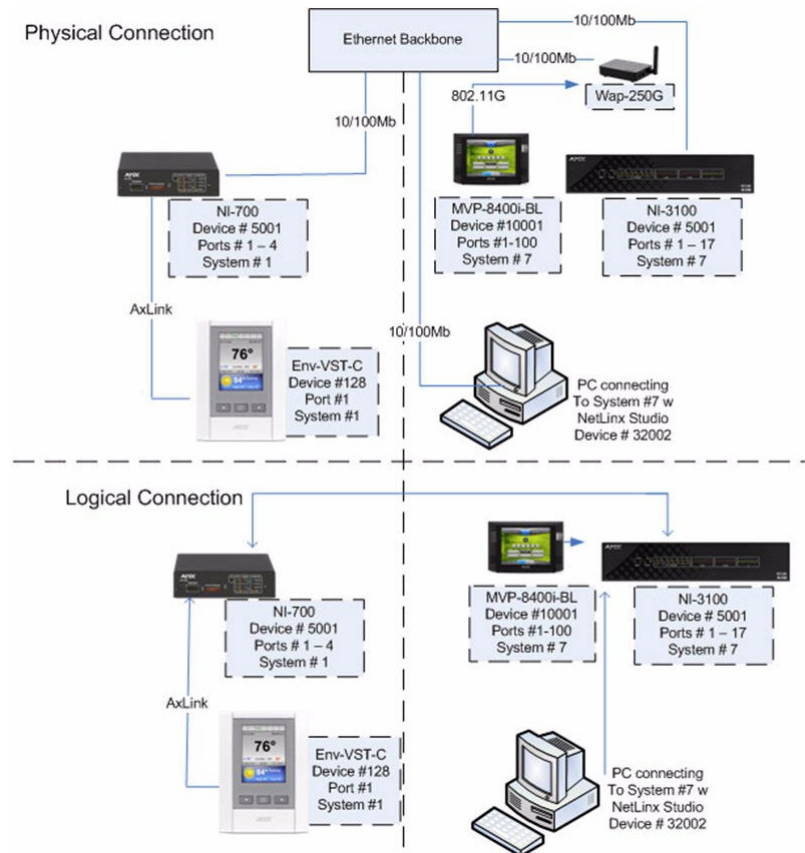

FIG. 7 Two Interconnected Netlinx Control Systems

The top portion of the illustration in FIG. 7 shows the physical connections and the devices represented. The bottom portion shows the logical connections that have been assigned. In this example the NI-3100 will not communicate with the ENV-VST-C unless defined in the `DEFINE_DEVICE` section of its program code running on NI-3100 using the appropriate system number, for example 128:1:1. The first port on the MVP-8400i could be defined on system 1 using 10001:1:7, and on system 7 using 10001:1:7 or 10001:1:0.

Master Routing

By design, all NetLinX masters do not automatically make a M2M connection with other NetLinX masters by virtue of being on the same network. The connection between them must be made intentionally by adding them to a list. This connection list is called the "URL List". The URL List on the NetLinX master is used to force the master to initiate a TCP connection to the specified URL/IP address.

Any TCP/IP device, including NetLinX masters, which utilize DHCP to obtain its TCP/IP configuration, are subject to having their IP address change at any time. Therefore, NetLinX master's IP address must be static unless the network supports Dynamic DNS AND a DHCP server capable of updating the DNS tables on behalf of the DHCP client. If a Dynamic DNS/DHCP server is available then the NetLinX master's host name may be used in the URL List. Therefore, the first step in assembling a M2M system is to set unique system numbers on each master.

- Valid system numbers are **1 - 65535**
- System **0** is a wildcard referring to the local system and is used within `DEFINE_DEVICE` and NetLinX Studio connections

The next step is to configure the URL List in either of the masters, but not both, to point to the other master. For example, in Illustration 1 NetLinx master system #1 could have its URL List configured with a single entry that contains the IP address of the NetLinx master system #7; this will establish a two-way connection.

The system #7 master does not need to have a URL entry to communicate with system #1. If the system #7 master's URL List does contain the IP address for system #1 a routing loop will be created which will lead to problems (FIG. 8).

OK			OK			WRONG		
System Number			System Number			System Number		
URL Entry	Master 1	Master 7	URL Entry	Master 1	Master 7	URL Entry	Master 1	Master 7
1	7		1		1	1	7	1

FIG. 8 Master Routing

Once the systems are connected to each other they exchange routing information such that each master will learn about all the masters connected to each other. The implementation of master routing primarily involves the communication of routing tables between masters. The routing table is built using the entries within the local URL List, the DPS entries in the `DEFINE_DEVICE` section of the code, and from the routing tables exchanged between connected masters. Routing tables are exchanged between masters upon their initial connection and updates to the routing tables are exchanged periodically. Route table transmission has a certain amount of randomization built in to prevent flooding the network with routing table transmissions when a master reports online/offline. Each master in a network will add a minor random delay (1-5 seconds) so that they don't all transmit at the same time.

There is no fixed limit on the number of entries in a routing table. The number of routes is dependent on the number of systems in the network for which there is no set limit. The only limit is the memory space in each master to maintain all of the system information of the various systems throughout the network.

Route Modes (Normal and Direct)

There are two route modes in which masters can be configured to share their routing table. The first and default is *"normal"*, in this mode the master will share the entire routing table built from all interconnected masters. The second is *"direct"*; in this mode the master will share a routing table that only contains itself. When using *"direct"* mode the master will only connect with the masters that are one hop away. As a diagnostic aid, the *"show route"* command can be issued from a telnet session to show paths to other masters. Consider the following system of interconnected NetLinx masters (FIG. 9):

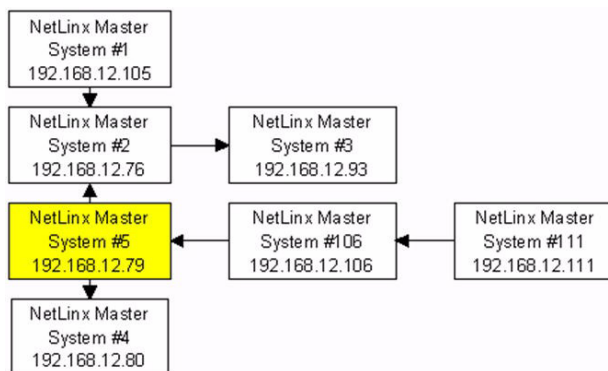

FIG. 9 Master Routing (in a system of interconnected NetLinx masters)

In FIG. 9, arrows depict the direction of the initiated connection. I.e. System #1 initiated the connection to System #2 by having the IP address of System #2 in its URL List. The following sample output is from a Telnet session connected to System #5. The connection of the NetLinx system is depicted in Illustration 2.

```

>show route
Route Data:
System Route Metric PhyAddress
-----
1 2 2 TCP Socket=18 IP=192.168.12.76 Index=3
2 2 1 TCP Socket=18 IP=192.168.12.76 Index=3
3 2 2 TCP Socket=18 IP=192.168.12.76 Index=3
4 4 1 TCP Socket=16 IP=192.168.12.80 Index=1
-> 5 5 0 Axlink
106 106 1 TCP Socket=19 IP=192.168.12.106 Index=2
111 106 2 TCP Socket=19 IP=192.168.12.106 Index=2
  
```

• Route Data:	The "Route Data:" indicates which routing mode the master is using. When the master is configured for route mode "normal", nothing additional will be presented. When the master is configured for route mode "direct", the following note will appear. "Direct Connect Only Mode"
• ->:	The "->" to the left of system number 5 indicates that system number 5 is the local system (i.e. the system that the telnet session is connected to).
• System column:	The System column lists all of the systems that are in the master's routing table.
• Route column:	The Route column indicates which system number packets are to be routed to in order to get to their destination. For example, to send a message from system #5 to system #1 the message must be sent to/through system #2. You can see this visually in FIG. 9, or by examining the Route entry for System #1 in the "show route" table.
• Metric column:	The Metric column indicates the number of system masters that the message must transverse/hop in order to get to its destination. For the example above, the metric is 2 because the message must enter system #2, then system #1. Note that a metric of 16 or "Dead" indicates a route that is expected but does not exist. Further, since the maximum usable metric is 15 there is a limit of 16 masters in the width plus height of the master topology (see the <i>Design Considerations, Constraints, and Topologies</i> section on page 163).
• PhyAddress column:	The PhyAddress column indicates the internal connection parameters used by the master to maintain the connection information. <ul style="list-style-type: none"> • "TCP Socket=" - This is the IP socket that is used for this connection. Refer to "show TCP" for additional information. • "IP=" - This is the IP address of the masters used for this connection point. • "Index=" - This is the order in which the connection was established. When the master contains the entry in its URL List this often represents the order they were entered into the list.

"Show Route" supports the "/v", verbose, parameter which will enable additional information about the routing table. This information is typically meaningful only to firmware engineering when diagnosing issues involving route table transmissions. The additional information available is described as:

• Current Time:	The number of milliseconds since boot.
• Update Time:	The milliseconds since boot when the next route table sync will occur.
• Normal Update Time:	The milliseconds since boot when the next route table sync will occur.
• Triggered Update Time:	The last time a triggered update occurred (ex. a new master came online, forcing a table update). If no triggered update has occurred, the field will say Max Time (effectively -1)
• Timeout Time:	The time that the next route table sync should have occurred by.
• Next Update:	<ul style="list-style-type: none"> • "Normal" This indicates the next update will occur at the "Normal Update Time" • "Triggered" indicates the next update is occurring due to a triggered event.
• Flags column:	The Flags column indicates if the route to that master has "changed" during the last route reporting cycle. Upon the next reporting cycle with no new change, the field will be empty.

The end result of all this routing and connection data is that a device or master can communicate with other devices or masters regardless of the physical connection of the device. Note that masters may only be "connected" to each other via Ethernet/TCP/IP. As an example (see FIG. 7 on page 160), NetLinx Studio is running on a PC that is connected to System #7 as device number 32002. The routing capabilities of the NetLinx master allow NetLinx Studio to download IR codes to the NXC-IRS4 (S=7 D=24), download a master firmware upgrade to NetLinx master #1, and download new touch panel pages to the touch panel on master #1. All of this is possible simply by having NetLinx Studio connected to a NetLinx master with M2M firmware.

Design Considerations, Constraints, and Topologies

Design Considerations

When designing a system that will utilize the M2M functionality, there are multiple points to consider. The first thing to consider is the reason for using M2M. The most common reasons are:

- Expansion of a system to add device ports.
- Expansion of a system to an area the main system cannot reach.
- Sharing of processing load.
- Standalone capability of system areas.
- Isolation of areas for security reasons.
- Dedicate a master to common/shared devices located in a central location.
- Etc... a combination of the above.

The second thing to consider is the code requirements for each master:

- Masters that are only being used to add device ports must have an empty ".tkn" file loaded, otherwise the devices will not be accessible.
- Masters that are used to share the processing load or are intended to provide standalone capability must define its local devices and the specific remote devices needed on the other masters in DEFINE_DEVICE.
- Ports on remote devices declared in DEFINE_DEVICE must exist! For example, adding touch panel port 80 when the panel file that has been loaded only specifies 20 will cause errors in the negotiation.
- Events must be written for remote devices for the program to hear them. Writing events causes the master to negotiate for the transmission of these events over M2M (as reflected in SHOW NOTIFY)

The third thing to consider is the connection topology:

- Is there a main master who all other masters must connect with?
- Do all the masters need to talk to each other?
- Or is there some combination of the above?

Constraints

To properly configure the URL Lists in a multi-master system, there must be an understanding of 3 hard constraints.

1. The first constraint is the *maximum number of 200 entries in a URL List*. This limit although important will most likely never pertain as the second constraint is far more relevant.
2. The second constraint is the *maximum number of 250 simultaneous TCP/IP connections supported by a single master*. The maximum number of simultaneous TCP/IP ICSP (NetLinx device) connections supported by a single master is 200. The top ~25 of the remaining 50 are intended to be used for internal services i.e. ftp, telnet, http, etc... The next 25 are intended to be used for IP connections used in the NetLinx code via IP_CLIENT_OPEN, IP_SERVER_OPEN, and Duet modules. If there are more than 25 IP connections made from within the code they will utilize the required number of remaining 200 IP sockets which reduces the number of available socket connections and subsequently the number of available NetLinx device connections which will reduce the number of available entries within the URL List.
3. The third constraint is the routing metric limit of 15 usable hops on the topology of the interconnected NetLinx masters. While the limit of 15 hops may seem very limiting, this is not really the case if you carefully design the topology. FIG. 10 provides a visual of the 15 hop limit:



FIG. 10 15-Hop Limit

Chain Topology

This topology shows 16 masters connected to each other such that any master is routeable to any other master.

The URL Lists would be configured like this:

System Number	
URL Entry	System Number
Master 1	Master 2
Master 2	Master 3
Master 3	Master 4
Master 4	Master 5
Master 5	Master 6
Master 6	Master 7
Master 7	Master 8
Master 8	Master 9
Master 9	Master 10
Master 10	Master 11
Master 11	Master 12
Master 12	Master 13
Master 13	Master 14
Master 14	Master 15
Master 15	Master 16
1	2
	3
	4
	5
	6
	7
	8
	9
	10
	11
	12
	13
	14
	15
	16

NOTE: The system number is being used here for readability, the actual URL/IP address must be entered into the URL List.

Using this topology can be both network and processor intensive as a message from system 1 to a device/port on system 16 must be passed between the 14 masters. For example, a serial string sent from within the code on system 1 to 5001:1:16 will be passed to system 2, and then to 3, etc. until it reaches system 16. Therefore the single serial string results in 15 messages across the network.

With an IO pulse from system 1 to a port on system 16 the following occurs; an ON message is passed to system 2, then to 3, ... until it reaches system 16, then the feedback on message sent back down the chain from system 16 to system 1, then a PUSH message from system 16 to system 1 following the same chain, then the OFF would be sent from system 1 to system 16, followed by a feedback off message from system 16 to system 1, then the RELEASE message from system 16 to system 1. Therefore that single pulse becomes 90 messages across the network. Another drawback to this topology is if a single master loses communication than all subsequent masters will cease communicating.

Star Topology

FIG. 11 shows the M2M system configured in a star topology to take advantage of the fact that each NetLinx master supports multiple connections to masters:

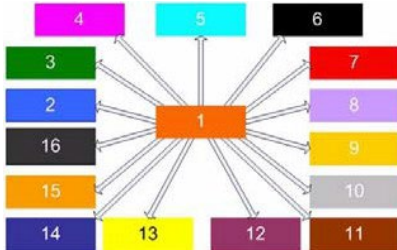

FIG. 11 Star Topology

In a *Star* topology, the URL Lists would be configured as shown below:

System Number	
URL Entry	System Number
1	Master 1
2	Master 2
3	Master 3
4	Master 4
5	Master 5
6	Master 6
7	Master 7
8	Master 8
9	Master 9
10	Master 10
11	Master 11
12	Master 12
13	Master 13
14	Master 14
15	Master 15
16	Master 16

NOTE: The system number is being used here for readability, the actual URL/IP address must be entered into the URL List.

The largest drawback to this configuration is that if there is a communication issue with master 1 all other masters lose connection with each other.

Cluster Topology

Another possible connection topology is to establish communication hubs by combining the previously discussed topologies that optimize the traffic with adjacent masters but still allow connections to all other masters, as shown in FIG. 12:

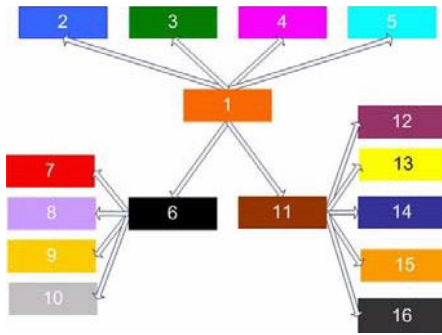

FIG. 12 Clustered Master Interconnection Topology

In a *Cluster* topology, the URL Lists would be configured as shown below:

System Number		Master 1	Master 2	Master 3	Master 4	Master 5	Master 6	Master 7	Master 8	Master 9	Master 10	Master 11	Master 12	Master 13	Master 14	Master 15	Master 16
URL Entry	1	2					7					12					
2	3						8					13					
3	4						9					14					
4	5						10					15					
5	6											16					
6	11																

NOTE: The system number is being used here for readability, the actual URL/IP address must be entered into the URL List.

When determining the interconnection topology of many NetLinx masters, special consideration should be made to have masters that communicate a lot of information with each other to connect to each other. Thus if you have two systems that share devices, control, or information they should probably be near each other in the topology and not at opposite ends of the connection matrix where each message is forced to pass through several NetLinx masters.

NOTE: Utilizing route mode direct will enable masters to isolate themselves from most traffic or to target the messages which will reduce network traffic and processor overhead.

Cascade Topology

FIG. 13 shows 16 masters connected to each other such that any master is routeable to any other master using route mode direct.

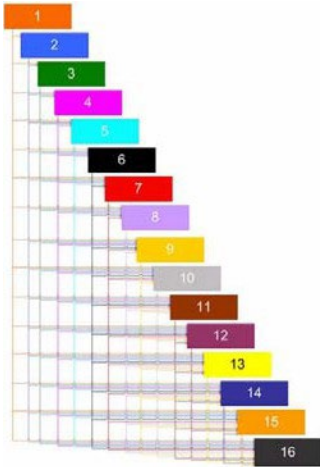

FIG. 13 Cascading Master Topology

In a *Cascade* topology, the URL Lists would be configured as shown below:

System Number																	
URL Entry	Master 1	Master 2	Master 3	Master 4	Master 5	Master 6	Master 7	Master 8	Master 9	Master 10	Master 11	Master 12	Master 13	Master 14	Master 15	Master 16	
1	2	3	4	5	6	7	8	9	10	11	12	13	14	15	16		
2	3	4	5	6	7	8	9	10	11	12	13	14	15	16			
3	4	5	6	7	8	9	10	11	12	13	14	15	16				
4	5	6	7	8	9	10	11	12	13	14	15	16					
5	6	7	8	9	10	11	12	13	14	15	16						
6	7	8	9	10	11	12	13	14	15	16							
7	8	9	10	11	12	13	14	15	16								
8	9	10	11	12	13	14	15	16									
9	10	11	12	13	14	15	16										
10	11	12	13	14	15	16											
11	12	13	14	15	16												
12	13	14	15	16													
13	14	15	16														
14	15	16															
15	16																

NOTE: The system number is being used here for readability, the actual URL/IP address must be entered into the URL List.

This topology has many advantages over the previously listed methods:

- Each master is able to see all the other masters, with one hop
- No passing of messages, which reduces the processing load on the master
- Robust, if one master goes down communication is lost with only that master and the devices connected to it
- Reduced network traffic

Cluster Topology Modified

FIG. 14 uses the Cluster concept and direct mode to link specific masters, yet remain isolated from other masters on the network.

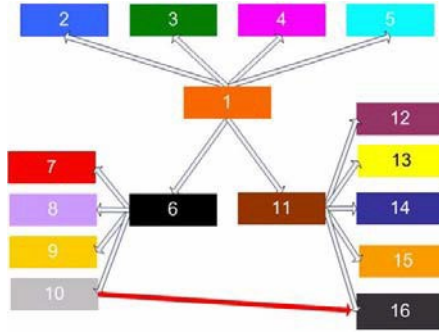

FIG. 14 Clustered master topology.

The URL Lists would be configured like this:

System Number		Master 1	Master 2	Master 3	Master 4	Master 5	Master 6	Master 7	Master 8	Master 9	Master 10	Master 11	Master 12	Master 13	Master 14	Master 15	Master 16
URL Entry	1	2				7					16	12					
2	3					8						13					
3	4					9						14					
4	5					10						15					
5	6											16					
6	11																

NOTE: The system number is being used here for readability, the actual URL/IP address must be entered into the URL List.

Although this topology looks similar to the previous Cluster topology (see FIG. 12 on page 165), by using route mode the communication connections are very specific. Masters will only be able to communicate with masters that have an arrow between them. For example:

- The master with system 1 will only be able to communicate with masters 2, 3, 4, 5, 6, and 11, but will not connect with masters 7, 8, 9, 10, 12, 13, 14, 15, and 16.
- The connection, indicated with the red arrow, between master 10 and master 16 may appear to create a routing loop, but since the masters are configured to use route mode direct a loop is avoided.
- Master 10 will only be able to connect with masters 6 and 16.

The goal when using M2M is to minimize the amount of traffic between masters while providing the required functionality. Using route mode direct with the appropriate topology helps to accomplish this goal because it is the most efficient routing method since it will reduce network traffic and master processing of messages.

Configuring and Programming M2M Systems

Using NetLinx Studio with M2M Systems

NetLinx Studio can be used to configure and diagnose M2M systems. After you have connected NetLinx Studio to the master, and you have configured the master with the proper "Network Address" information, you will need to change the system number on the master via the *Device Addressing* dialog (FIG. 15):

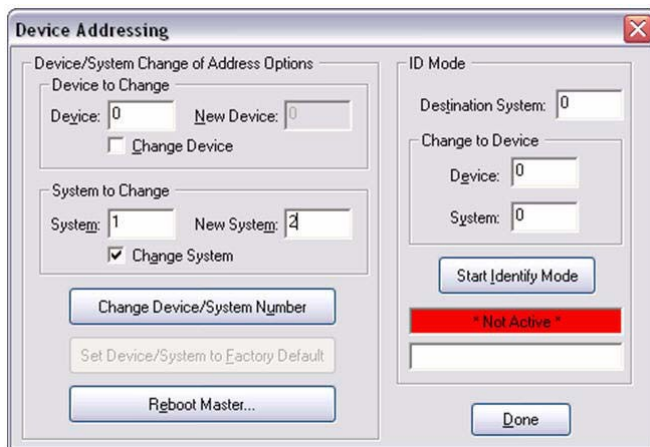

FIG. 15 NetLinx Studio - Device Addressing dialog

To access this dialog in NetLinx Studio, select **Diagnostics > Device Addressing...** (or select the *DPS* icon from the Diagnostics toolbar).

NOTE: *Once the System Number has been changed the master must be rebooted for the change to go into effect.*

The next step is to configure the URL List, via the *URL Listing* and *Add URL* dialogs (FIG. 16).

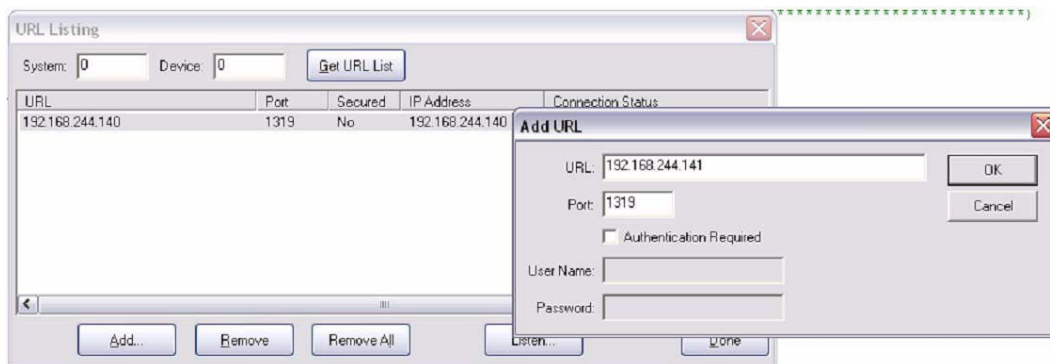

FIG. 16 NetLinx Studio - Device Addressing dialog

To access the URL Listing dialog in NetLinx Studio, select *Diagnostics > URL Listing...*, or click the *URL* icon from the Diagnostics toolbar.

- The **Get URL List** button will retrieve and display the URL List currently configured on the master which matches the "System" number specified, "0" indicates the master that NetLinx Studio used from the specified "Communication Settings". The URL List can be retrieved from other masters within the configured M2M topology. Each entry will report a "Connection Status" in the last column. The status values are "Looking up IP, Attempting Connection, and Connected"
- The **Add** button will launch the *Add URL* dialog to add a new URL to the list using the appropriate authentication credentials, if required.
- The **Remove** button will remove the currently selected entry from the URL List.
- The **Remove All** button will remove all the entries from the URL List.
- The **Listen** button will launch a window that will allow NetLinx Studio to listen for NetLinx masters on the local subnet using the port specified, default port **1319**. From this view the options are to close the window or add the selected NetLinx master and its associated IP information to the *Add URL* dialog.

The masters and devices in a M2M system can be viewed using the **Refresh Network Online Tree** option within the Online Tree (click the **Display** button in the Online Tree tab of the Workspace Bar to access the Online Tree menu). This function will run a recursive process that will connect to the master specified in the *Communication Settings* dialog, and gather information to populate the Online Tree. If there are any other masters in the routing table, NetLinx Studio will then connect to those masters and get their information until the end of each branch is reached. There are some limitations in diagnosing or watching devices/ports in a M2M system using NetLinx Studio. For example, if NetLinx Studio is connected to master system 1, and a connection is established to master system 2, then only the devices on system 2 defined within the code of system 1 will be accessible to watch via "Asynchronous Notifications".

Using Telnet with M2M Systems

Once the master's system number has been configured via NetLinx Studio, a telnet session can be used to configure and diagnose M2M systems. Note, when troubleshooting M2M systems NetLinx Studio and telnet connections to the master complement each other as the information from one application/interface may not be available from the other. The first command to become familiar with is to set the routing mode on the master. The command is "route mode" followed by the desired mode, direct or normal. The routing mode on the master can be verified by sending the command "route mode" with no parameter, or with the command "show route". The "show route" command is described in a previous section of this document.

To view the entries in the URL List use the command "show url". To modify the entries in the URL List use the command "set url". Both of these commands will accept a <D:P:S> parameter to view or modify URL Lists on other masters.

The command "show system" will display all the systems and devices that are online and tracked in the device manager. The device manager tracks all devices defined in DEFINE_DEVICE or used in DEFINE_EVENT. The "show system" command supports two mutually exclusive parameters. The "<S>" parameter displays the devices on the specified system. For example, when connected to system 1 issue the command "show system 2" to display the devices on System 2. Using the "/min" parameter will limit the display to a minimal set of information.

There are two commands that are similar yet remain unique, they are "show remote" and "show notify".

- "show remote" displays the devices on a remote master that are being monitored by the local master.
- "show notify" displays the devices on the local master that are being monitored by a remote master.

The outputs of both commands are structured similarly and are described below. In the example below, "show remote" was issued on system 1. "show notify" was issued on system 16:

```
>show remote
Show Remote Device List
-----
Device List of Remote Devices requested by this System
Device Port System Needs
-----
05001 00001 00016 Channels Commands Strings
05001 00005 00016 Channels Commands
33001 00001 00016 Channels Commands Strings Levels
>show notify
Show Notification List
-----
Device Notification List of devices requested by other Systems
Device:Port System Needs
-----
05001:00001 00001 Channels Commands Strings
05001:00005 00001 Channels Commands
33001:00001 00001 Channels Commands Strings Levels
```

• Device column:	The Device column lists the device that is being monitored.
• Port column:	The Port column lists the port on the device that is being monitored
• System column:	The System calling lists the system number that the device is connected to in the case of the "show remote". With "show notify" the system number that is watching the device will be listed.
• Needs column:	The Needs column contains the information that is being tracked. A device defined in "DEFINE_DEVICE" or used in "DEFINE_EVENT" will list the default needs "Channels Commands". The "Strings" need will be listed if the device is used in a "DATA_EVENT" or "CREATE_BUFFER". The "Levels" need will be listed if the device is used in a "LEVEL_EVENT" or "CREATE_LEVEL".

The command to view all of the TCP connections on a master is "show tcp". This command supports two parameters:

- The first parameter is "/v" which stands for verbose, this does not appear to change the results.
- The second parameter is "/all", this will display information about all 200 TCP/IP locations.

Control/NetLinx Language Support

The features of control to M2M include channel control (PUSH/RELEASE/ON/OFF/TO), level control, send commands and send strings. Channel controls allow one NetLinx master to PUSH/RELEASE a channel on a device of another system via the DO_PUSH/DO_RELEASE functions. Additionally, ON, OFF, TO, and feedback statements can control channels on devices of remote systems. If a channel has a characteristic modifier associated with it, that modifier still applies to the channel regardless of whether the channel is manipulated locally or remotely. For example, if a group of channels and variables is mutually exclusive then an ON to one of the channels will turn off all other channels and variables in the group prior to turning on the desired channel. Levels, strings and commands are essentially forwarded to the destination device. Note that control is not limited to physical devices and that NetLinx program defined virtual devices may also be manipulated by a remote system. This allows a local system to define a virtual device that can receive PUSH, RELEASE, ON, OFF, etc. and make programmatic decisions based upon that control. Additionally, notification of control messages is not limited to "main line" functions like PUSH and RELEASE; rather all EVENT based code will operate normally regardless of the source of the original control message/function.

Design Consideration and Constraints

In order to reference devices of other NetLinx systems, the devices *MUST* be defined in the `DEFINE_DEVICE` section of the NetLinx program. Conversely, only devices that are necessary should be placed in the `DEFINE_DEVICE` section to avoid any unnecessary network traffic between NetLinx masters.

- **DEFINE_LATCHING** – A remote device’s channel is not allowed in the `DEFINE_LATCHING` section.
- **DEFINE_MUTUALLY_EXCLUSIVE** – A remote device’s channel is not allowed in the `DEFINE_MUTUALLY_EXCLUSIVE` section.
- **DEFINE_TOGGING** – A remote device’s channel is not allowed in the `DEFINE_TOGGING` section.
- The proper way to modify a channel’s behavior is to use **ON/OFF/TO/PULSE!**
- **DEFINE_MODULE** – As a guideline the best practice is to run a UI module on the master that the touch panel or keypad is connected to, and to run the `COMM` module on the master that the device is connected to. This practice should limit the number of messages across the network as the amount of messages between the UI and `COMM` modules is generally smaller than the amount of messages between the device and the `COMM` module.

Inter-Master Variables

Inter-master variables are not implemented at this time. However the value of variables may be passed among the masters in the system using `SEND_COMMAND` or `SEND_STRING` to a common virtual device.

Using Virtual Devices as Moderators

Virtual Devices may be used as moderators to share information between masters that may or may not be related to specific devices, like passing the values of a variable. They can also be used to minimize the network traffic by using them to distribute the information to multiple devices on other masters.

Code Example: Tracking Online/Offline State In a Remote Master

```
DEFINE_DEVICE
SYSTEM4 = 33001:1:4
DEFINE_VARIABLE
INTEGER SYSTEM4_STATUS
DEFINE_EVENT
DATA_EVENT[SYSTEM4]
{
  ONLINE:
  {
    SYSTEM4_STATUS = 1
  }

  OFFLINE:
  {
    SYSTEM4_STATUS = 0
  }
}
```

Modifying the URL List From Within the NetLinx Code

There may be times when viewing or changing the URL List from within the NetLinx code is desired. This can be accomplished using the following functions “`GET_URL_LIST`”, “`ADD_URL_ENTRY`”, and “`DELETE_URL_ENTRY`”. Please refer to the NetLinx Keywords Help within NetLinx Studio for details and examples.

M2M Processing Queues and Troubleshooting

The Route Manager queue is the message queue that receives any inbound route table messages from other masters. These messages are then processed by the Route Manager firmware to update its tables, refer to the section above labeled “Master Routing”.

The Notification Manager queue is the message queue that receives notification requests for device state changes from a remote entity (ex. another master). In M2M communication, two connected masters do not blindly forward all local device state changes to the other master. Instead, they will only forward specifically requested state changes based on the remote master’s needs as defined in the NetLinx code, refer to the telnet commands “`show remote`” and “`show notify`”. The Notification manager queue receives these messages and then the Notification manager processes the requests and adds the information to its database, refer to the telnet commands “`show remote`” and “`show notify`”, of “requested” state changes. When a state change occurs in the master, it compares the change to its database and if a remote master has requested notification of the change, it forwards the state change to the remote master.

When configuring M2M systems it may be necessary to alter the queue sizes of the above mentioned queues. This can be done using the following telnet commands “`show buffers`”, “`show max buffers`”, and “`set queue size`”. To view the number of messages in each queue at a specific moment use the command “`show buffers`”. To monitor the largest number of messages in each queue since the master has booted use the command “`show max buffers`”. Use the command “`set queue size`” to determine and set the upper limit on each queue. If the information returned from “`show max buffers`” is equal to the upper limit of the queue, it would be appropriate to increase the upper limit of the queue size.

General M2M Issues

When multiple masters exist within a large NetLinx installation the significance of the System number component cannot be over emphasized. Out of habit it is easy to ignore the system field within NetLinx Studio because its value has not meant anything in standalone systems. A significant source of technical support phone calls will be directly related to invalid or unintentionally incorrect settings of the system number, URL List, or route mode. When NetLinx Studio connects to a single master, yet allows the user to access all other system masters it is inevitable that some confusion will occur. Therefore, it is a good idea to document each master’s system number and the topology of the interconnections!

Appendix C - Marshalling Protocol

Overview

The protocol assumes that every logical field (group of bytes) is prefixed with type/size information. For example, if there is a 4 byte long integer field within a structure, the byte stream representing that field consists of 5 bytes. The first byte (0xE3) specifies that a long integer follows and then the 4 remaining bytes contain the value of the long integer.

This concept is extended to all primitive, structure and array types. The type of a field is always stored as a single byte. The size of a field may or may not be stored depending upon the field type (fields with know lengths do not have a size prefix).

The specific formats of all the supported types are described in the table below.

Marshaled Stream Format

The following table describes the byte format of the various types supported in the marshaller (fields within <>'s indicate actual data bytes):

Byte Formats Supported in the Marshaller		
Type	Description	Stream Format
BYTE	Unsigned char/byte value.	0xE1 <BYTE>
WORD	Unsigned short value.	0xE2 <WORD Hi> <WORD Lo>
DWORD	4-byte value (could be an unsigned long integer or a float).	0xE3 <DWORD MSB> . . <DWORD LSB>
QWORD	8-byte value (could be an unsigned Quad-word or a double).	0xE4 <QWORD MSB> <QWORD LSB>
BYTESTR	Sequence of BYTE's whose element count is <= 64K.	0xE5 Length Hi Length Lo <BYTE Sequence> . .
WORDSTR	Sequence of WORD's whose element count is <= 64K.	0xE6 Length Hi Length Lo <WORD Sequence> . .
DWORDSTR	Sequence of DWORD's whose element count is <= 64K.	0xE7 Length Hi Length Lo <DWORD Sequence> . .
QWORDSTR	Sequence of QWORD's whose element count is <= 64K.	0xE8 Length Hi Length Lo <QWORD Sequence> . .
LBYTESTR	Large sequence of BYTE's whose element count can be > 64K (larger version of BYTESTR).	0xE9 Length MSB . . Length LSB < BYTE Sequence> . .

Byte Formats Supported in the Marshaller (Cont.)		
STRUCT	A structure containing one or more fields. Each element within a structure is self-descriptive and can be any of the types in this table.	0xEA <First Struct Element 1> . .
ENDSTRUCT	Byte indicator for end of structure - not really a data type prefix.	0xEB
ARRAY	Array of any one of the types in this table whose elementcount can be > 64K. Each element in an array is self descriptive. The type of the first element (byte after LengthLSB) is the type of the entire array.	0xEC Length MSB . . Length LSB <Array Element 1> . .
SKIP	Byte indicator for space to be skipped in the input and NULL'ed in the marshaled output. This can be viewed as a NULL data type prefix.	0xED

Marshalling Protocol (Variables)

The protocol assumes that every logical field (variable) is identified with a name or index, type/size information and the actual data. For example, if there is a 4 byte long integer field within a structure, the XML stream representing that field would consist of 3 tags:

- A name tag specifying the name of the variable
- a type tag specifying a 4 byte unsigned value
- the data.

This concept is extended to all primitive, structure and array types. The type of a field is always stored using W3C standard type declarations. The type of the field is optional, as the data will be "stuffed" into whatever type matches the name of the parameter. The specific formats of all the supported types are described below.

Marshaled Stream Format

The following table describes the byte format of the various types supported in the XML marshaller.

Types Supported in the XML Marshaller		
Type	Description	Stream Format
BYTE	Unsigned char/byte value. If var is an element of an array, name is replaced with <index></index>. The index value, and the type are optional. Typically, only <var><data>Data</data></var> is needed.	<var> <name>MyName</name> <type>ui1</type> <data>255</data> </var>
UWORD	Unsigned short value. If var is an element of an array, name is replaced with <index></index>. The index value, and the type are optional. Typically, only <var><data>Data</data></var> is needed.	<var> <name>MyName</name> <type>ui2</type> <data>65535</data> </var>
WORD	Signed short value. If var is an element of an array, name is replaced with <index></index>. The index value, and the type are optional. Typically, only <var><data>Data</data></var> is needed.	<var> <name>MyName</name> <type>i2</type> <data>-32767</data> </var>
ULONG	4-byte unsigned value. If var is an element of an array, name is replaced with <index></index>. The index value, and the type are optional. Typically, only <var><data>Data</data></var> is needed.	<var> <name>MyName</name> <type>ui4</type> <data>4294967295 </data> </var>
LONG	4-byte signed value. If var is an element of an array, name is replaced with <index></index>. The index value, and the type are optional. Typically, only <var><data>Data</data></var> is needed.	<var> <name>MyName</name> <type>ui4</type> <data>-2147483647 </data> </var>
FLOAT	4-byte IEEE 754 float value. If var is an element of an array, name is replaced with <index></index>. The index value, and the type are optional. Typically, only <var><data>Data</data></var> is needed.	<var> <name>MyName</name> <type>float.IEEE.754.32</type> <data>1.23</data> </var>
DOUBLE	8-byte IEEE 754 float value. If var is an element of an array, name is replaced with <index></index>. The index value, and the type are optional. Typically, only <var><data>Data</data></var> is needed.	<var> <name>MyName</name> <type>float.IEEE.754.64</type> <data>4.56</data> </var>

Types Supported in the XML Marshaller (Cont.)		
STRUCT	A structure containing one or more fields. Each element within a structure is self-descriptive and can be any of the types in this table. If the struct is the outermost parent, then name is optional. If struct is an element of an array, name is replaced with <index></index> and the index value.	<pre><struct> <name><MyName></name> <var>... </var> </struct></pre>
ARRAY	Array of any one of the types in this table. Each element in an array is self-descriptive. The type of the parent is the type of the entire array. Type is optional and generally not included when the array is an array of structures. Current Length is optional. Array can contain a series of items, a series of structures or a series of array. Elements of an array should define an index instead of a name. This is the commonly used format for structures but all types are allowed.	<pre><array> <name><MyName></name> <type>Type</type> <curLength>100</curLength> <var> <index>1</index>... </var></array> ...or... <array> <name><MyName></name> <type>Type</type> <curLength>100</curLength> <struct> <index>1</index>... </struct> </array> ... or ... <array> <name><MyName></name> <type>Type</type> <curLength>100</curLength> <array> <index>1</index>... </array> </array></pre>
Array - String encoding (Strings)	Array of unsigned characters. Data is encoded using String encoding. Type and length are optional.	<pre><array> <name><MyName></name> <type>Type</type> <curLength>100</curLength> <string>MyString</string> </array></pre>
ARRAY - Binary Encoded	Array of any one of the types in this table except structures. This is the default for all non-CHAR arrays but CHAR arrays can use this encoding as well. The type of the parent is the type of the entire array. Type is optional and generally not included. Current Length is optional. Style is LE for little endian or BE for big endian. BE is the default. Size indicates the byte size but not the type. ByteSize=4 is used for LONG, SLONG, and FLOAT and means that 8 nibbles will be present for each element being encoded/decoded.	<pre><array> <name><MyName></name> <type>Type</type> <curLength>100</curLength> <encoded> <style>LE or BE</ style > <size>1,2,4,8</size> <data>01020304</data> </encoded> </array></pre>

Encoding Notes

- The encoding XML will not contain any white space. This includes CR,LF pairs.
- The decoding XML may contain white spaces. They will be ignored according to standard XML rules (i.e. Spaces as between tags are read.)
- Array may be encoded or decoded as binary encoded data
- XML comments, <! ---- >, will be ignored in decode.

String Encoding

NetLinx has no native string type, but since it is a common type the encoding/decoding of the string data will be logically handled so the XML remains concise. CHAR arrays will be encoded/decoded as a string type, printable ASCII characters appear as ASCII, and non-printable characters appear as escaped decimal or hex code, **&#<decimal code>**; or **&#x<hex code>**; An example string would be:

```
<data>My Name is Jimmy Buffet&#x0D;</data>
```

- or -

```
<data>My Name is Jimmy Buffet &#13;</data>
```

Additionally, some characters have a more readable syntax. These characters are invalid in XML; so, the following characters can be encoded in the above format or the following format:

Character	Escape Version
<	<
>	>
&	&
'	'
"	"

Binary Array Encoding

Arrays can optionally be encoded/decoded as pairs of ASCII-encoded HEX. The pairs of ASCII-encoded HEX needs to be padded to the size of the data so a 4-byte data value needs to have 4 bytes that represent it. There are no spaces between pairs, and the default is Big-Endian. Little Endian can be encoded or decoded as an option. The HEX letters may appear as upper or lower case and are by default upper case. Any example of a 2-byte (signed or unsigned) array containing the value 1,2,3,4,1,12,13,14 is:

```
<encoded>
  <style>BE</ style >
  <size>2</size>
  <data>010203040B0C0D0E</data>
</encoded>
```

This is the default type of encoding for non-CHAR arrays but can be used to encode/decode char arrays as well. The data section must contain BytesSize*Elements nibbles.

Binary Encoding Result

Binary Encoding Result	
Byte In Encoded String	Description
\$EC	Start of Array Encoding
\$00 \$00 \$00 \$03	Number of Elements in the Array
\$EA	Start of Structure
\$E3	DWORD: LONG or SLONG
\$00 \$A9 \$63 \$48	Data: 11101000
\$E5	Start of CHAR Array (String)
\$00 \$0D	Length of Array: 13
\$42 \$75 \$66 \$66 \$65 \$74 \$2C \$20 \$4A \$69 \$6D \$6D \$79	Data: 'Buffet, Jimmy'
\$E5	Start of CHAR Array (String)
\$00 \$1A	Length of Array: 26
\$4C \$69 \$76 \$69 \$6E \$67 \$20 \$26 \$20 \$44 \$79 \$69 \$6E \$67 \$20 \$69 \$6E \$20 \$33 \$2F \$34 \$20 \$54 \$69 \$6D \$65	Data: 'Living & Dying in 3/4 Time'
\$E5	Start of CHAR Array (String)
\$00 \$03	Length of Array: 3
\$4D \$43 \$41	Data: 'MCA'
\$E5	Start of CHAR Array (String)
\$00 \$03	Length of Array: 3
\$4D \$43 \$41	Data: 'MCA'
\$E5	Start of CHAR Array (String)
\$00 \$04	Length of Array: 4
\$31 \$39 \$37 \$34	Data: '1974'
\$E2	WORD: INTEGER or SINTEGER
\$00 \$0B	Data: 11
\$E5	Start of CHAR Array (String)
\$00 \$0A	Length of Array: 10
\$33 \$31 \$33 \$32 \$33 \$33 \$33 \$34 \$33 \$35	Data: '3132333435'
\$E2	WORD: INTEGER or SINTEGER
\$00 \$5B	Data: 91
\$EB	End of Structure
\$EA	Start of Structure
\$E3	DWORD: LONG or SLONG
\$01 \$07 \$2F \$E5	Data: 17248229

\$E5	Start of CHAR Array (String)
Binary Encoding Result (Cont.)	
Byte In Encoded String	Description
\$00 \$0D	Length of Array: 13
\$42 \$75 \$66 \$66 \$65 \$74 \$2C \$20 \$4A \$69 \$6D \$6D \$79	Data: 'Buffet, Jimmy'
\$E5	Start of CHAR Array (String)
\$00 \$15	Length of Array: 21
\$4F \$66 \$66 \$20 \$74 \$6F \$20 \$53 \$65 \$65 \$20 \$74 \$68 \$65 \$20 \$4C \$69 \$7A \$61 \$72 \$64	Data: 'Off to See the Lizard'
\$E5	Start of CHAR Array (String)
\$00 \$03	Length of Array: 3
\$4D \$43 \$41	Data: 'MCA'
\$E5	Start of CHAR Array (String)
\$00 \$03	Length of Array: 3
\$4D \$43 \$41	Data: 'MCA'
\$E5	Start of CHAR Array (String)
\$00 \$04	Length of Array: 4
\$31 \$39 \$38 \$39	Data: '1989'
\$E2	WORD: INTEGER or SINTEGER
\$00 \$0B	Data: 11
\$E5	Start of CHAR Array (String)
\$00 \$0A	Length of Array: 10
\$33 \$31 \$33 \$32 \$33 \$33 \$33 \$34 \$33 \$36	Data: '3132333436'
\$E2	WORD: INTEGER or SINTEGER
\$00 \$69	Data: 105
\$EB	End of Structure
\$EA	Start of Structure
\$E3	DWORD: LONG or SLONG
\$00 \$BC \$1E \$A4	Data: 12328612
\$E5	Start of CHAR Array (String)
\$00 \$0D	Length of Array: 13
\$42 \$75 \$66 \$66 \$65 \$74 \$2C \$20 \$4A \$69 \$6D \$6D \$79	Data: 'Buffet, Jimmy'
\$E5	Start of CHAR Array (String)
\$00 \$05	Length of Array: 5
\$41 \$2D \$31 \$2D \$41	Data: 'A-1-A'
\$E5	Start of CHAR Array (String)
\$00 \$03	Length of Array: 3
\$4D \$43 \$41	Data: 'MCA'
\$E5	Start of CHAR Array (String)
\$00 \$03	Length of Array: 3
\$4D \$43 \$41	Data: 'MCA'
\$E5	Start of CHAR Array (String)
\$00 \$04	Length of Array: 4
\$31 \$39 \$37 \$34	Data: '1974'
\$E2	WORD: INTEGER or SINTEGER
\$00 \$0B	Data: 11
\$E5	Start of CHAR Array (String)
\$00 \$0A	Length of Array: 10
\$33 \$31 \$33 \$32 \$33 \$33 \$33 \$34 \$33 \$37	Data: '3132333437'
\$E2	WORD: INTEGER or SINTEGER
\$00 \$BD	Data: 189
\$EB	End of Structure

XML Encoding Result

```

<array>
  <curLength>0</curLength>
  <STRUCT>
    <index>1</index>
    <var>
      <name>LTITLEID</name>
      <data>11101000</data>
    </var>
    <array>
      <name>SARTIST</name>
      <curLength>13</curLength>
      <string>Buffet, Jimmy</string>
    </array>
    <array>
      <name>STITLE</name>
      <curLength>26</curLength>
      <string>Living &amp; Dying in 3/4 Time</string>
    </array>
    <array>
      <name>SCOPYRIGHT</name>
      <curLength>3</curLength>
      <string>MCA</string>
    </array>
    <array>
      <name>SLABEL</name>
      <curLength>3</curLength>
      <string>MCA</string>
    </array>
    <array>
      <name>SRELEASEDATE</name>
      <curLength>4</curLength>
      <string>1974</string>
    </array>
    <var>
      <name>NNUMTRACKS</name>
      <data>11</data>
    </var>
    <array>
      <name>SCODE</name>
      <curLength>10</curLength>
      <string>3132333435</string>
    </array>
    <var>
      <name>NDISCNUMBER</name>
      <data>91</data>
    </var>
  </STRUCT>
  <struct>
    <index>2</index>
    <var>
      <name>LTITLEID</name>
      <data>17248229</data>
    </var>
    ...
    <var>
      <name>NDISCNUMBER</name>
      <data>105</data>
    </var>
  </STRUCT>
  <STRUCT>
    <index>3</index>
    <var>
      <name>LTITLEID</name>
      <data>12328612</data>
    </var>
    ...
    <var>
      <name>NDISCNUMBER</name>
      <data>189</data>
    </var>
  </STRUCT>
</array>

```

Appendix D - NetLinx vs. Access

Overview

The NetLinx control system was designed to upgrade the processor bus and improve the power of the Access programming language. Originally named Access2, the NetLinx was designed to be a superset of the Access programming language. The relationship between the new language (NetLinx) and Access is very similar to the relationship between C++ and C. Just as C++ brought a whole new level of power to C programming, NetLinx offers a variety of new tools and commands to dynamically increase the speed and power of present and future applications. NetLinx contains all of the elements of Access. Largely, you can use the same code from Access systems in NetLinx systems. Some exceptions include variable names conflicting with new NetLinx keywords; however, Access keywords are valid in NetLinx. You cannot compile NetLinx code on an Access compiler, or download NetLinx code to an Access control system. To upgrade an existing Access control system to NetLinx you must upgrade the Access Master to a NetLinx Master. You can still use the existing Access equipment as long as you can disable the existing Access Central Controller.

NOTE: The exceptions are the Axcent, the Axcent2, the AXB-EM232, and the AXB-MPE+ Master Port Expander. None of these integrated controllers allow you to disable the Central Controller. Both Access Card Frame Systems and Axcent3 systems allow you to either remove or disable the Access Central Controller.

NOTE: If you are using an Axcent3 / Axcent3 Pro, you can disable the Master with the Open Access program. You can connect the Axcent3 / Axcent3 Pro to a NetLinx Master Module via AxLink. Then you can compile and download the existing Access code.

Several Access control limitations have been fixed in NetLinx.

- NetLinx expands the types of data and variables from Access.
- NetLinx provides multiple processes and event threads beyond the Mainline in Access.
- NetLinx offers more options in distributed processing. NetLinx expands and strengthens Master-to-Master communications and expands the traditional AxLink bus to include ICSNet and Ethernet Network communications.

Access is linear in its process. At run time, Access runs the DEFINE_START code once when the system is loaded or restarted. Access then makes a pass through mainline code, polls the bus for activity, checks the wait and pulse stacks, and repeats the process again. The length of mainline and the activity on the bus affect runtime speeds. The mainline process is considered a single thread. NetLinx runs on multiple threads; mainline and event handlers run on parallel threads. Event handlers are defined within NetLinx and operate like mini-mainlines. They contain far less code and run faster than mainline. If an event occurs, and an event handler has been defined for that event, NetLinx bypasses mainline and runs the event handler.

NetLinx vs. Access - Comparison by Structure

DEFINE_DEVICE

Access Language	NetLinx Language
<p>Access defines devices with a single number (sometimes called an address) from 1 to 255. Access permits a maximum of 255 devices on the AxLink bus.</p> <pre> DEFINE_DEVICE VCR = 1 (* AXC-IRS *) VPROJ= 2 (* AXC-IRS *) TP = 128 (* AXT-CA10*) </pre>	<p>NetLinx defines the device by Device:Port:System.</p> <ul style="list-style-type: none"> • Device is a 16-bit integer representing the device number. Physical devices range from 1 to 32,000. Virtual devices range from 32,768 to 36,863. <p>NOTE: These numbers do not seem so random when represented in hexadecimal. Physical devices range from \$0001 to \$7FFF. Virtual devices range from \$8000 to \$8FFF.</p> <ul style="list-style-type: none"> • Port is a 16-bit integer representing the port number in a range of 1 through the number of ports on the device (1 = this port) • System is a 16-bit integer representing the system number (0 = this system). <pre> DEFINE_DEVICE VCR = 1:1:0 (* NXC-IRS4 PORT 1 *) VPROJ= 1:2:0 (* PORT 2 *) TP = 128:1:0 (* AXT-CA10 *) </pre>

DEFINE_CONSTANT

Access Language	NetLinx Language
<p>Access defines constants as either a fixed integer value between 0 and 65,535 or an array with a maximum length of 255 bytes in which each element can hold a value from 0 to 255. These values can be expressed in ASCII, Decimal, or Hexadecimal.</p> <pre> DEFINE_CONSTANT VALUE_MAX = 140 DEFAULT_NAME = 'Access' ETX = "\$FE,\$FF" VALUE_MAX = VALUE_MIN + 100 </pre>	<p>NetLinx processes constants just like Access. NetLinx also allows you to define an expression in the DEFINE_CONSTANT section. The expression cannot contain any variables.</p> <pre> DEFINE_CONSTANT VALUE_MIN = 40 DEFAULT_NAME = 'Access' ETX [] = {\$FE,\$FF} VALUE_MAX = VALUE_MIN + 100 </pre>

DEFINE_VARIABLES

Access Language	NetLinx Language
<p>Access supports 5 types of variables:</p> <ul style="list-style-type: none"> • Integer Variables (default) can contain a value from 0 to 65,535. • Character Arrays are single element arrays, in which each element has a value from 0 to 255 with a maximum of 255 elements • 2-Dimensional Arrays equate to a maximum of 255 single element character arrays. Each element can have a value from 0 to 255. • Integer Arrays are single element arrays, in which each element can contain a value from 0 to 65,535 with a maximum of 255 elements • 2-Dimensional Integer Arrays may have a maximum value of 65,535. <p>Variables are Non-Volatile (the variable loses its value when the program is loaded, but retains its value if the controller is reset).</p> <pre>DEFINE_VARIABLE VALUE ARRAY[3] ARRAY_2DIM[4][6] INTEGER INT_ARRAY[6]</pre>	<p>NetLinx substantially increased the number of supported variable types. In addition to more data types, NetLinx also supports Sets, Structures, and Multi-dimensional arrays.</p> <p>Arrays default to Character Arrays. Variables default to Integer Variables. Variables default to Non-Volatile, but can be set as Non-Volatile or Volatile (Volatile variables are initialized when code is loaded or when the system is reset).</p> <pre>DEFINE_VARIABLE CHAR VALUE1 WIDECHAR BIGCHAR INTEGER VALUE2 SINTEGER SIGNED1 LONG BIGVALUE SLONG SIGNED2 FLOAT DECIMAL DOUBLE VERYBIGVALUE INTEGER ARRAY[3][3][3] VOLATILE INTEGER RESET_VAR</pre>

DEFINE_CALL (Subroutines)

Access Language	NetLinx Language
<p>Access provides two methods for incorporating subroutines into your program.</p> <ul style="list-style-type: none"> • DEFINE_CALL subroutines are defined in the program and support parameter passing into the call. Changing the parameter value inside the call changes the value of the variable passed to the parameter. The DEFINE_CALL can use global variables or defined local variables. DEFINE_CALL is for standalone statements and cannot be used in-line as an expression. • SYSTEM_CALL is an externally defined subroutine with a '.LIB' extension. SYSTEM_CALL programs are produced by AMX and are available on CD-ROM and on the Tech Support Web site at www.amx.com. <pre>DEFINE_CALL 'SWITCH' (CARD,IN,OUT) { SEND_STRING CARD, "ITOA(IN),'*',ITOA(OUT),'!' " } DEFINE_CALL 'MULTIPLY' (X,Y,RESULT) { RESULT = X * Y } DEFINE_PROGRAM PUSH[TP,11] { CALL 'SWITCH' (SWITCHER,4,1) } PUSH[TP,12] { CALL 'MULTIPLY' (3,4,VALUE) } SYSTEM_CALL [1] 'VCR1' (VCR,TP,21,22,23,24,25,26,27,28,0)</pre>	<p>Like Access, NetLinx supports DEFINE_CALL and SYSTEM_CALL. NetLinx also supports functions, which are similar to a DEFINE_CALL(s). They can be used standalone or in-line as an expression. Functions are defined in the DEFINE_CALL section of the code as a global function.</p> <p>Defining a function differs slightly from a DEFINE_CALL:</p> <ul style="list-style-type: none"> • The data type of the function's return value must be specified. • The function name is not enclosed with quotes or case sensitive. <pre>DEFINE_CALL 'SWITCH' (CARD,IN,OUT) { SEND_STRING CARD, "ITOA(IN),'*',ITOA(OUT),'!' " } DEFINE_FUNCTION INTEGER MULTIPLY (INTEGER X, INTEGER Y) { RETURN (X * Y) } DEFINE_PROGRAM PUSH[TP,11] { CALL 'SWITCH' (SWITCHER,4,1) } PUSH[TP,12] { VALUE = MULTIPLY(3, 4) } SYSTEM_CALL [1] 'VCR1' (VCR,TP,21,22,23,24,25,26,27,28,0)</pre>

DEFINE_START

Access Language	NetLinx Language
<p>DEFINE_START sets the initialization parameters for the Access program. This section defines buffers, levels, sets communication settings, and initializes variables. DEFINE_START is run once when the program is loaded or the system is reset.</p> <pre>DEFINE_START CREATE_BUFFER TP, TP_BUFFER CREATE_LEVEL VOL, 1, VOL_LEVEL1 SEND_COMMAND SWT, 'SET BAUD 9600,N,8,1,DISABLE' ON[CLEAR_TO_SEND]</pre>	<p>There is no difference between the way Access and NetLinx handle the DEFINE_START section of the program; however, the role of the DEFINE_START section is greatly reduced. Variable initializations are handled in the DEFINE_VARIABLE section. Device initializations are handled with a DATA_EVENT in the DEFINE_EVENT section.</p> <pre>DEFINE_START ON[CLEAR_TO_SEND]</pre>

DEFINE_EVENT

Access Language	NetLinx Language
<p>Access does not support events.</p>	<p>Events are a new process in NetLinx. The events thread runs parallel to the mainline thread. Events describe certain types of conditions within the control system. If the conditions are defined as a DEFINE_EVENT, the event code is run and mainline is bypassed.</p> <p>There are five different types of events: Button Events, Channel Events, Data Events, Level Events, and Timeline Events.</p> <pre data-bbox="899 380 1154 705"> DEFINE_EVENT BUTTON_EVENT[TP,21] (* KC REPEAT 'A' *) { PUSH: {SEND_STRING KC, 'A' } RELEASE: { } HOLD[5,REPEAT]: { SEND_STRING KC, 'A' } } </pre>

DEFINE_PROGRAM

Access Language	NetLinx Language
<p>The DEFINE_PROGRAM or mainline section of the Access program is where most of the programming process takes place. Access supports 99 reserved identifiers or keywords. 83 of these keywords can be used in the mainline.</p> <p>Access runs through a loop where:</p> <ul data-bbox="293 951 829 1079" style="list-style-type: none"> • The AxLink bus is queried for any changes. • Mainline code is run. • Access checks the wait stack and the pulse stacks for any expired waits and pulses. • The process is repeated. 	<p>The DEFINE_PROGRAM or mainline section of the NetLinx program and the DEFINE_EVENT section of code are responsible for processing events in a NetLinx system. NetLinx has expanded the list of keywords to 194 reserved identifiers. NetLinx also supports loops, data conversions, string processing, and file handling.</p> <p>NetLinx handles mainline in a similar fashion to Access, with a couple of differences. Because NetLinx supports multiple bus formats (AxLink, ICSNet, and Ethernet), events and changes in bus status are handled through a connection manager and message queue.</p> <p>NetLinx checks the message queue to see if an event is defined for the message. If not, NetLinx makes a pass through mainline.</p> <p>When NetLinx finishes the event handler or mainline, NetLinx processes the Wait list and Pulse list, and returns to the message queue to start the process again.</p>

Access/NetLinX Incompatibility

According to previous versions of each of their language reference manuals, Access and NetLinX each give the operator NOT highest precedence while giving AND and OR lowest. As demonstrated in the following code, however, the two systems behave differently. In reality, Access gives the operator NOT lowest precedence.

```
DEFINE_VARIABLE
C D E
DEFINE_CALL 'GO' (A,B)
{
  C = !A && B
  D = B && !A
  E = !B && !A
}
DEFINE_PROGRAM
PUSH[1,1]
CALL 'GO' (0,0)

PUSH[1,2]
CALL 'GO' (1,0)
PUSH[1,3]
CALL 'GO' (0,1)
PUSH[1,4]
CALL 'GO' (1,1)
```

Access RESULTS				
A	B	!A && B	B && !A	!B && !A
0	0	1	0	1
1	0	1	0	1
0	1	1	1	0
1	1	0	0	1

NETLINX RESULTS				
A	B	!A && B	B && !A	!B && !A
0	0	0	0	1
1	0	0	0	0
0	1	1	1	0
1	1	0	0	0

The problem applies whether A and B are channels, variables, or expressions, and for OR as well as AND. To solve the problem, AMX always recommends the use of (!A) && B instead of !A && B; however, and this is critical, some programs out there are taking advantage of the logic flow. Where the Access programmer intended the truth table of !(A && B) he/she may have coded !A && B and gotten the desired result. If these systems are converted to NetLinX Masters, the logic will not work as desired.

Please be aware of this difference as you support programs being converted from Access to NetLinX. When it occurs, Access-like operation can generally be achieved by including all the conditions to the right of the NOT in a single set of parentheses. For example:

```
IF (SYSTEM_POWER && ![VCR,PLAY] || [VCR,RECORD])
```

becomes:

```
IF (SYSTEM_POWER && !([VCR,PLAY] || [VCR,RECORD]))
```

Combining Devices, Channels and Levels

Access allows you to combine devices and levels within the DEFINE_COMBINE and DEFINE_CONNECT_LEVEL sections. This method is static and is fixed when the program compiles. You can combine functionality within mainline by stacking push and release statements. Stacking pushes allows you the flexibility to conditionally change what elements of the program share functionality, but the program can be more difficult to maintain over time than if the panels were combined using DEFINE_COMBINE.

NetLinX provides several new methods for combining the functionality of devices, channels, and levels. Using DEV, DEVCHAN and DEVLEV accomplishes the same thing as stacking pushes in Access, and it reduce the overall maintenance associated with stacking pushes; however, data sets are statically implemented within the DEFINE_EVENT section. When the program compiles, the references to the data sets in the DEFINE_EVENT are set and cannot change at run time.

Virtual devices, levels and device/channel sets

One of the drawbacks to combining devices and levels in Access is the way the central controller handled the first device in the combine list going online and offline. This resulted in unexpected device behavior and inconsistent feedback.

NetLinX uses virtual devices. Virtual devices carry a device number ranging from 32,768 to 36,863, a port number of 1, and a system number of 0. Virtual Devices are devices that cannot be taken off the bus. By listing a virtual device as the first device in a DEFINE_COMBINE, COMBINE_DEVICES, COMBINE_LEVELS, or COMBINE_CHANNELS statement, the abnormalities seen in Access DEFINE_COMBINE statements are eliminated.

Combining and Uncombining devices

NetLinX still recognizes the DEFINE_COMBINE section. This section still operates as it did in Access; however, once the DEFINE_COMBINE section has been compiled it remains static. NetLinX introduces two functions: COMBINE_DEVICES and UNCOMBINE_DEVICES. COMBINE_DEVICES and UNCOMBINE_DEVICES dynamically change the devices combined together. When devices are combined the combine list and DEV set lists are reevaluated and updated during run time. COMBINE_DEVICES and UNCOMBINE_DEVICES are used as stand-alone statements in an event, mainline or in assignment statements. COMBINE_DEVICES and UNCOMBINE_DEVICES will return a value of 0 or -1, depending on the success or failure of the operation. The first device in a COMBINE_DEVICES statement should be a virtual device.

The devices, listed after the virtual device, are either a list of individual device numbers, DEV sets, or any combination of devices and DEV sets. The UNCOMBINE_DEVICES statement requires only the first device in the COMBINE_DEVICES list, which should be a virtual device. The format for COMBINE_DEVICES and UNCOMBINE_DEVICES is:

```
COMBINE_DEVICES (<virtual device>, <device1>, <device2>...)
UNCOMBINE_DEVICES (<virtual device>)
```

Devices combined with COMBINE_DEVICES respond like devices combined using the DEFINE_COMBINE section. The central controller recognizes any input from the devices in the combine list as the first device in the list.

Combining and Uncombining levels

The NetLinX functions COMBINE_LEVELS and UNCOMBINE_LEVELS work similar to the DEFINE_CONNECT_LEVEL section in Access. For compatibility with Access code, the DEFINE_CONNECT_LEVEL section is still valid. Like COMBINE_DEVICES, COMBINE_LEVELS and UNCOMBINE_LEVELS can be used within events and mainline code to dynamically change what levels are connected to each other. It is also recommended that a Virtual DEVLEV set be used as the first DEVLEV set in the COMBINE_LEVELS function. The format for COMBINE_LEVELS and UNCOMBINE_LEVELS is:

```
COMBINE_LEVELS (<virtual DEVLEV>, <DEVLEV1>, <DEVLEV2>...)
UNCOMBINE_LEVELS (<virtual DEVLEV>)
```

DEVLEV structures defined within the COMBINE_LEVELS are either individual DEVLEV structures or one dimension of a DEVLEV array. Any reference to the levels is handled through the first device in the list.

Combining and Uncombining channels

Combining DEVCHANs is unique to NetLinX. The NetLinX function COMBINE_CHANNELS combines an individual channel on a virtual device to one or more channels on another device (or devices). The format for COMBINE_CHANNELS and UNCOMBINE_CHANNELS is:

```
COMBINE_CHANNELS (<virtual DEVCHAN>, <DEVCHAN1[]>, <DEVCHAN2[]>...)
UNCOMBINE_CHANNELS (<virtual DEVCHAN>)
```

String Comparisons

While in Access it is possible to perform a string comparison using the '?' wildcard, NetLinX requires the COMPARE_STRING function to be used instead.

Access code - string comparison

```
IF (TIME = '12:00:??')
(* Do something at noon - evaluation is valid for an entire minute *)
```

NetLinX code - string comparison

```
IF (COMPARE_STRING(TIME,'12:00:??'))
// Do something at noon - evaluation is valid for an entire minute
```

Modules

There are two ways to reuse code in different Access programs: *Include Files* and *System Calls*.

- Include files redirect the compiler to files with an .AXI extension. The .AXI files can contain the same type of information present within an Access program. All data is accessible both within the Include file and within the primary Access program. Include files are limited because they are static. Mainline statements within the Include file cannot be adapted from program to program without altering the Include file. To update the Include files in a program, the entire program must be compiled and loaded.
- System calls are external subroutines that can be instanced and referenced in the main program. Like DEFINE_CALL subroutines, System Calls can pass parameters to adapt the System Call to the needs of different programs. System Calls have been one of the primary tools for creating standardized reusable blocks of code. To update the System Calls within a program, the entire program must be compiled and loaded.

Modules are unique to NetLinX. Like Include files, the code within the Module is not limited to the DEFINE_CALL section. Modules can contain variable definitions, functions, subroutines, startup code, events, and mainline. Modules are passed parameters that are used to adapt the information and variables used within the Module (similar to System calls).

Modules are similar to programs loaded into AXB-232++ boxes. They operate as stand-alone programs inside the NetLinX program. Interaction between the Module and the NetLinX Program is done through User Interface (UI) pushes and releases, turning virtual device channels on and off, and passing variables and arrays to the Module. The code in the Module is local, or is restricted to use only within the Module. This means that functions and subroutines defined with Module cannot be directly used with the main NetLinX code.

Modules will eventually replace System calls. Where several system calls are currently needed to provide device initialization, buffer processing, and device functionality, one module will handle all three functions.

The first line of a Module contains the MODULE_NAME keyword, the Module name, and the parameter list. The format is shown below:

```
MODULE_NAME = '<module name>' [(<param1>, <param2>, ... , <paramN>)]
```

The <module name> must match the file name, but has the .AXS extension. The module name can be 64 characters long and contain valid file name characters. The parameter name is optional and follows the same restrictions as subroutine parameters, with the exception that constants and expressions cannot be used as arguments. Within the NetLinX program, the Module is referenced using the following format:

```
DEFINE_MODULE '<module name>' <instance name> [(<pass1>, <pass2>, ... , <passN>)]
```

The <module name> must match the module name specified in the Module file, as shown above. The <instance name> is a unique name given to each occurrence of the module within the program. If the module is used twice within the program, each occurrence gets a unique instance name. The parameter list passed to the module must match number and types of parameters listed in the module file above. The DEFINE_MODULE statements are listed in the code after the DEFINE_CALL and DEFINE_FUNCTION sections, but before the DEFINE_START section. The DEFINE_MODULE statements cannot appear within the DEFINE_PROGRAM or DEFINE_EVENTS section.

NOTE: *To use a module, the module must be compiled with the Source Code, and the Master must be rebooted to run the new module.*



© 2024 Harman. All rights reserved. NetLinx, AMX, AV FOR AN IT WORLD, and HARMAN, and their respective logos are registered trademarks of HARMAN. Oracle, Java and any other company or brand name referenced may be trademarks/registered trademarks of their respective companies. AMX does not assume responsibility for errors or omissions. AMX also reserves the right to alter specifications without prior notice at any time. The AMX Warranty and Return Policy and related documents can be viewed/downloaded at www.amx.com.
3000 RESEARCH DRIVE, RICHARDSON, TX 75082 AMX.com | 800.222.0193 | 469.624.8000 | +1.469.624.7400 | fax 469.624.7153
AMX (UK) LTD, AMX by HARMAN - Unit C, Auster Road, Clifton Moor, York, YO30 4GD United Kingdom • +44 1904-343-100 • www.amx.com/eu/

Last Revised:
2024-10-17