

NOTES: UNLESS OTHERWISE SPECIFIED

1. ALL DIMENSIONS IN INCHES AND DIMENSIONS IN [ ] ARE IN MILLIMETERS.

REVISION HISTORY					
DATE	REV.	PREVIOUS PART NO.	DESCRIPTION	ZONE	BY
05/12/17	A		INITIAL RELEASE		P. LE

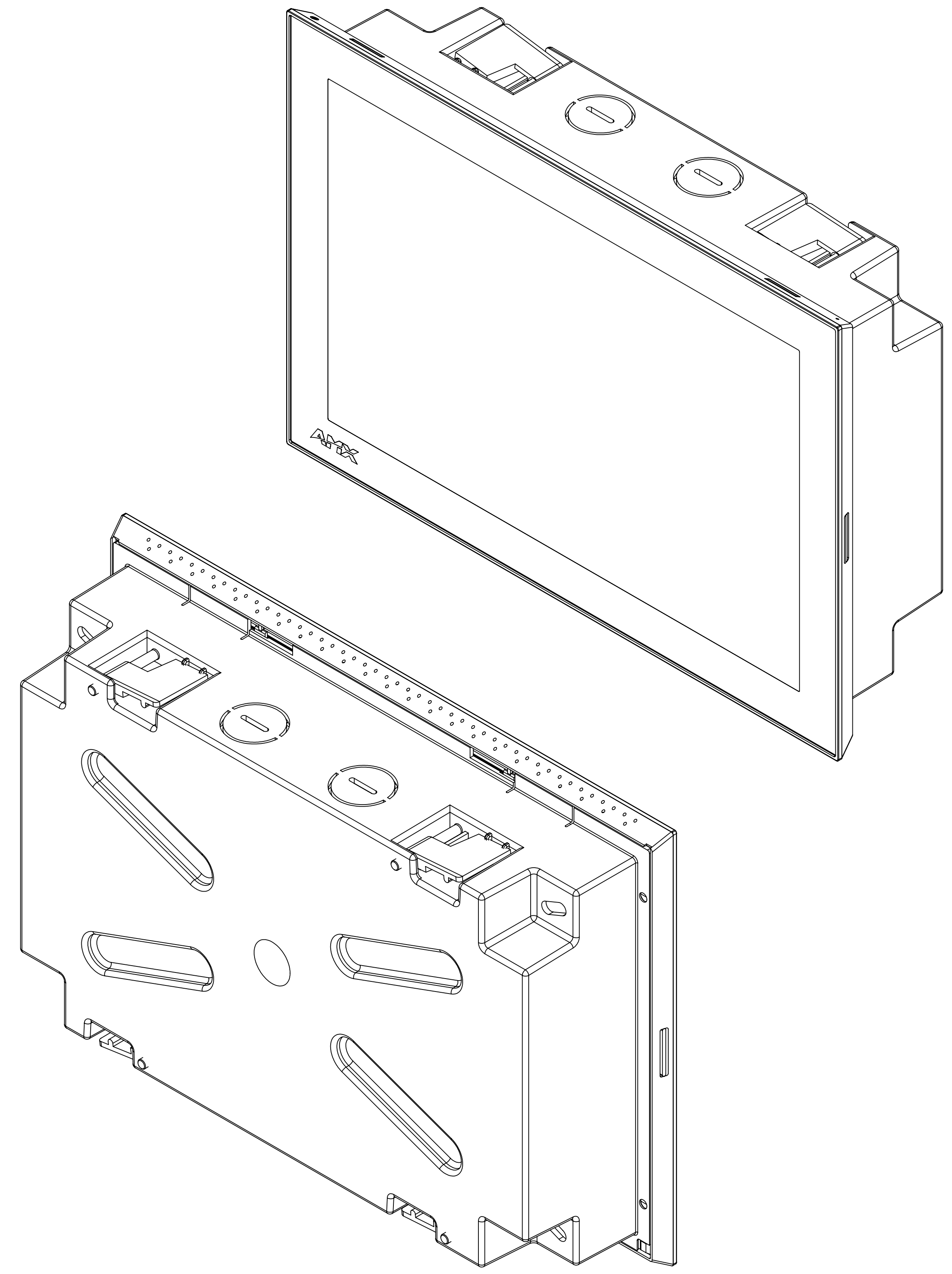
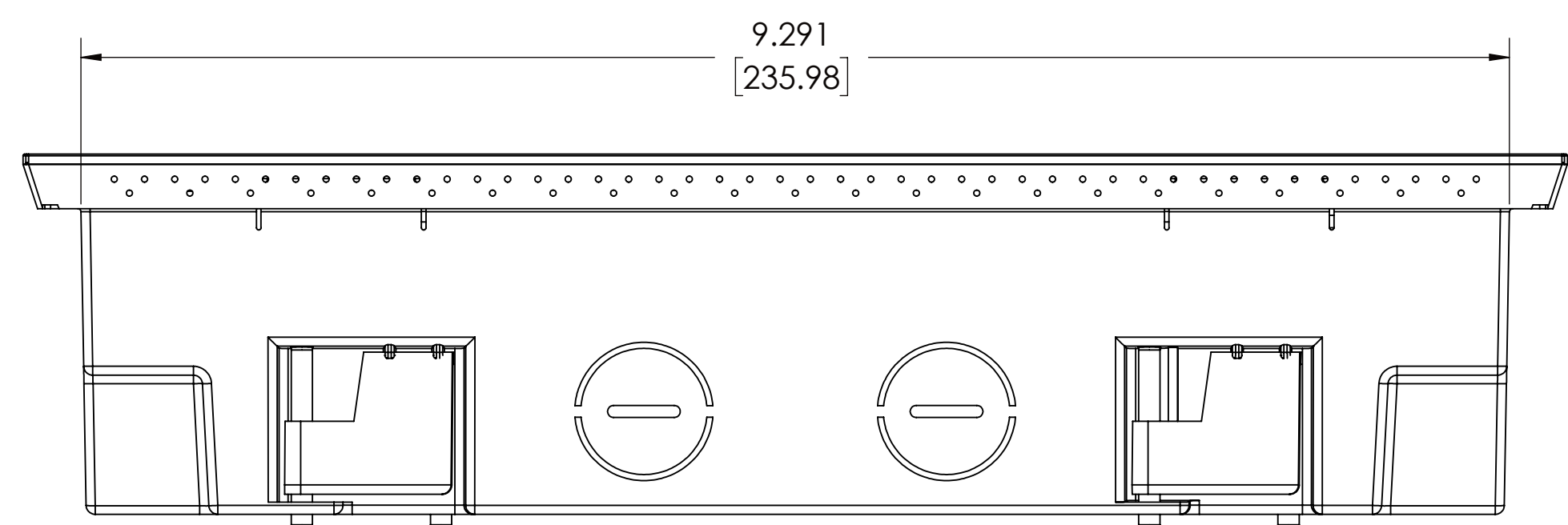
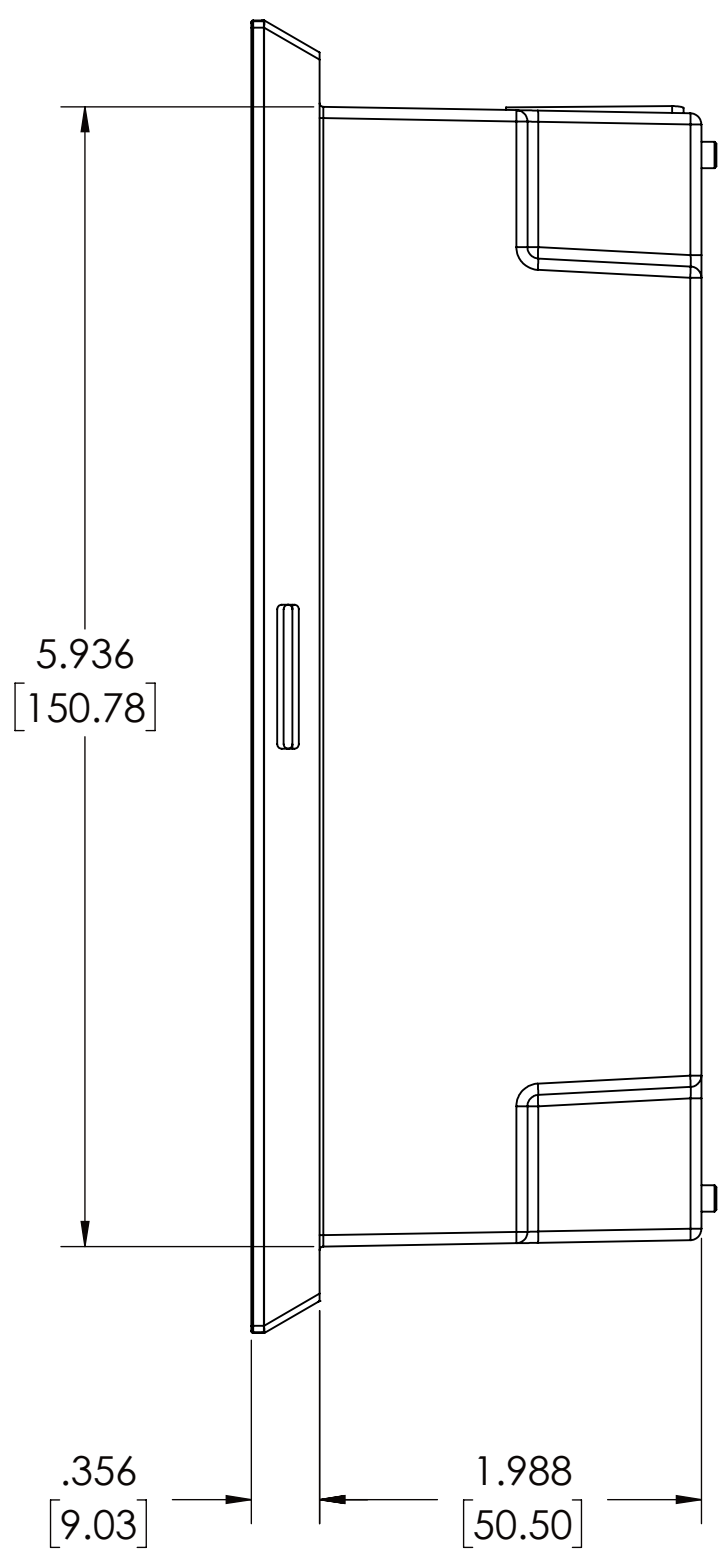
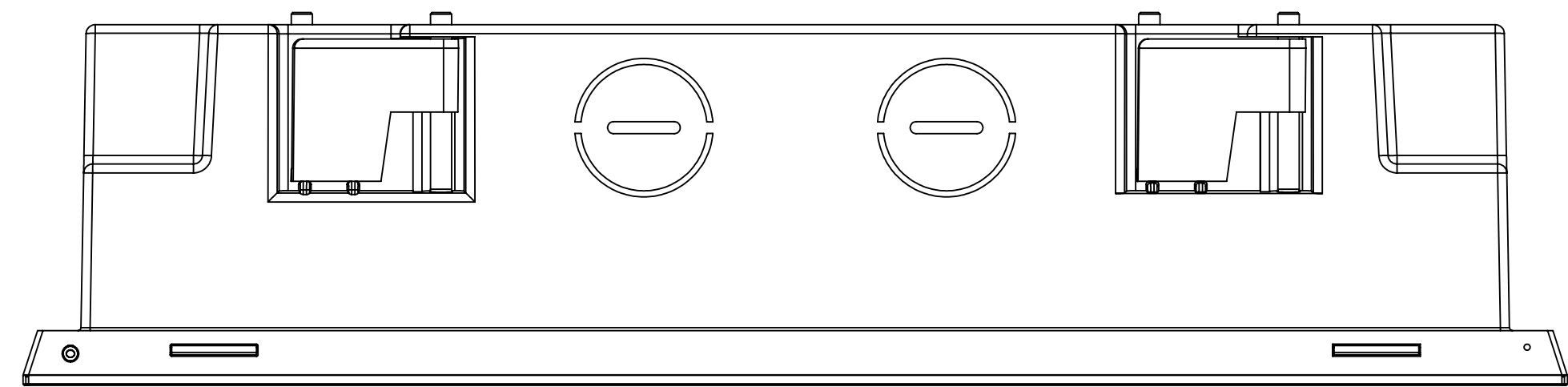

<small>PROPRIETARY AND CONFIDENTIAL PROPERTY OF HARMAN. DO NOT DISCLOSE, REPRODUCE, OR FURNISH WITHOUT WRITTEN HARMAN APPROVAL.</small>	<small>TOLERANCES UNLESS OTHERWISE SPECIFIED: Bend to Bend: ± 0.15 Bend to Feature: ± 0.10 Feature to Feature: ± 0.05 Feature Tolerance: ± 0.05 Angle: ± 5°</small>	<small>THIRD ANGLE PROJECTION</small>	<b>HARMAN</b> <small>3000 Research Dr Richardson, TX 75082 USA</small>				
			<small>RESTRICTION OF HAZARDOUS SUBSTANCES ALL MATERIALS USED IN THIS PART MUST BE ROHS COMPLIANT. SUPPLIER SHALL PROVIDE A CERTIFICATE OF ROHS COMPLIANCE WITH THE FIRST ARTICLE.</small>	<small>ROHS</small>	<small>DATE</small> 4/29/2013	<small>DATE</small> 3/31/2013	<small>NO.</small> 5088961-00
<small>ALL DIMENSIONS ARE IN INCHES ALL DIMENSIONS APPLY AFTER FINISH DIMENSIONS SHOWN ARE FOR REFERENCE AND INSPECTION ONLY. REFER TO CAD MODEL DRAWING WITH THIS SHEET FOR ORIGINAL DEFINITION OF PART GEOMETRY.</small>			<small>SIZE</small> D	<small>SCALE</small> 1:1	<small>DO NOT SCALE DRAWING</small>	<small>SHEET</small> 1	<small>OF</small> 1