

REVISION HISTORY			
DATE	REV.	DESCRIPTION	BY
2022/11/30	C	Update to Harman DWG format	PXiong

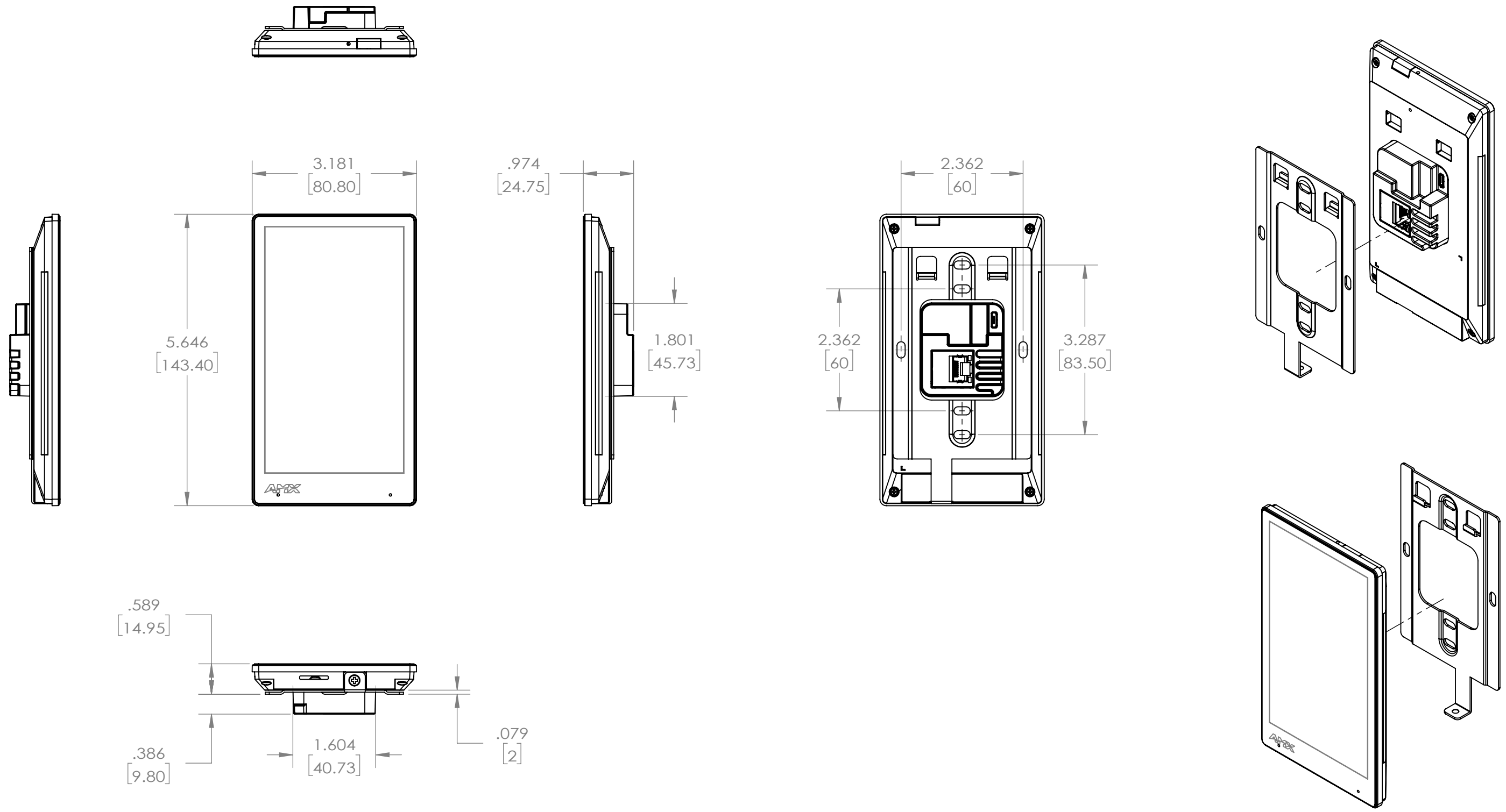

NOTES:
 1. Unit: inch / [mm]
 2. Detailed dimension refer to DXF/DWG files.

2022 © HARMAN INTERNATIONAL INDUSTRIES, INCORPORATED. ALL RIGHTS RESERVED. DO NOT USE, DISCLOSE, SELL, REPRODUCE, PUBLISH OR MODIFY WITHOUT AUTHORIZED WRITTEN HARMAN PERMISSION.

ROHS
 RESTRICTION OF HAZARDOUS SUBSTANCES
 ALL MATERIALS USED IN THIS PART MUST BE ROHS COMPLIANT
 SUPPLIER SHALL PROVIDE A CERTIFICATE OF ROHS COMPLIANCE WITH THE FIRST ARTICLE.

THIRD ANGLE PROJECTION

DRAWN BY _____ DATE _____

DESIGNED BY _____ DATE _____

PROJECT MANAGER/ENGINEER _____

DIMENSIONS SHOWN ARE FOR REFERENCE AND INSPECTION ONLY. REFER TO CAD MODEL PROVIDED WITH THIS DRAWING FOR OVERALL DEFINITION OF PART GEOMETRY.

HARMAN

TITLE: DWG, PICTORIAL, AMX-UTP0501

NO. **AMX-UTP0501** REV **C**

SIZE **B** SCALE **1:2** DO NOT SCALE DRAWING SHEET **1** OF **1**