

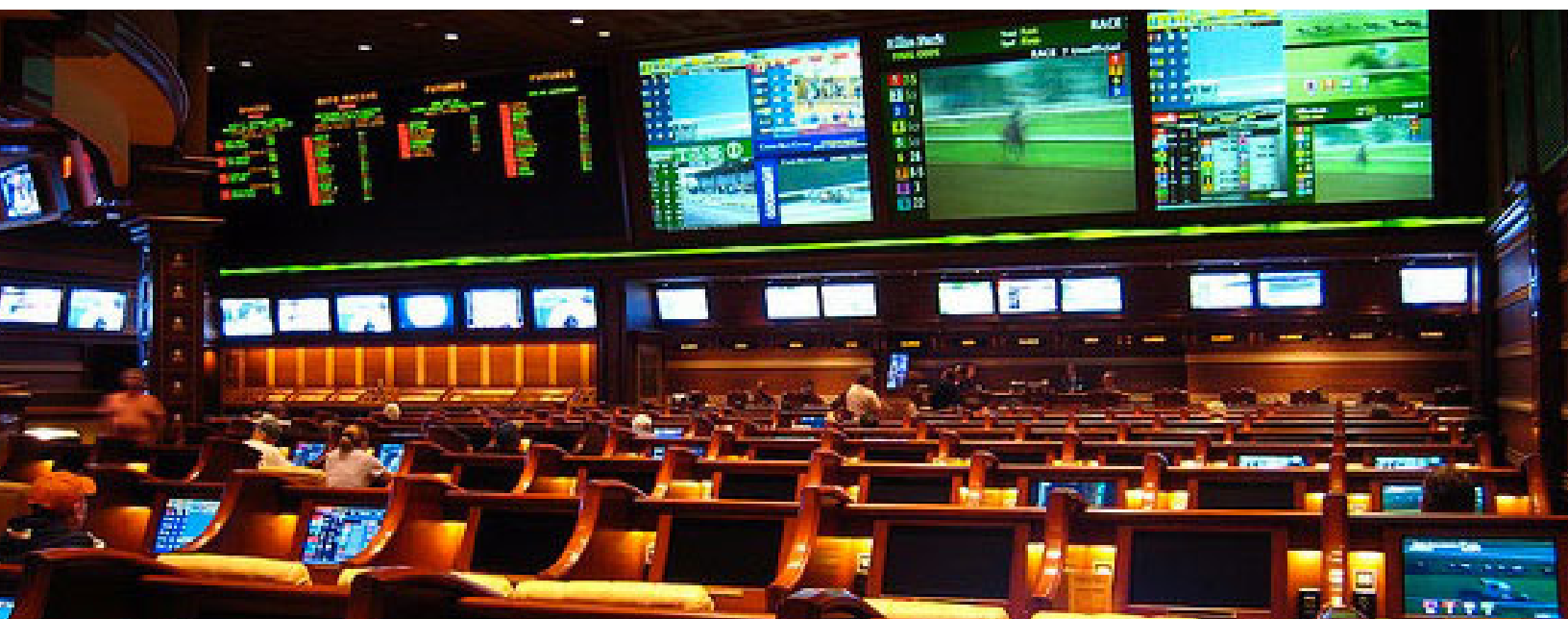

N2000 Series

Digital Media Distribution & Switching Solution

User Manual



SVSi N-Series Encoders/Decoders

N2121/N2211/N2221

N2141/2241

Table of Contents

Chapter 1. Introduction

Product Overview	8
HD AV over IP Series	8
N2121 HD AV over IP Encoder	8
N2211 HD AV over IP Decoder (non-PoE)	8
N2221 HD AV over IP Decoder	8
Low-Latency AV over IP Series	9
N2141 Low-Latency AV over IP Encoder	9
N2241 Low-Latency AV over IP Decoder	9
Rear Panel Ports and LEDs	9
Application Examples	12

Chapter 2. Installation

Introduction	15
Installation Overview	15
Mounting Options	17
Surface and Wall Mounting	17
Rack Mounting Options	18
N2000 Series Stand-Alone Units	18
N2000 Series Cards	18
Step-by-Step Installation Instructions	20
Setting Up Your Host Computer	21
Connecting Decoders to the Network	23
Connecting Encoders to the Network and Configuring Stream Settings	25
Configuring Decoder and Encoder IP addresses (if needed)	29
How IP Address Changes Affect Unit Control	29
Changing IP Addresses	29
Option 1: Assigning IP Addresses Individually (using the Settings page)	29
Option 2: Assigning IP Addresses to Multiple Units (using CSV files)	30
Connecting Encoders to an Input Source	31
Switching and Scaling Options	32
Seamless Switching	32
Control Options	33
Primary Control Options	33
N-Command Controllers	33
Third-Party Controllers	33
Other Control Options	33
N-Act On-Board, Built-In Control	33
N-Touch IP Wall Controller	33
Software Bundles Included With N-Command	34

Chapter 3. Encoder Options

Encoder Introduction	36
Encoder Configuration Options	36
Settings Page	37
Encoder Setup Section	38
Advanced Settings	42

RS232 Settings	46
Network Setup Section	47
Status Section	49
Change Password	51
Software Section	52
EDID Section	53
DVI Pass Thru Settings	55
Crop/Pan/Zoom Page	56
IR Page	60
N-Act Page	61
Serial Page	63
EDID Page	65
Logs Page	66
LLDP Page	67
Chapter 4. Decoder Options	
Decoder Introduction	68
Decoder Configuration Options	68
Settings Page	69
Decoder Setup Section	70
Advanced Settings	73
RS232 Settings	77
Network Setup Section	78
Status Section	80
Change Password	82
Software Section	83
EDID Section	84
Audio Downmixer Settings	85
Crop/Pan/Zoom Page	86
LocalPlay Page	88
IR Page	90
N-Act Page	91
Serial Page	93
EDID Page	95
Logs Page	96
LLDP Page	97
Chapter 5. Troubleshooting	
Introduction	98

Trademarks

SVSi is a trademark of Southern Vision Systems, Inc. in the United States and other countries. All other brand names, product names and trademarks are the property of their respective owners. Certain trademarks, registered trademarks, and trade names may be used to refer to either the entities claiming the marks and names or their products. SVSi disclaims any interest in the marks and names of others.

To the Reader

The contents of this manual are current as of the date of publication. SVSi reserves the right to change the contents without prior notice.

In no event will SVSi be liable for any special, incidental, or consequential damages or for commercial losses (even if SVSi has been advised thereof) that result from issue or use of this publication.

Information in this document (including URL and other Internet website references) could change without notice.



360B Quality Circle NW Suite 200,
Huntsville, AL 35806

Phone: 256.461.7143

Fax: 256.461.7145

Email: info@svsiav.com

Support Email: support@svsiav.com

Website: www.svsiav.com

All Rights Reserved.



Printed in U.S.A.

Conventions



Notes provide additional useful information.



Cautions provide information that could prevent service interruption or damage to the equipment.

Safety Instructions

Please read the safety precautions carefully before using this product. Ensure that you use the product correctly according to the procedures described in these instructions.

The following safety precautions are intended to instruct you in the safe and correct operation of the product and its accessories to prevent injuries or damage to yourself, other persons, and property. Please read and ensure that you understand them before you proceed to the other sections of these instructions.

- Do not operate this device in a wet environment.
- Refer servicing to qualified service personnel only.
- Please read this user manual and other provided documentation carefully before operating. Follow all operating and other instructions carefully.
- Do not use this product near heat sources such as radiators, air ducts, areas subject to direct, intense sunlight, or other products that produce heat.

Disclaimer

- While every effort has been made to ensure that the information contained in these instructions is accurate and complete, no liability can be accepted for any errors or omissions. SVSi reserves the right to change the specifications of the hardware and software described herein at any time without prior notice.
- SVSi makes no warranties for damages resulting from corrupted or lost data due to mistaken operation or malfunction of the hardware, software, or accessories.



Caution: Changes or modifications to this unit not expressly approved by the party responsible for compliance could void the user's authority to operate the equipment.

FCC Class A Notice

This equipment has been tested and found to comply with the limits for a Class A digital device, pursuant to Part 15 of the FCC Rules. Operation is subject to the following two conditions: (1) this device may not cause harmful interference, and (2) this device must accept any interference received, including interference that may cause undesired operation. The Class A limits are designed to provide reasonable protection against harmful interference when the equipment is operated in a commercial environment. This equipment generates, uses, and can radiate radio frequency energy and, if not installed and used in accordance with the instruction manual, may cause harmful interference to radio communications. Operation of this equipment in a residential area is likely to cause harmful interference, in which case the users will be required to correct the interference at their own expense.

To comply with FCC and Industry Canada RF exposure limits, this device must be installed to provide a separation distance of at least 20 cm from all persons and must not be co-located or operating in conjunction with any other antenna or transmitter.



Caution: These units contain no user-serviceable parts. They should only be serviced by qualified service personnel. Opening the unit could void the warranty.

Service and Warranty

For information on the service and warranty of SVSi products please visit our website at www.svsiv.com.

Chapter 1

INTRODUCTION

Introducing Your New N2000 Series

PRODUCT OVERVIEW

SVSi's N2000 AV over IP Series provides a flexible, feature-rich, and simple-to-deploy digital media distribution and switching solution satisfying the most demanding applications. SVSi video over IP Encoders are used to encode and distribute sources of almost any format onto an existing IP network, making that stream available to any endpoint in the facility. Video over IP Decoders are used to decode SVSi's Networked audio/video (AV) streams back to DVI or HDMI format for display on any monitor. With the ability to direct any source stream to any display, large, low-cost switching and distribution systems are simple to deploy without proprietary cabling or dedicated switching hardware. Plug-n-play, auto-detect technology reduces installation and programming time.

Features include:

- 1080p/60Hz encoding and decoding (applies to N2141 and N2241).
- Backwardly compatible with SVSi's V-Series products.
- Input and Output Scaling – scaling performed in Encoders or Decoders for maximum flexibility with V-Series sources and displays.
- Power over Ethernet (PoE) – eliminates the need for a local power supply and speeds installation. Units can still be powered locally by 12VDC. This allows easy rack-mountable, high-density installations. (All units can be PoE powered except the N2211 Decoder.)
- Infrared (IR) emitter connection allows control of low-cost, IR-only display devices.
- Fast install with Phoenix connectors for power, IR, RS232 serial, and analog audio interfaces.
- Pass-through DVI interface allows easy installation with local display, such as desktop PC applications.

HD AV over IP Series

The SVSi HD AV over IP Series includes the N2121 Encoder, the N2211 Decoder, and the N2221 Decoder. This series uses JPEG2000 compression to provide user-definable bandwidth consumption controls.

N2121 HD AV over IP Encoder

This JPEG2000 Encoder includes IR, serial, balanced audio, two network ports (one PoE), and a local video pass-through port. The unit accepts (auto-senses) analog or digital video input.

N2211 HD AV over IP Decoder (non-PoE)

This JPEG2000 Decoder includes serial and a single network port (non-PoE). The unit provides digital video output only and requires the N9312 external power supply (included in shipment).

N2221 HD AV over IP Decoder

This JPEG2000 Decoder has expanded LocalPlay and includes IR, serial, balanced audio, and two network ports (one PoE). The unit provides digital video output only.

Low-Latency AV over IP Series

SVSi's low-latency AV over IP Series includes the N2141 Encoder and the N2241 Decoder. This series provides low latency for 1080p/60Hz encoding and decoding.

N2141 Low-Latency AV over IP Encoder

This low-latency Encoder includes IR, serial, balanced audio, two network ports (one PoE), and a local video pass-through port. The unit accepts (auto-senses) analog or digital video input.

N2241 Low-Latency AV over IP Decoder

This low-latency Decoder has expanded LocalPlay and includes IR, serial, balanced audio, and two network ports (one PoE). The unit provides digital video output only.

REAR PANEL PORTS AND LEDS

See [Figure 1-1](#), [Figure 1-2](#), and [Figure 1-3](#) to identify the ports on the back of your Encoders and Decoders.

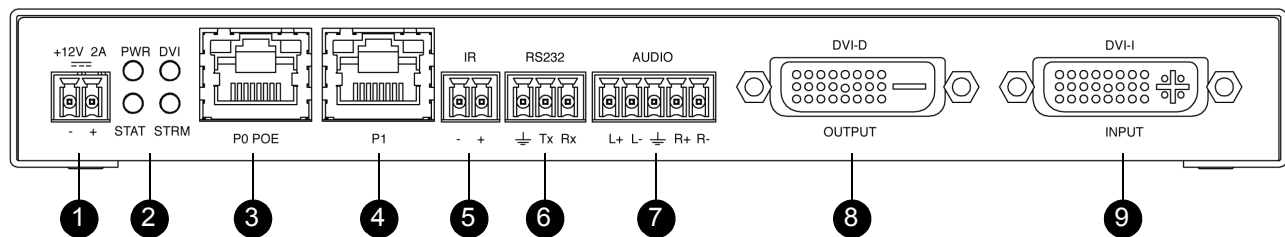

- | | |
|---|----------------------------------|
| 1) 12VDC Input (not needed with PoE) | 6) RS232 Connection |
| 2) Status Indicators | 7) Analog Audio Input Connection |
| 3) RJ45 Auto-Sensing Gigabit Ethernet Switch Port — PoE | 8) Pass-Through DVI-D Connection |
| 4) RJ45 Auto-Sensing Gigabit Ethernet Switch Port | 9) DVI-I Digital Input |
| 5) IR Emitter Connection | |

Figure I-1. N2121/N2141 Encoder Rear Panel

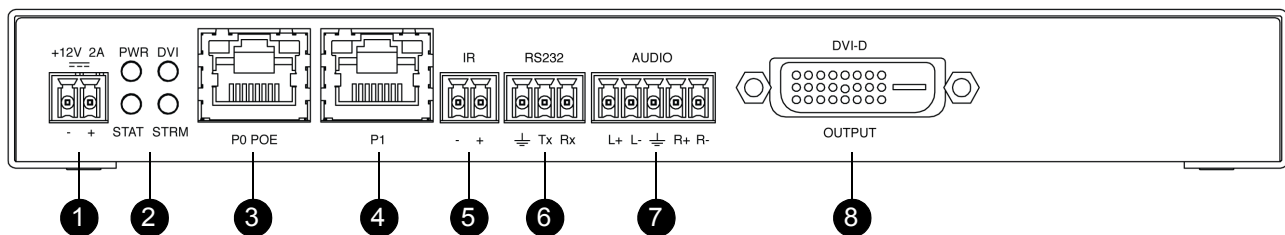

- | | |
|---|-----------------------------------|
| 1) 12VDC Input (not needed with PoE) | 5) IR Emitter Connection |
| 2) Status Indicators | 6) RS232 Connection |
| 3) RJ45 Auto-Sensing Gigabit Ethernet Switch Port — PoE | 7) Analog Audio Output Connection |
| 4) RJ45 Auto-Sensing Gigabit Ethernet Switch Port | 8) DVI-D Digital Output |

Figure I-2. N2221/N2241 Decoder Rear Panel

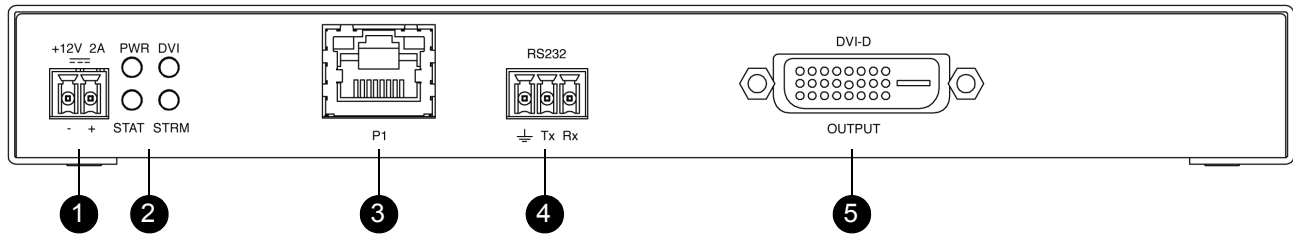

- 1) 12VDC Input (external power required)
- 2) Status Indicators
- 3) RJ45 Auto-Sensing Gigabit Ethernet Switch Port
- 4) RS232 Connection
- 5) DVI-D Digital Output

Figure I-3. N221 I Decoder Rear Panel

Table I-1. Rear Panel Descriptions

+12V 2A	12 Volt DC power input.
PWR LED	On solid (green) when operating power is supplied (via PoE or local power supply). This activity is also shown by the PWR LED on the front panel.
DVI LED	On (green) when a DVI output connection exists.
STAT LED	On flashing (green) when there is software activity. This activity is also shown by the STAT LED on the front panel.
STRM LED	On (green) when the unit is streaming video.
P0 POE	8-wire RJ45 female. 10/100/1000 Mbps 10/100/1000Base-T auto-sensing gigabit Ethernet switch port. Provides both the network connection and the power to the Encoders and Decoders. <i>*Not available on the N2211 Decoder.</i>
P1	8-wire RJ45 female. 10/100/1000 Mbps 10/100/1000Base-T auto-sensing gigabit Ethernet switch port.
IR	2-pin terminal Phoenix connector. Provides IR output only (33 to 60 kHz). An emitter may be necessary (not included). <i>*Not available on the N2211 Decoder.</i>
RS232	3-pin terminal Phoenix connector which provides a serial control interface. Full duplex communication. Available terminal speed settings: 1200 to 115200 baud rate.

Table I-1. Rear Panel Descriptions (Continued)

AUDIO	5-pin terminal Phoenix connector which provides user-selectable balanced/unbalanced input. Dedicated audio output. <i>*Not available on the N2211 Decoder.</i>
DVI-D OUTPUT	DVI-D female; HDMI/DVI digital video/audio output. Allows for video and embedded digital audio output.
DVI-I INPUT	DVI-I female; HDMI/DVI digital video/audio input. Allows for the use of analog or digital video sources (as well as embedded audio). <i>*Applies to Encoders only.</i>

APPLICATION EXAMPLES

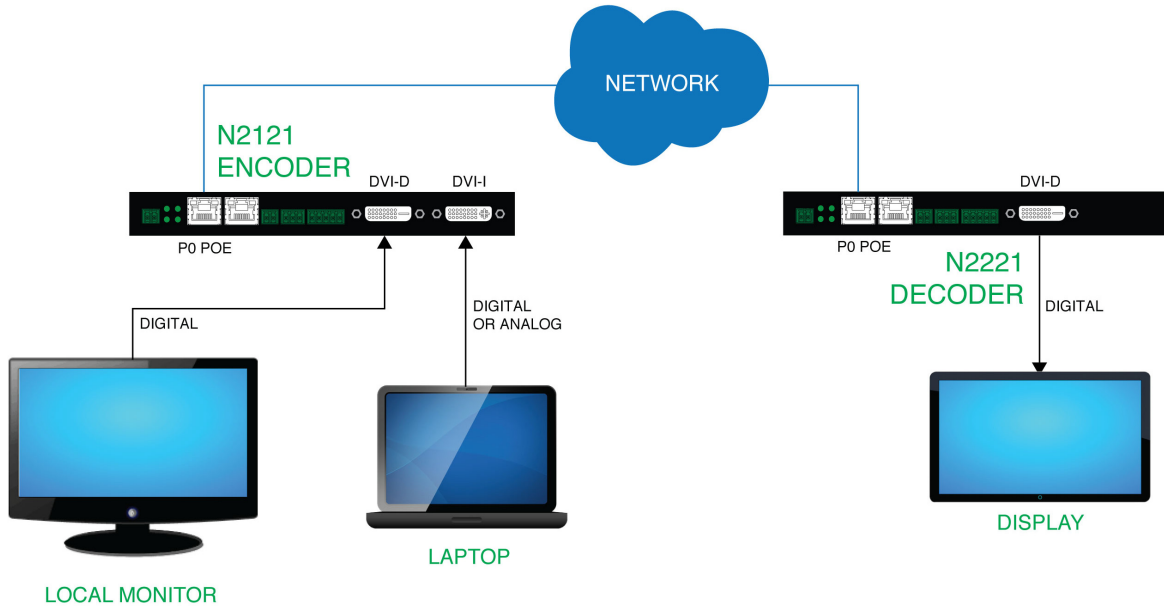

Figure I-4. Loop Through DVI Port on Encoder

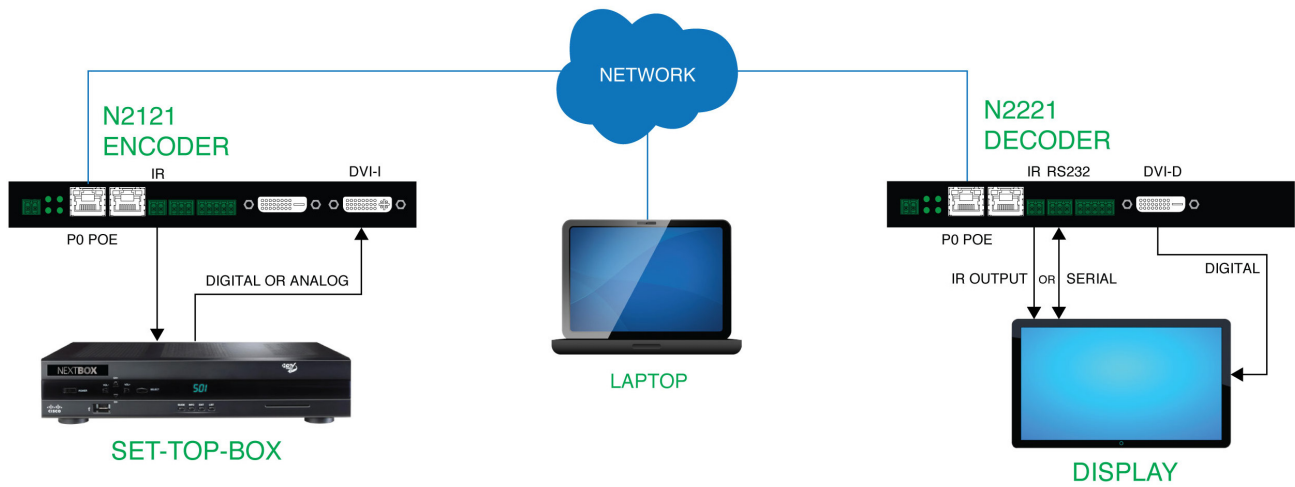

Figure I-5. IR and Serial Transmitter Port

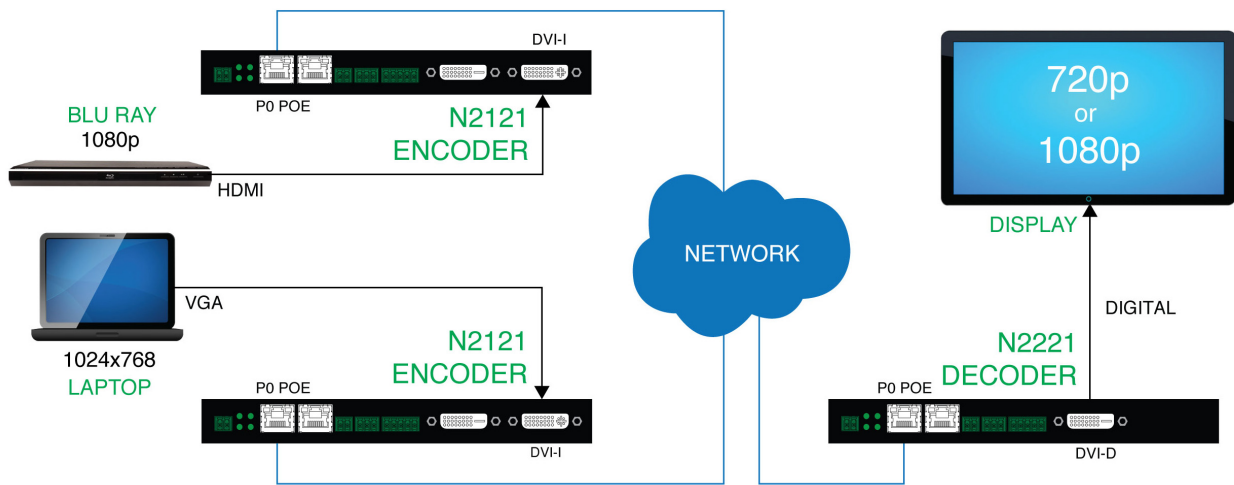

Figure I-6. Built-In Scaling Through Encoders and Decoders

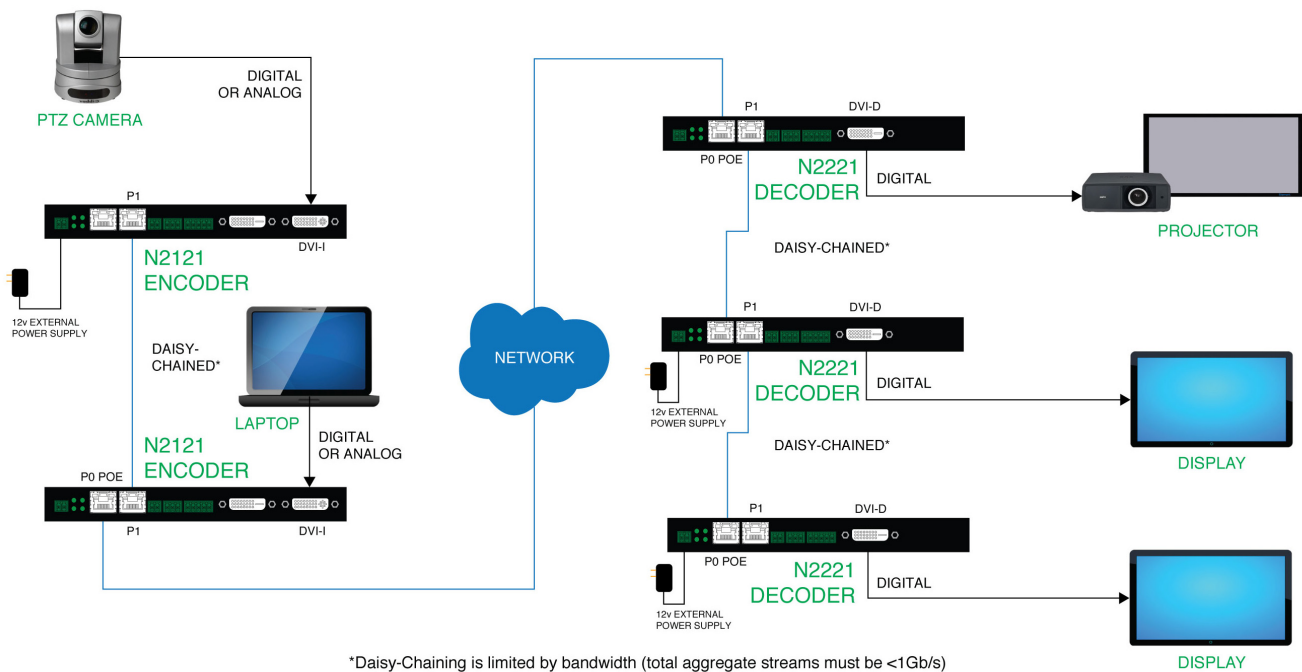
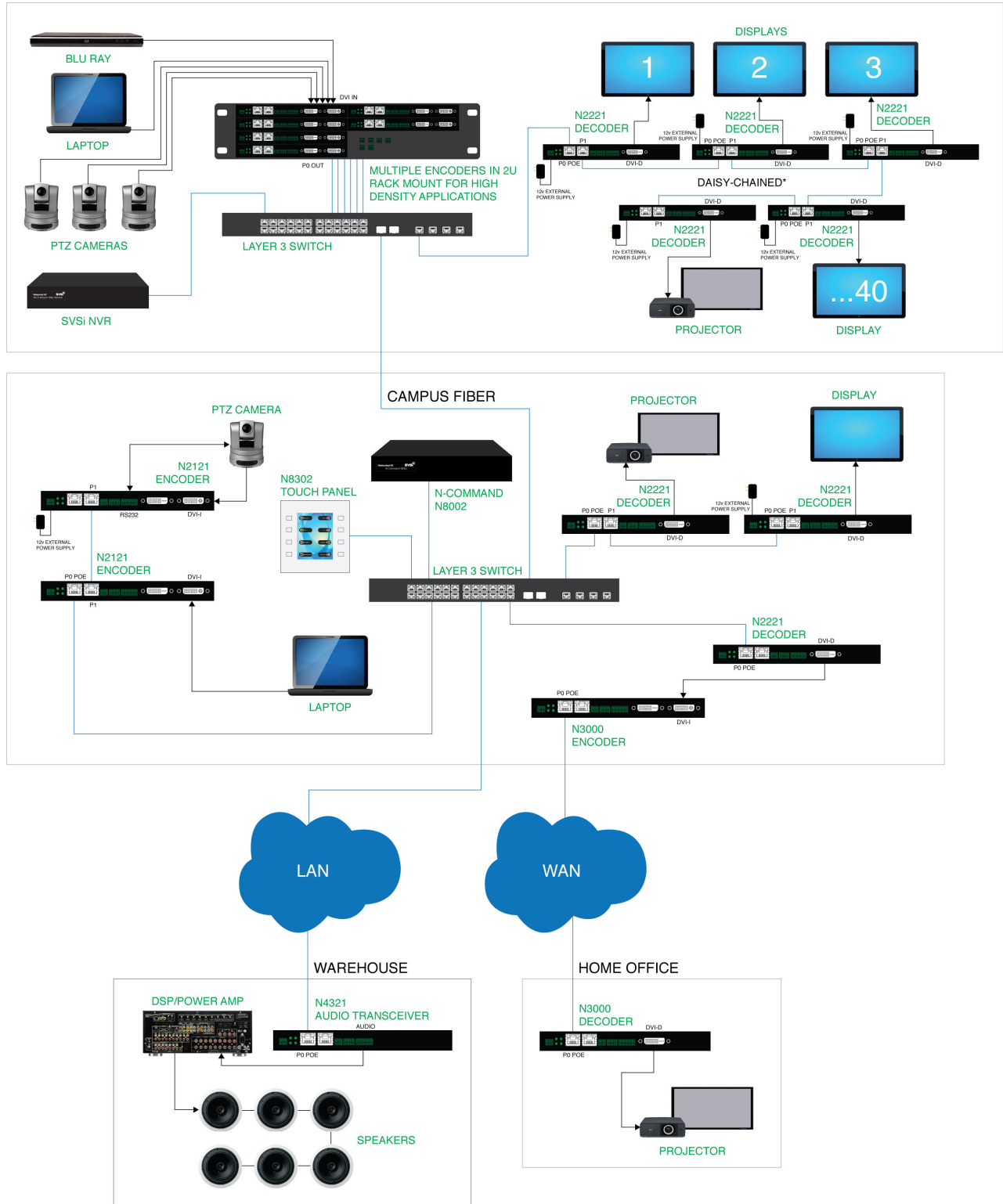

Figure I-7. Basic Networked AV



*Daisy-Chaining is limited by bandwidth (total aggregate streams must be <1Gb/s)

Figure I-8. Multi-Switch Enterprise Network

INSTALLATION

Installing and Configuring Your AV Equipment

INTRODUCTION

This chapter provides an installation overview as well as a detailed step-by-step process for installation.

INSTALLATION OVERVIEW

The N2000 Encoders and Decoders have multiple configuration and installation options. For basic installation guidelines, see [Table 2-1](#). For more detailed instructions, refer to [Step-by-Step Installation Instructions](#) on page 20.

Table 2-1. Basic Installation Guidelines

Connections	Options
Power	Power over Ethernet (PoE): Connect the unit's P0 port to an active, PoE-enabled network switch (not supported on the N2211 Decoder).
	External power supply: If not using PoE for power, connect a 12V regulated power supply (SVSi part number N9312) to the unit's two-pin terminal block plug connector labeled +12V 2A .
Network	PoE units: If using PoE to power the unit, you should already have a network connection.
	Externally powered units: If not using PoE, connect either the P0 or P1 port to the network using an Ethernet cable.
	Daisy-chain configuration: Once network connection is established to one unit, you can daisy chain additional units by connecting Ethernet cables between devices using their P0 and/or P1 ports. Keep in mind that the number of units supported in this configuration is limited by bandwidth (total aggregate streams must be less than 1 Gb/s). Note: PoE power is only supplied to the unit connected <u>directly to the network</u> . All other units in the daisy-chain must have an external power supply.
Video	N2000 Encoders <ul style="list-style-type: none"> For video encoding of a <i>digital</i> source, connect the source to the Encoder's DVI-D port using a video cable with a DVI-D connector (or adapter). For video encoding of a <i>digital or analog</i> source, connect the source to the Encoder's DVI-I port using a video cable with a DVI-I connector (or adapter).
	N2000 Decoders <ul style="list-style-type: none"> For video decoding, connect a digital display to the Decoder's DVI-D port using a video cable with a DVI-D connector (or adapter).

Table 2-1. Basic Installation Guidelines (Continued)

Connections	Options
Audio	<p>N2000 Encoders</p> <ul style="list-style-type: none"> • For audio encoding, connect a line level analog audio source to the Audio input terminal block plug connector, or • Use the embedded audio from the video source.
	<p>N2000 Decoders</p> <ul style="list-style-type: none"> • For audio decoding, connect a line level analog audio device to the Audio output terminal block plug connector, or • Send audio embedded in the video connection to a monitor's speakers.



Note: When the unit is not in use, remove the power cable and disconnect any other cables (e.g., Ethernet, audio, video) connected to the Encoders and Decoders.

*Note: DVI-D output is the digitally converted analog signal from the DVI-I input. An appropriate adapter or interface cable is required for DVI to accommodate HDMI. With the correct adapter, the **DVI-I Input** port accepts component signals.*

MOUNTING OPTIONS

The N2000 units are available in stand-alone and card versions. The stand-alone version can be free standing, surface mounted, wall mounted, or rack mounted. All cards *must be rack mounted* using the N9206 Card Cage (sold separately).

Surface and Wall Mounting

To mount your N2000 stand-alone unit to a flat surface or wall, follow these steps:

1. Remove the four screws from the bottom of the unit and use them to attach the mounting wings (not included in shipment - SVSi part number N9101). See [Figure 2-1](#).
2. Place the unit against the solid surface to which you want it mounted.
3. Using standard hardware, attach the unit through each of the slots of the newly-attached mounting wings.
4. Connect the appropriate cables necessary for your application. Refer to the sections [Connecting Decoders to the Network](#) on page 23 and [Connecting Encoders to the Network and Configuring Stream Settings](#) on page 25 for more information on these connections.

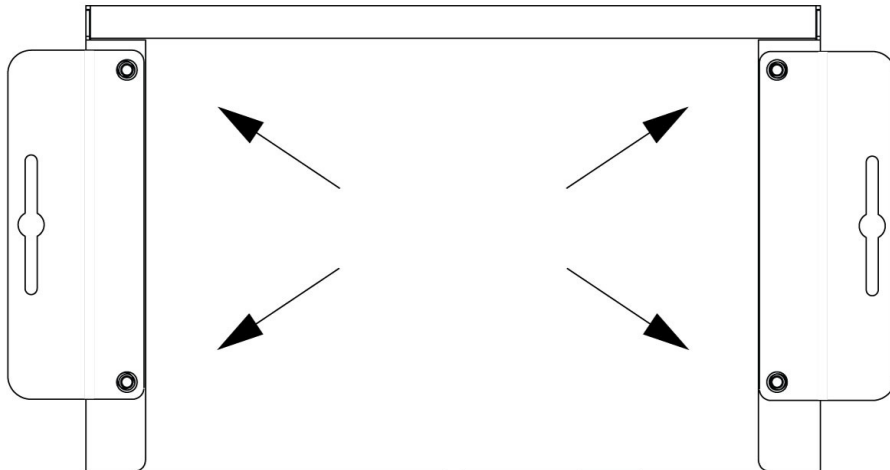

Figure 2-1. Installing Mounting Wings

Rack Mounting Options

N2000 Series Stand-Alone Units

A Rack Shelf (SVSi part number N9102) accommodates up to two stand-alone N-Series Encoders or Decoders, side by side (mix and match).

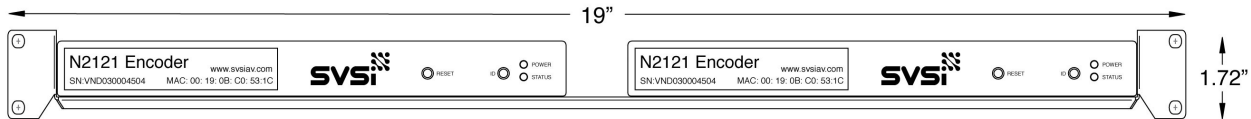

Figure 2-2. Rack Mounting Stand-Alone Units

N2000 Series Cards

A Card Cage (SVSi part number N9206) accommodates up to six N-Series Encoder/Decoder cards (mix and match). The 12V power supply of the N9206 is the primary power source for the installed cards. If the 12V power supply fails or is unplugged, the cards will power down, detect PoE (if provided by switch) and restart normally using PoE. This usually results in a power loss of about one to two seconds. The unit then reboots (which takes another one to two minutes).

To rack mount N2000 Series cards into the N9206 Card Cage, follow these steps:

1. Gently slide the card into cage slot. Make sure the card is properly aligned with guides. The card's front LED indicators should align with holes in the cage's faceplate. See [Figure 2-3](#).

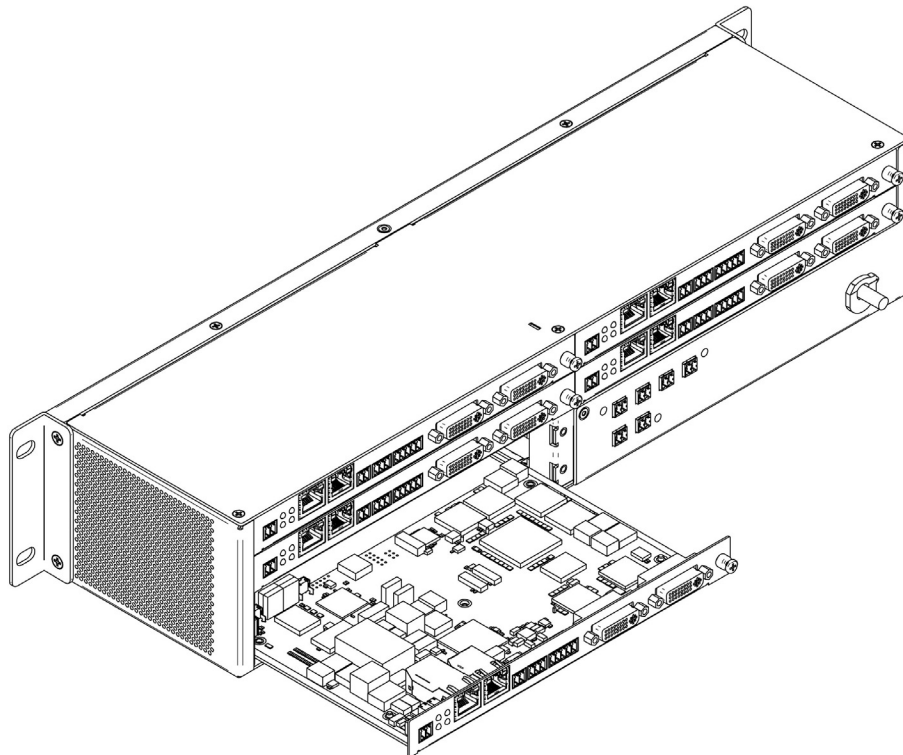

Figure 2-3. Rack Mounting Cards

2. Align the thumb screw on back plate before seating card into cage.
3. Firmly seat the card and tighten the thumb screw by hand to secure card placement.
4. Use one of the six Phoenix connector cables (included in shipment with the Card Cage) to connect the card's 12VDC input Phoenix connector to one of the cage's six 12VDC outputs.
5. Repeat these steps until all cards are properly installed. See [Figure 2-4](#).

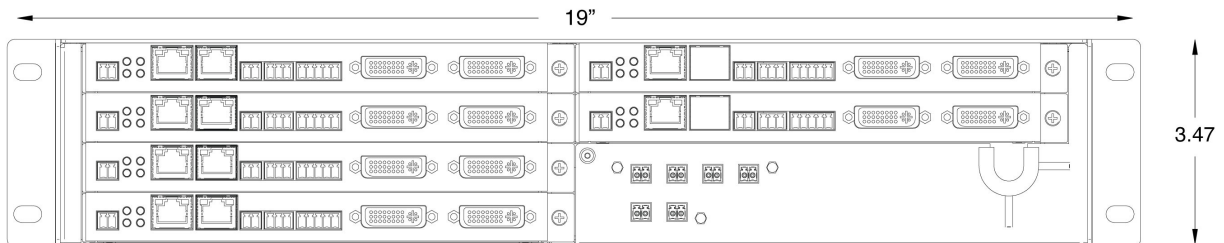

Figure 2-4. Fully-Populated Card Cage

6. For proper airflow, cover any unused card slots with faceplate blanks. Blanks are sold separately (SVSi part number N9210).
7. Make sure the Card Cage's power cord is plugged in for proper cooling.



Caution: Keep the Card Cage's power cord plugged in at all times so that the internal fans are always running. Not doing so could void the warranty of the cage and all installed cards. Fans are not powered while in backup PoE power mode. Please remedy power losses immediately to avoid potential overheating hazards.



Note: Mounting accessories are sold separately and are compatible with most N-Series devices. Contact an SVSi sales representative or visit our website for details.

STEP-BY-STEP INSTALLATION INSTRUCTIONS

This section provides step-by-step guidance for installing and configuring SVSi equipment on your network. The steps provided here assume the following to be true:

1. There are PoE switches operational on the network.

SVSi equipment can operate on many different brands of networking equipment. The network itself needs to meet certain requirements to be able to support an SVSi deployment. These instructions assume that you have purchased and installed a pre-configured switch from SVSi or that your existing equipment meets the following physical and protocol requirements:

- Layer 3, also known as “multi-layer”
- Gigabit Ethernet
- IGMP Snooping
- IGMP Snooping Querier (which only needs to be enabled on a single switch within the network)



Note: To proceed with this installation, the switches must already be successfully connected to your network. If needed, refer to your product’s documentation for installation instructions.

2. Deployment considerations have been made for the addition of high-speed video.

Our Networked AV solutions provide unsurpassed video and audio quality at bandwidths appropriate to any network segment or link. Matrix switches as large as 1200x800 have been constructed on a house network using SVSi’s equipment. Alternatively, many customers choose to deploy on physically separate networks in order to use low-cost network appliances but keep video traffic separate from data and voice.

3. You loaded N-Able onto the computer you are using to configure the equipment.

From your host computer, click this link to download N-Able (SVSi’s free setup utility software) for PC or Mac: <http://svsiav.com/support/resources/software>. This software is designed to set up and control the equipment during initial deployment, however, it is not always the best solution for production-type or primary user control. Refer to [Control Options](#) on page 33 for details on the available control options.

STEP I SETTING UP YOUR HOST COMPUTER

In order to communicate with SVSi equipment, your devices must be on the same subnet as the host computer. N2000 devices are shipped in **Auto IP** mode with a default IP address of 169.254.xxx.xxx. Before beginning installation, you will need to make some changes to the computer running N-Able. These steps show how this can be accomplished in a Microsoft Windows environment.

1. From the **Start** menu, select **Control Panel > Network and Sharing Center**.

2. Select **Change adapter settings**.

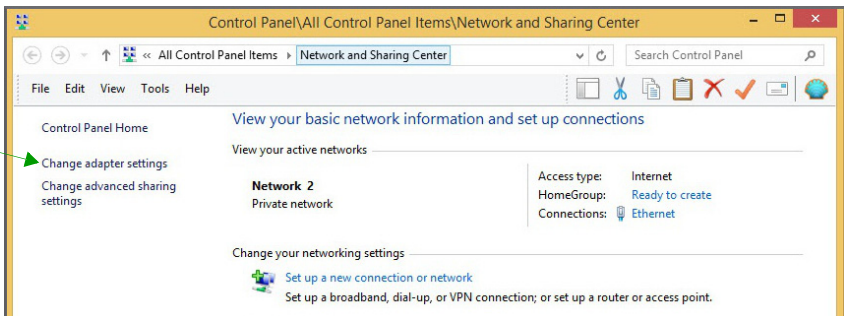

3. Double-click the wired interface to your AV network, and then click the **Properties** button.

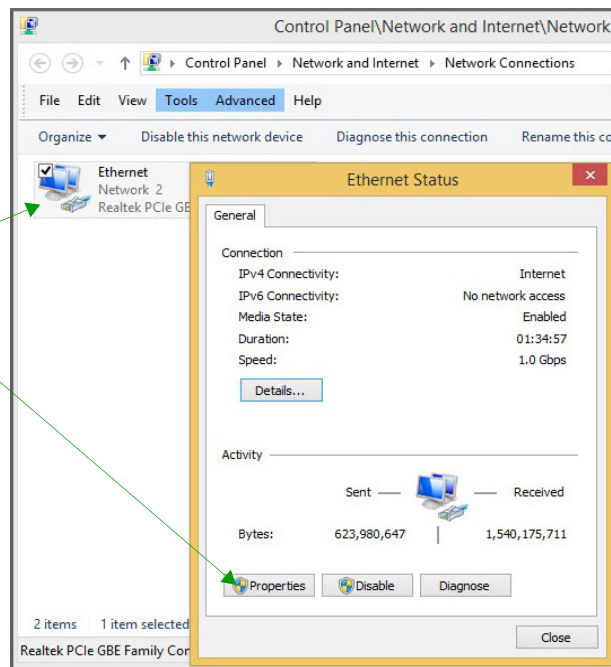

4. Scroll down in the list to the **Internet Protocol Version 4 (TCP/IPv4)** option. Highlight it and click the **Properties** button.

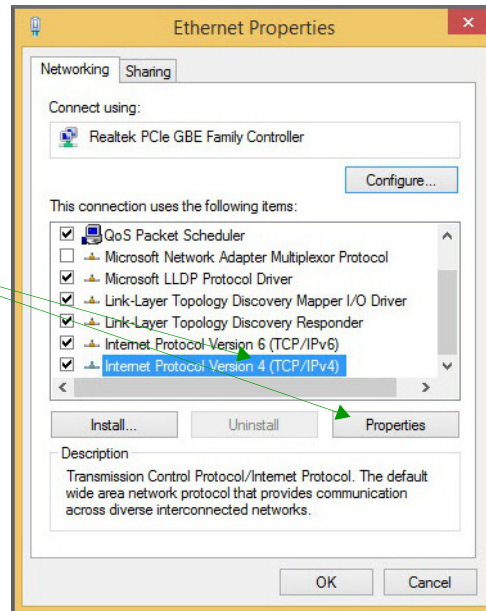

5. Enable the **Use the following IP address** option, and enter the static IP address provided to you by your network administrator.

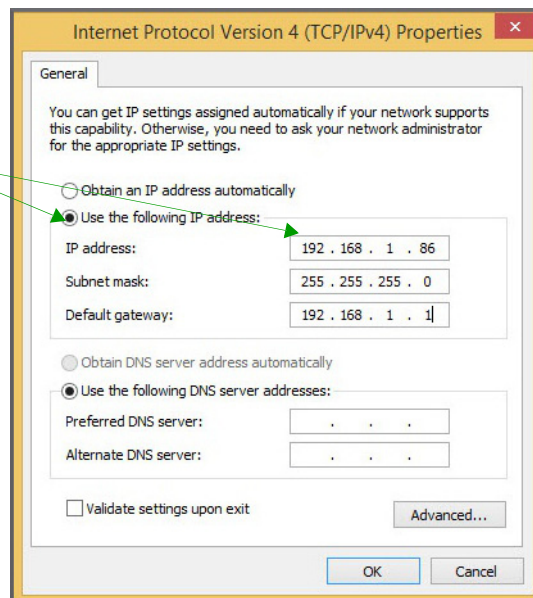

Note: If the computer does not need Internet access, you can simply enter a unique 169.254.xxx.xxx IP address with a 255.255.0.0 subnet mask. Contact your network administrator if you are unsure of how to configure the existing network. SVSi units will not self-assign in the 169.254.0.xxx range.

*Note: If the computer has a statically-assigned IP address, click the **Advanced** button. Then click **Add** to enter a unique 169.254.xxx.xxx address with a subnet of 255.255.0.0.*

STEP 2 CONNECTING DECODERS TO THE NETWORK

The digital connection from a Decoder **DVI-D** port (female) to a display is accomplished using either a DVI-D cable or HDMI (through adapter). N2000 units support embedded audio input and output on the DVI ports; however, some display devices (e.g., many monitors) *do not* support embedded audio. When using such a display, use the **AUDIO** port for separate transmission of sound and turn **HDMI Audio** off (on the **Settings** page) to avoid video display issues.

Power is supplied via a PoE-enabled switch or an external power supply. The N2211 is not a PoE device and must be powered by an external power supply. Refer to the following steps and [Figure 2-5](#) for guidance.

1. Using a Cat-5 cable, connect your SVSi Decoder's **P0** port to a PoE-enabled switch. This provides both network and power connection. In non-PoE applications connect a 12V regulated power supply (N9312) to the two-pin terminal block plug connector (labeled **+12V 2A**).
2. Connect the display you would like to use for that Decoder (monitor, projector, etc.) to the Decoder's **DVI-D Output** port using a DVI cable (or HDMI through adapter). This must be a digital video connection.

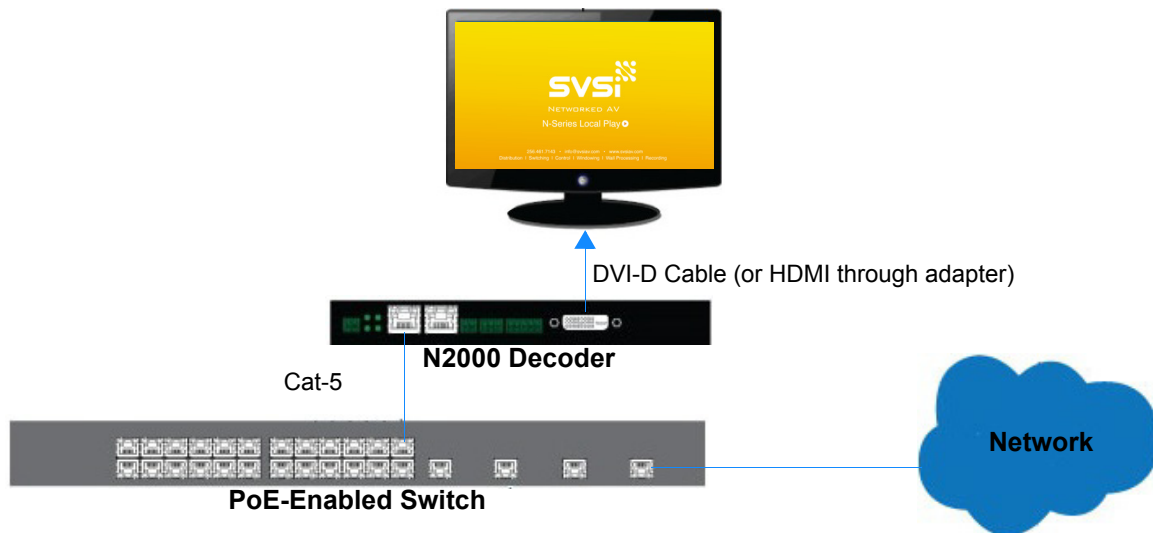

Figure 2-5. Decoder Connections

3. Repeat Steps 1 and 2 until all Decoders are installed on the network.
4. Once the Decoders and displays are connected and powered up, the yellow LocalPlay screen appears on the displays.

*Note: If the yellow LocalPlay screen does not appear, refer to **Chapter 5, Troubleshooting** for more guidance.*



Note: In order for the unit to receive PoE, it must be connected to a switch or other equipment that has a PoE PSE (Power Sourcing Equipment) port. The N2211 Decoder is not a PoE device. When using this product, you must also provide power using the 12V external power supply (included in shipment). PoE does not pass through the daisy chain (P1) port.



Caution: Do not run wiring that is connected to a PoE PSE port outside of the building where the PSE resides. It is for intra-building use only.

STEP 3 CONNECTING ENCODERS TO THE NETWORK AND CONFIGURING STREAM SETTINGS

1. Using a Cat-5 cable, connect your SVSi Encoder's **P0** port to a PoE-enabled switch. In non-PoE applications connect a 12V regulated power supply (N9312) to the two-pin terminal block plug connector (labeled **+12V 2A**).



Note: In order for the unit to receive PoE, it must be connected to a switch or other equipment that has a PoE PSE port.

2. In **N-Able**, select the **Unit Management** tab and click the **Auto Discover** button (if the table has not already populated itself with the installed units). See [Figure 2-6](#).

SVSi N-Able

N-Able Tools StreamCast Help

VIDEO MATRIX AUDIO MATRIX NVR UNIT MANAGEMENT SERIAL MATRIX

Auto Discover Discover by IP You have 1 ENC, 1 DEC, 0 ATR, 0 NVR, 0 WP, and 1 N-Touch. Remove Unit Edit

Search... Clear

	Name	Type	MAC	IP	SN	Streams	Mode	Resolution	Audio
1	00:19:0B:00:1E:5B	N2000 Decoder	00:19:0B:00:1E:5B	169.254.243.238	N222A040001654	434	Live Play	1080p60	On (73)
2	00:19:0B:00:09:0D	N2000 Encoder	00:19:0B:00:09:0D	169.254.247.232	N212A040000112	440	Live Play	720p60	On
3	00:19:0B:00:42:02	N-Touch	00:19:0B:00:42:02	169.254.8.32	N832A010000374				

Figure 2-6. Unit Management Page

3. Find your Encoder in the list. N2000 units are displayed on the following tabs:
 - **Unit Management** tab — N2000 units have **N2000 Encoder/Decoder** listed in their **Type** fields.
 - **Video Matrix** tab — N2000 units are found on the **N2000** sub-tab (as shown in [Figure 2-7](#)).



Note: If using multiple Encoders in your set up, it is important to plug in and configure one Encoder at a time. All Encoders come pre-configured to use stream 1. As you add Encoders to the network, you will need to set them up to use different streams.

Encoders are listed across the top of the page.

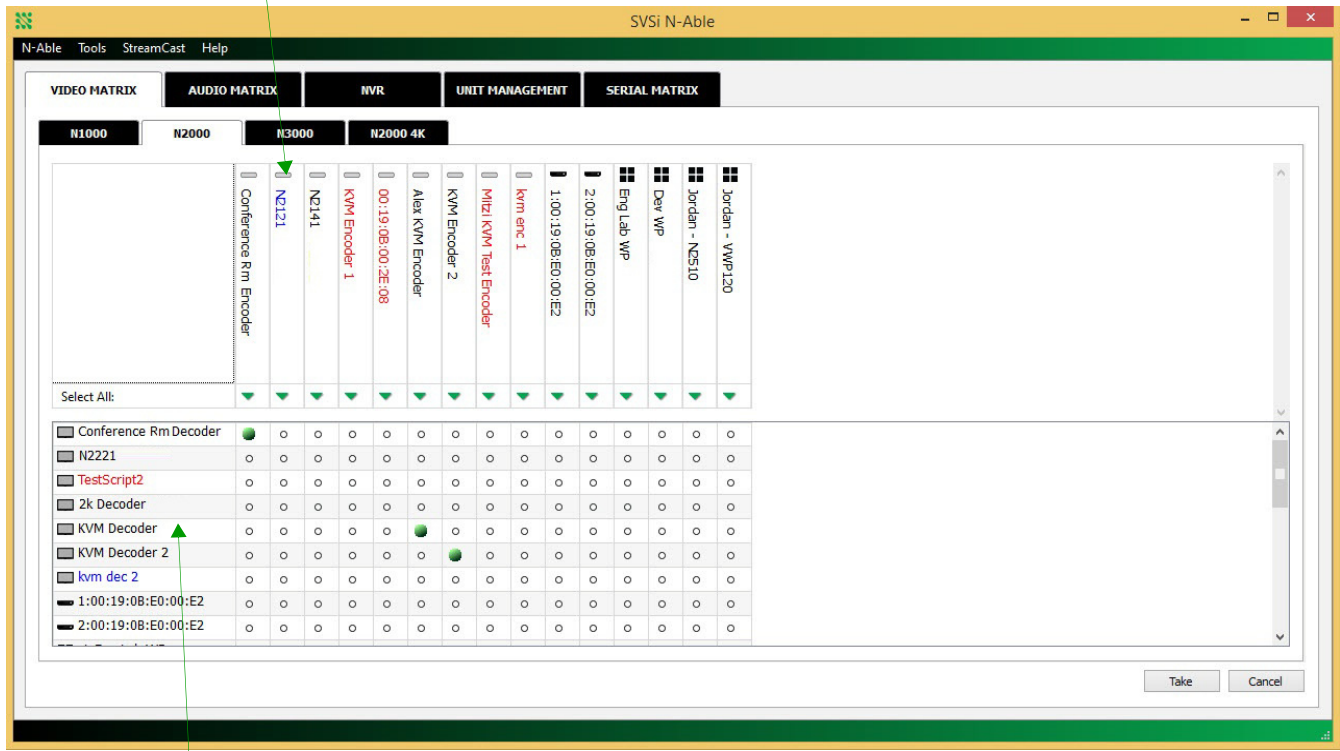

Decoders are listed down the left side of the page.

Red Text - No video source (encoder) or no display (decoder).
 Gray Text - Video output for this unit is disabled.

Black Text - Unit is in live play mode.
Blue Text - Unit is playing locally-stored content.

Figure 2-7. Video Matrix Page

4. Double-click the Encoder's name in the list. The **N-Series Encoder Login** page is displayed (see [Figure 2-8](#)). Use the following default login credentials to log in for the first time. These can be changed later on the **Settings** page.

Default username: **admin**

Default password: **password**

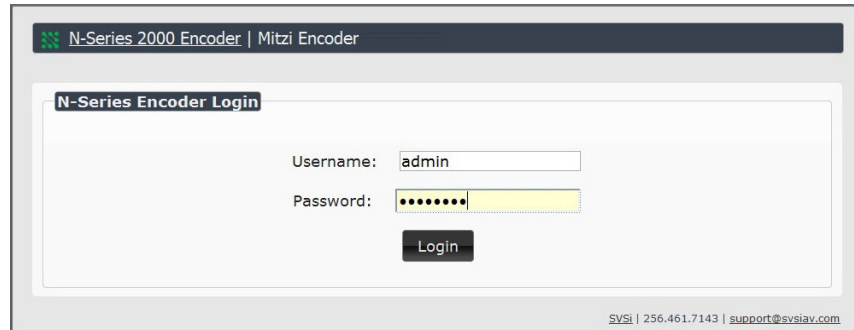

Figure 2-8. Login Page



*The **Login** page is only displayed if N-Able's stored username/password does not match the unit's username/password. A default system will match.*

5. The **Settings** page is displayed (see [Figure 2-9](#)).
6. Change the **Stream** setting. We recommend setting **Stream** to a number between 2 and 254 (it is *required* that the number be less than 32,512).

The screenshot shows the web interface for an N-Series 2000 Encoder, specifically for 'Conference Room Encoder1'. The interface is divided into several sections:

- Encoder Setup:** Contains fields for Device Name (Conference Room Encoder1), TX Enable (checked), Stream (123, highlighted with a green circle), Audio Input Type (Unbalanced), Scaler (checked), Output Mode (720p60), Live/Local (Live), Audio Sample Rate (44100), Extreme Quality (checked), Image Quality (slider), Motion Quality (slider), Mute (unchecked), Enable HDMI Audio (Auto), and Color Space Correction (Auto). Buttons for Cancel and Save are present.
- Network Setup:** Shows IP Mode (STATIC), IP address (169.254.72.159), Netmask (255.255.0.0), and Gateway address (169.254.1.1). A Trial Save button is at the bottom.
- Status:** Displays DVI Status (disconnected), Input Resolution (No Source), DVI Status Pass Thru (disconnected), Current Bandwidth (23.8 Mbps), and source IP addresses for ports 50001, 50002, and Serial Source IP, each with a Flush button.
- Change Password:** A button to change the password.
- Software:** Shows Serial (N212A040000234), MAC address (00:19:0B:00:0B:7B), Web Version (12/15/2014), and Firmware Version (12/15/2014). Buttons for Factory Restore and Reboot are included.
- EDID:** Includes a Show EDID button, Set EDID and Set EDID to Pass-thru buttons, a dropdown menu set to Stereo (2 channel), and a Reset EDID button.
- DVI Pass Thru:** A link to DVI Pass Thru Settings.

At the bottom right of the interface, the text 'SVSI | 256.461.7143 | support@svsiav.com' is visible.

Figure 2-9. Changing Stream Setting

- Repeat these steps until all Encoders are connected to the network and configured with an appropriate **Stream** number.



*Note: Each Encoder's **Stream** number must be unique to all other Encoders on the network.*

*Note: Screen-by-screen descriptions of the web interface options are provided for your reference in **Chapter 3 Encoder Options** and **Chapter 4 Decoder Options**.*

STEP 4 CONFIGURING DECODER AND ENCODER IP ADDRESSES (IF NEEDED)

By default, all Decoders and Encoders are preset to **Auto IP** mode. This means that the IP address is pre-configured to 169.254.xxx.xxx with a subnet mask of 255.255.0.0. When an N2000 is first connected to the network, **Auto IP** checks the network for available IP addresses in the 169.254.xxx.xxx range and then makes an appropriate, static assignment to each unit. It may be beneficial in some applications to use DHCP (Dynamic Host Control Protocol) or static IP addresses, but IP configuration changes must be done correctly to avoid any communication disruptions with the N2000 unit.

How IP Address Changes Affect Unit Control

As discussed previously, N-Able control is dependent upon the host computer being in the same IP address range as the SVSi devices. Therefore, before making any N2000 IP address changes, we recommend having **two statically-assigned IP addresses on your computer**.

- Configure the first IP address to be in the range of the default N-Series IP settings (i.e., in the 169.254.xxx.xxx range), AND
- Configure a second IP address in the range of the IP address you are planning to assign to the units (or when using DHCP, an address within the defined range for your network).

Changing IP Addresses

There are two ways to assign new IP addresses to your N2000 units using N-Able:

- **Option 1:** Log in to each unit individually and make the changes on the **Settings** page.
- **Option 2:** Export a comma-separated value (CSV) file, make changes to all units in the resulting file, and import the CSV file into N-Able to apply the changes.

Option 1: Assigning IP Addresses Individually (using the Settings page)

1. Find the unit you wish to change in the control matrix (either on the **Unit Management** tab or the **Video Matrix > N2000** tab).
2. Double-click the unit and log in.
3. Go to the **Settings** page and make IP address changes for that unit either by setting a **STATIC** address or by enabling **DHCP** (see [Figure 2-10](#)).

Network Setup	
IP Mode:	AUTO IP
IP address	169.254.150.116
Netmask	255.255.0.0
Gateway address	169.254.1.1

Figure 2-10. Network Setup Section of the Settings Page

4. Click the **Trial Save** button.
5. Return to the **Settings** page through the newly-configured IP address.
6. Once the **Settings** page appears (successfully using the new IP address) click the **Confirm** button to lock in your changes.



Note: If you lose communication for any reason, unplug the N2000, wait one minute, and plug it back in. This restores the unit to the original IP address.

Option 2: Assigning IP Addresses to Multiple Units (using CSV files)

N-Able has the ability to export and import CSV files. Once units are auto-discovered in N-Able, the CSV file can be exported into Excel where parameters such as IP address, subnet mask, gateway, stream number, audio settings, etc. can be configured. Once configured, import the CSV file back into N-Able to assign those parameters to the appropriate devices. Reboot the devices to activate the new settings. This procedure can be used to configure multiple networked AV devices at the same time. It can also provide valuable diagnostics by allowing you to see the last known device configuration as well as scan the network for new devices (regardless of IP configuration).

To configure units using a CSV file, follow these steps:

1. Make sure that you have performed an **Auto Discover** (on the **Unit Management** tab of N-Able) since connecting all of the new units to the network.
2. From N-Able's main menu bar, select **N-Able > Export CSV**.
3. Click **Yes** on the pop-up box informing you that a CSV file is about to be generated.



Note: A CSV file editor (e.g., Microsoft Excel) is necessary to proceed.

4. The folder containing your CSV file displays. Double-click the file to open it.
5. You can use this file to edit the IP mode, IP address, subnet mask, gateway IP address, stream number, etc. Once all changes have been made, save the file.
6. Go back into N-Able and select **N-Able > Import CSV**.
7. Browse to your saved CSV file and click **Import**.

STEP 5 CONNECTING ENCODERS TO AN INPUT SOURCE

Having already connected the Encoder(s) to the network and made the appropriate settings changes (as described in [Step 3](#) and [Step 4](#)), you can now connect to the appropriate AV source(s). This connection from an Encoder **DVI-I** port (female) to an input source is accomplished using either a DVI-I cable or HDMI (through adapter).

1. Connect the source you would like to use for the Encoder (camera, laptop, etc.) to the Encoder's **DVI-I Input** port using a DVI-I cable (or HDMI through adapter). This connection can be digital or analog.
2. Repeat until all Encoders are connected to their sources.

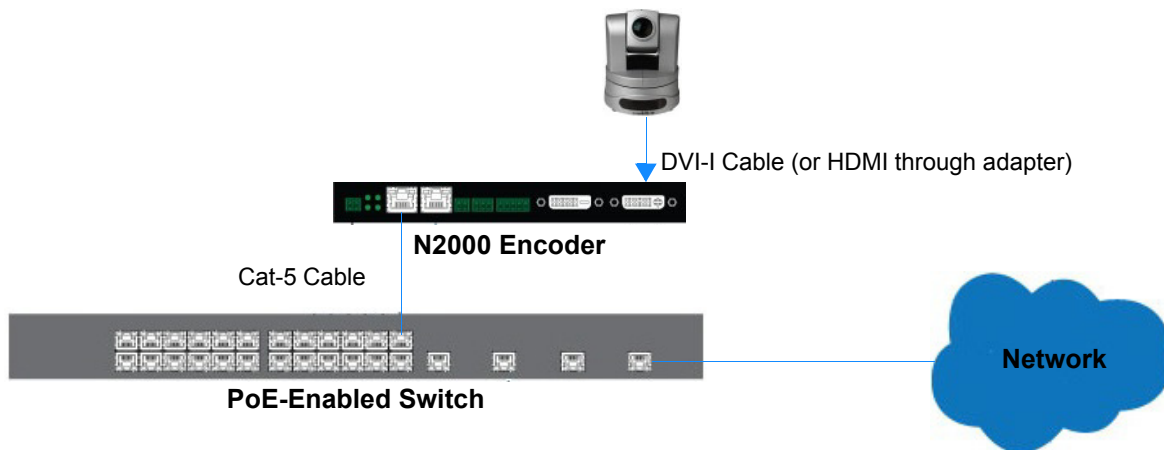

Figure 2-11. Encoder Connection to Source

SWITCHING AND SCALING OPTIONS

SVSi Encoders and Decoders make up a true AV matrix solution. In other words, one input can go to any or all outputs.

Both Encoders and Decoders have internal scaling capabilities. Keep the following in mind:

- The input of an Encoder is the video and/or audio signal going into the Encoder.
- The output of an Encoder is the network stream.
- The input of a Decoder is the network stream.
- The output of a Decoder is the digital video and/or audio being transmitted out to the display device.

Seamless Switching

The N2000 Series supports seamless switching capability if the scalers in the Encoders are all set to the same resolution and refresh rate. If the scalers are off, all of the *sources* must have the same resolution and refresh rate.

To get streams onto a Decoder, use the **Video Matrix** tab to route video from an Encoder to a Decoder. This works seamlessly if the previously mentioned settings are true. All you have to do is click the common cell on the matrix, and click the **Take** button. See [Figure 2-12](#) for an example.

Enabling this cell causes the **Conference Rm Decoder** to listen to the **Conference Rm Encoder**.

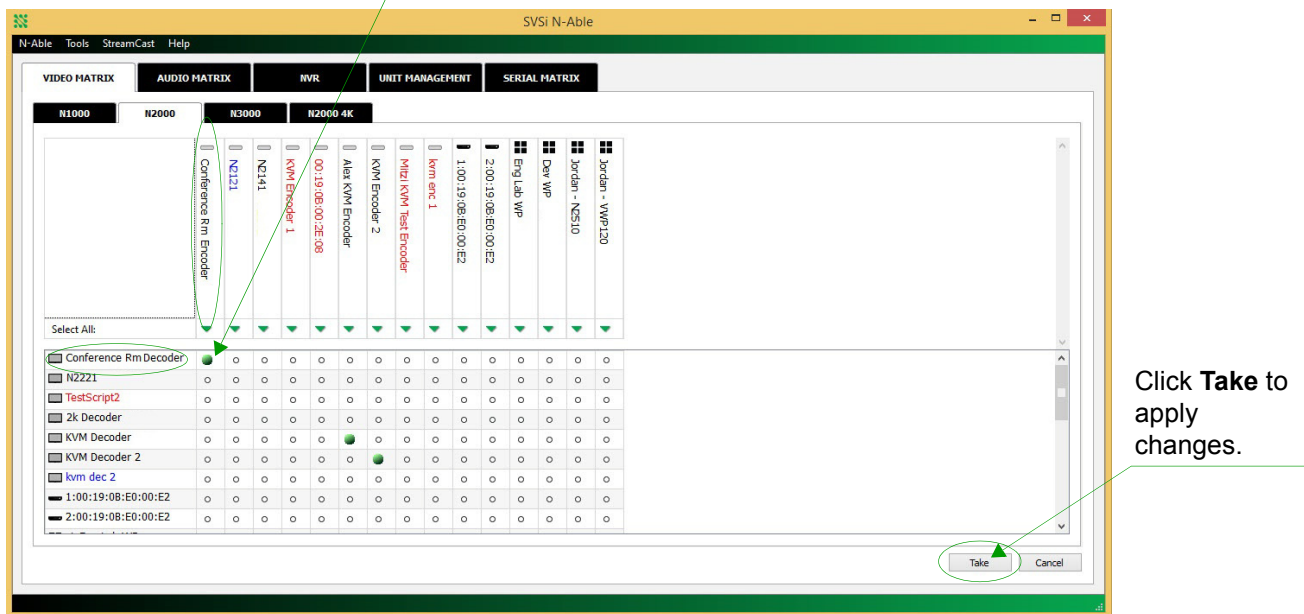

Figure 2-12. Seamless Switching Using the Video Matrix

CONTROL OPTIONS

For the most part, once the initial setup is complete, you will be primarily managing/configuring the Decoders. To better understand, think of Encoders as radio stations and Decoders as car radios. The Encoders are supplying the streams and, using the Decoders, you can “tune in” to the stream you want. SVSi’s N-Control solutions (N-Command, N-Act, and N-Touch) provide you with the most flexible management options available, insuring you are getting the most from your digital media system.

Primary Control Options

During initial configuration and setup, the free N-Able setup utility is sufficient. However, we do not recommend N-Able for production-level, primary-user control.

N-Command Controllers

These web-based hardware Controllers offer intuitive, powerful management of equipment, content, NVR recording/playback, bandwidth utilization, and AV switching (using a web-based, point-and-click graphical matrix).

The N-Command product line also offers:

- Simplified ASCII interface for third-party control via TCP/IP.
- Enterprise controller (N8012) has master/client failover protection and hot-swappable drives.
- Redundant power supplies.
- Graphical presentation of video network connections.
- Full configuration control: assign fixed IP addresses for each SVSi component, adjust variable bit-rate for each video stream, etc.

Visit our website and refer to [Table 2-2](#) on page 35 for more details on the available N-Command Controllers.

Third-Party Controllers

The N2000 Series is capable of interfacing with third-party control systems such as Savant, Utelogy, AMX, Altinex, or Crestron. SVSi can provide Crestron modules which allow either direct control of each Encoder and Decoder or relayed commands through an N-Command controller. Contact SVSi support for third-party control modules.

Other Control Options

SVSi offers several simple solutions for convenient one touch (or no touch) device control. This includes touch panel as well as event-based commands used for controlling both SVSi products and third-party equipment.

N-Act | On-Board, Built-In Control

All N-Series Encoders and Decoders have on-board, built-in control capability via events that can trigger any number of TCP/UDP commands to other IP controllable devices. Included free with all N-Series Encoders/Decoders. See the section [N-Act Page](#) on page 61 for more information.

N-Touch | IP Wall Controller

This 240 x 320 capacitive touch display has Wi-Fi and Bluetooth for expanding control to mobile devices. Programming is done individually through the built-in web server or collectively to multiple units using an N-Command N8000 Series Controller. Multi-page custom graphics can be created using SVSi’s free Panel Builder software (stored internally).

Software Bundles Included With N-Command

- **Panel Builder:** Build attractive touch panels to control the N2000 and third-party equipment.
- **Wall Builder:** Design walls of any size in minutes using SVSi's Encoders and Decoders.

Table 2-2. Management Options for the N2000 Series

Features	N-Able Control Software	N-Touch Controller	N8001 Controller	N8002 Controller	N8012 Controller
Web-based Control		✓	✓	✓	✓
Group Management			✓	✓	✓
Third-party Control		✓	✓	✓	✓
Remote web-based Diagnostics			✓	✓	✓
Software Installation Not Required		✓	✓	✓	✓
Virtual Matrix Switching	✓		✓	✓	✓
Touch-panel editing and hosting		✓	✓	✓	✓
Mobile devices supported		✓	✓	✓	✓
Panel Builder		✓	✓	✓	✓
Scripts		✓	✓	✓	✓
Interface to Networked AV system	Host Network Interface	Network	Network	Dual Network Interfaces	Dual Network Interfaces
Redundant power supplies					✓
Fail-over support					✓
1-yr Priority Help subscription					✓
Max Number of Users	1	Unlimited	5	Unlimited	Unlimited
Max Number of Devices	Unlimited	Unlimited	50	Unlimited	Unlimited

Chapter 3

ENCODER OPTIONS

ENCODER INTRODUCTION

This chapter defines all of the configuration options available on your N2000 Series Encoders and is organized to reflect the graphical user interface (GUI) for ease of navigation.

ENCODER CONFIGURATION OPTIONS

From any main page in the internal web interface, you can access all other main pages by clicking the links in the top navigation bar. [Figure 3-1](#) shows the main navigation bar and provides hot links to the sections of this chapter which describe them.

[Settings Page](#) on page 37.

[Crop/Pan/Zoom Page](#) on page 56.

[HostPlay Page](#) on page 58.

[IR Page](#) on page 60.

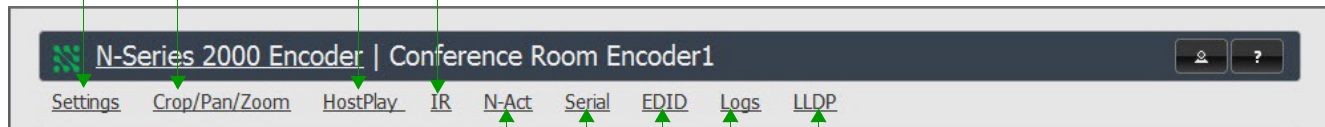

[N-Act Page](#) on page 61.

[Serial Page](#) on page 63.

[EDID Page](#) on page 65.

[Logs Page](#) on page 66.

[LLDP Page](#) on page 67.

Figure 3-1. Section Links

SETTINGS PAGE

Click the **Settings** link at the top of any of the main web pages to access the page shown in [Figure 3-2](#). This page is divided into several sections and also has links to other dialog boxes for additional configuration options. Refer to the following sections for detailed descriptions:

- [Encoder Setup Section](#) on page 38
- [Advanced Settings](#) on page 42
- [RS232 Settings](#) on page 46
- [Network Setup Section](#) on page 47
- [Status Section](#) on page 49
- [Change Password](#) on page 51
- [Software Section](#) on page 52
- [EDID Section](#) on page 53
- [DVI Pass Thru Settings](#) on page 55

N-Series 2000 Encoder | Conference Room Encoder1

Settings Crop/Pan/Zoom HostPlay IR N-Act Serial EDID Logs LLDP

Encoder Setup

Device Name: Conference Room Encoder1

TX Enable Enable

Stream 123

Audio Input Type Unbalanced

Scaler Enable

Output Mode 720p60

Live/Local Live

Audio Sample Rate 44100

Extreme Quality Enable

Image Quality

Motion Quality

Mute Mute

Enable HDMI Audio Auto (is off)

Color Space Correction Auto

Cancel Save

Network Setup

IP Mode: STATIC STATIC

IP address 169.254.72.159 169.254.72.159

Netmask 255.255.0.0 255.255.0.0

Gateway address 169.254.1.1 169.254.1.1

Trial Save

Status

DVI Status: disconnected

Input Resolution: No Source

DVI Status Pass Thru: disconnected

Current Bandwidth: 23.8 Mbps

Port 50001 Source IP: Disconnected Flush

Port 50002 Source IP: Disconnected Flush

Serial Source IP: Disconnected Flush

Change Password

Change Password

Software

Serial: N212A040000234

MAC address 00:19:0B:00:0B:7B

Web Version: 12/15/2014

Firmware Version: 12/15/2014

Factory Restore Reboot

EDID

Show EDID

Set EDID Set EDID to Pass-thru

Stereo (2 channel) Reset EDID

DVI Pass Thru

DVI Pass Thru Settings

SVSI | 256.461.7143 | support@svsiav.com

Figure 3-2. Settings Page

Encoder Setup Section

The **Encoder Setup** section of the **Settings** page is shown in [Figure 3-3](#). Options are described in [Table 3-1](#).

Encoder Setup

Device Name:

TX Enable Enable

Stream

Audio Input Type

Scaler Enable

Output Mode

Live/Local

Audio Sample Rate

Extreme Quality Enable

Image Quality

Motion Quality

Mute Mute

Enable HDMI Audio (is off)

Color Space Correction

[Advanced Settings](#)

[RS232 Settings](#)

Allow SVSi Multicast P0 P1

Disable P1 Disable

Figure 3-3. Encoder Setup Section

Table 3-1. Settings Page: Encoder Setup Section

Option	Description	Notes
Device Name	Enter a user-friendly name for the unit.	More descriptive names in this field help you organize and manage the SVSi system efficiently. Names based on the unit's location and function are very useful. Some good examples are Lobby-Left-VGA (for left side of lobby, VGA input) or CR201-HDMI (for Conference Room 201, HDMI input). Keep in mind the matrices are organized alphanumerically.
TX Enable	Enable to broadcast the AV signals. Disable to turn off/stop broadcasting.	Unit name appears in GREY text (in the Matrix) when this setting is disabled.
Stream	View/edit the current transmit stream number.	To better understand this setting, think of Encoders more like a channel on a cable box, rather than a traditional AV Matrix. Each Encoder must have a unique stream number, just like every channel must have a unique channel number (e.g., Food Network and HGTV cannot both be on channel 201).
Audio Input Type	Select Unbalanced (single-ended) or Balanced analog audio input.	
Scaler	Enable to scale outgoing content to a fixed resolution or to use the Crop/Pan/Zoom functions.	
Output Mode	Select the output resolution of the video to be transmitted onto the network (the Scaler check box must be enabled for this to be applicable).	
Live/Local	Select live video or locally stored images for transmission onto the network. When video is not available, it automatically goes into local mode.	When video is not available, the most recently played local playlist is displayed.
Audio Sample Rate	Select the sample rate, in Hz, for the analog audio.	

Table 3-1. Settings Page: Encoder Setup Section (Continued)

Option	Description	Notes
Extreme Quality	Enable this check box to achieve best possible picture quality.	Enabling this option will increase your bandwidth, up to 200 Mbps per stream. Plan bandwidth accordingly. Enabling this option increases video quality only in situations where there are dense lines or dramatic color variations (e.g., a dense map or fully-populated spreadsheet). Can be disabled for most applications.
Image Quality	Adjust the compression level of the image. The further to the left on the slider, the more compression which will display as pixelization of the image.	When Extreme Quality is enabled, this slider's settings are not applied.
Motion Quality	Adjust the frame rate reduction. All the way to the right of the slider is 60 frames. As you slide left, you reduce frame rates.	The quickest way to reduce overall bandwidth is to reduce motion quality. However, this increases latency.
Mute	Enable to stop the transmission of audio data onto the network.	
Audio Source	Set the audio source to be disabled, enabled or selected automatically (see note).	The AUTO setting always corresponds to HDMI audio as long as there is an HDMI source. If the source is unplugged, it will automatically fall back to analog audio (if there is an analog source plugged in).
Color Space Correction	Set the color space settings for the Encoder (YcbCr, RGB) to be disabled, enabled, or selected automatically based on the source.	If you see a pink/green washed out screen (across the entire image), this can be changed by modifying color space settings. Most sources function with Auto selected but (for problematic sources) hard-set the value to what the source requires. It is best to do hard-set for all permanently installed sources (e.g., cameras, cable boxes, etc), but leave Auto on for periodic sources (e.g., laptop inputs).
Advanced Settings	Refer to Advanced Settings on page 42 for details on the options available from this link.	
RS232 Settings	Refer to RS232 Settings on page 46 for details on the options available from this link.	

Table 3-1. Settings Page: Encoder Setup Section (Continued)

Option	Description	Notes
Allow SVSi Multicast	Disable this option to prevent the port from outputting multicast video traffic.	Particularly useful if you are connecting a non-SVSi device to a port for network-based control.
Disable P1	Completely disables the P1 port for all traffic.	Once disabled, anything connected to the P1 port will no longer be available on the network.
Cancel	Click to return all controls to the last saved configuration.	
Save	Click to accept changes made to these controls.	

Advanced Settings

The section of the **Settings** page shown in [Figure 3-4](#) is displayed when you click the **Advanced Settings** link. Options are described in [Table 3-2](#).

Advanced Settings

Settings Lock	<input type="checkbox"/> Enable
Input Level Gain Left	0
Input Level Gain Right	0
Audio Gain	<input type="range"/>
Audio Gain Left	<input type="range"/>
Audio Gain Right	<input type="range"/>
Brightness	<input type="range"/>
Horz Offset	0
Vert Offset	0
Gen1 Output Mode	<input type="checkbox"/> Enable
Component Sync Window	<input type="range"/>
Input audio for LocalPlay	<input type="checkbox"/> Enable
HostPlay for Unsupported	<input type="checkbox"/> Enable
Gratuitous ARP	<input type="checkbox"/> Enable
ARP Interval(secs)	50
Unsolicited Status	<input checked="" type="checkbox"/> Enable
Send Status Address	169.254.10.38
Status Interval(secs)	10
Discovery Packet Transmit	<input checked="" type="checkbox"/> Enable
Discovery Interval(secs)	10
TTL	64
VLAN Tagging	<input type="checkbox"/> Enable
VLAN #	0
DSCP #	88
Serial Master Enable	<input type="checkbox"/> Enable
Serial Slave Address	0.0.0.0
IR Command Holdoff	25 ms <input type="button" value="↺"/>
IR Repeat Holdoff	90 ms <input type="button" value="↺"/>
Maintain Aspect Ratio	<input checked="" type="checkbox"/> Enable
Enable SNMP	<input type="checkbox"/> Enable

Figure 3-4. Advanced Settings

Table 3-2. Settings Page: Advanced Settings

Option	Description	Notes
Settings Lock	Enable to lock the Encoder IP settings and stream number, preventing automated processes (from N-Able or N-Command) from occurring.	This does <i>not</i> prevent a control system from making changes or a user from manually making changes.
Input Level Gain Left/Right	Select a PRE-ENCODE cut in the audio signal.	This can help prevent distortion of the audio when the source is providing audio that is too loud/clipping. Setting does <i>not</i> affect digital audio.
Audio Gain	Slide right to provide a POST-ENCODE boost in the audio signal (to both left and right channel).	This can help compensate when the source is providing a weak audio signal. Does not affect digital audio.
Audio Gain Left	Slide right to provide a POST-ENCODE boost in the left channel's audio signal.	This can help compensate when the source is providing a weak audio signal. Does not affect digital audio.
Audio Gain Right	Slide right to provide a POST-ENCODE boost in the right channel's audio signal.	This can help compensate when the source is providing a weak audio signal. Does not affect digital audio.
Brightness	Use sliders to raise or lower RGB values of the Encoder (POST-ENCODE).	Only affects analog video. Does not affect digital video.
Horz Offset	Enter the number of pixels to shift the screen to the left. Range is -4 to 4 pixels.	The higher the number, the more to the left the screen will shift. <i>Enter even numbers only</i> to prevent red/blue color swapping.
Vert Offset	Enter the number of pixels to shift the screen up and down. Range is -100 to 100 pixels.	The higher the number, the higher the screen will shift.
Gen1 Output Mode	Enable when outputting to V-Series decoders.	
Component Sync Window	Use this slider to configure the sync on green sensitivity.	Used for computer video input to help with screen flickering.
Input audio for HostPlay	Enable to activate the input audio when the Live/Local menu is set to one of the local images.	
HostPlay for Unsupported	Enable to cause the Encoder to use a custom image whenever an unsupported video mode is supplied to it.	

Table 3-2. Settings Page: Advanced Settings (Continued)

Option	Description	Notes
Gratuitous ARP	Enable the Encoder to send a periodic Address Resolution Protocol (ARP) packet to the network.	
ARP Interval (secs)	Determine how often (in seconds) the unit transmits gratuitous ARP packets.	
Unsolicited Status	Enable the Encoder to send a periodic status packet to the Send Status Address described below.	
Send Status Address	When Unsolicited Status is enabled, the Encoder sends a periodic status packet to the IP address specified here.	
Status Interval (secs)	Determine how often (in seconds) the unit transmits status packets.	
Discovery Packet Transmit	Enable the SVSi multicast discovery service (which is used to identify units).	This is useful for larger network integrations when broadcast packets will not cover the entire network. Enabled by default.
Discovery Interval (secs)	Determine how often (in seconds) the unit transmits discovery packets.	
TTL	Select the Time To Live (TTL) for the transmit audio and video streams.	Limits the lifespan of data on the transmit audio and video streams (to improve performance).
VLAN Tagging	When enabled, tags the video and audio IP packet with the VLAN number.	
VLAN #	Enter the VLAN number.	This number will be included in the video and audio IP packet when VLAN Tagging is enabled.
DSCP #	Select the Differentiated Services Code Point (DSCP) for the transmit audio and video streams.	
Serial Master Enable	Enable this device to be the master to the designated client.	
Serial Client Address	Enter the IP address of the serial client device.	

Table 3-2. Settings Page: Advanced Settings (Continued)

Option	Description	Notes
IR Command Holdoff	Set the delay between IR command portions. The default setting is 25 ms.	IR commands are sent in two parts. This setting is the time (in milliseconds) between transmission of part one and part two. The second part of the command is inverted for confirmation purposes.
IR Repeat Holdoff	Set the repeat delay between IR commands. The default setting is 90 ms.	This is the amount of time before a new command is sent. For example, when pressing and holding the volume button on a remote control, this is how long until the command is repeated.
Maintain Aspect Ratio	When scalers are enabled, enabling this check box maintains the source's aspect ratio.	
Enable SNMP	Enable to allow the device to handle Simple Network Management Protocol (SNMP) queries.	

RS232 Settings

The section of the **Settings** page shown in [Figure 3-5](#) is displayed when you click the **RS232 Settings** link. Options are described in [Table 3-3](#).

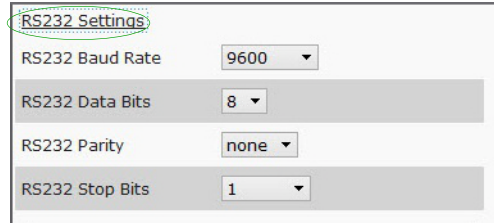

The screenshot shows a form titled "RS232 Settings" with four rows of configuration options, each with a dropdown menu:

- RS232 Baud Rate: 9600
- RS232 Data Bits: 8
- RS232 Parity: none
- RS232 Stop Bits: 1

Figure 3-5. RS232 Settings

Table 3-3. Settings Page: RS232 Settings

Option	Description
RS232 Baud Rate	Select the appropriate baud rate for the RS232 serial interface. Default is 9600.
RS232 Data Bits	Select the appropriate data bit count for the RS232 serial interface. Default is 8.
RS232 Parity	Select the appropriate parity for the RS232 serial interface. Default is no parity (none).
RS232 Stop Bits	Select the appropriate number of stop bits for the RS232 serial interface. Default is 1.

Network Setup Section

The **Network Setup** section of the **Settings** page is shown in [Figure 3-6](#). Options are described in [Table 3-4](#).

The screenshot shows a 'Network Setup' form with the following fields and values:

- IP Mode:** STATIC (selected in a dropdown menu)
- IP address:** 169.254.72.159
- Netmask:** 255.255.0.0
- Gateway address:** 169.254.1.1

A 'Save' button is located at the bottom right of the form.

Figure 3-6. Network Setup Section

Table 3-4. Settings Page: Network Setup Section

Option	Description	Notes
IP Mode	Configure the IP address mode. When set to AUTO IP , an IP Address in the range of 169.254.xxx.xxx with Netmask of 255.255.0.0 and Gateway address of 169.254.1.1 will be automatically assigned to the N2000 Encoder by the control software. When set to DHCP , an IP Address in the range of the DHCP server on the network will be automatically assigned to the N2000 Encoder. When set to STATIC , an IP address , Netmask , and Gateway address must be manually entered.	Using DHCP is generally not recommended. If the device is set to DHCP and fails to receive an address from the DHCP server in time, it will revert back to the AUTO IP Address (169.254.xxx.xxx) until the unit is rebooted.
IP address	View the current IP address of the N2000 Encoder. When in STATIC mode, enter a new IP address into this field.	
Netmask	View the current Netmask of the N2000 Encoder. When in STATIC mode, enter a new Netmask into this field.	
Gateway address	View the current Gateway address of the N2000 Encoder. When in STATIC mode, enter a new Gateway address into this field.	

Table 3-4. Settings Page: Network Setup Section (Continued)

Option	Description	Notes
Trial Save	Click to initially save IP address changes. Once you log in to the unit using the new address, you will be able to confirm and accept the changes permanently.	

Status Section

The **Status** section of the **Settings** page is shown in [Figure 3-7](#). Options are described in [Table 3-5](#).

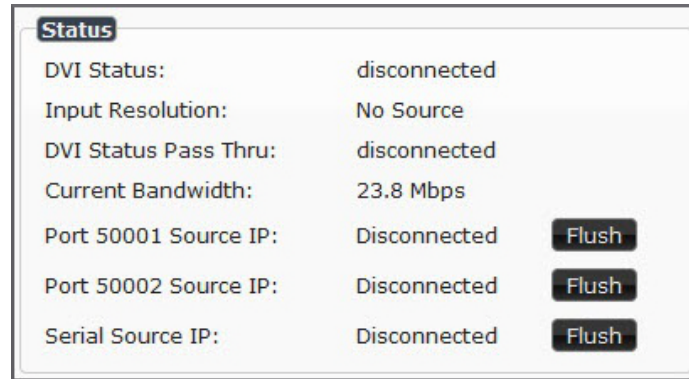

Figure 3-7. Status Section

Table 3-5. Settings Page: Status Section

Option	Description	Notes
DVI Status	Indicates if a video source is connected to the Encoder.	
Input Resolution	Indicates the video resolution of the currently connected source.	
DVI Status Pass Thru	Indicates if a display device is connected to the Encoder.	
Current Bandwidth	This is a snapshot of the unit as properties were loaded to the browser, not a live counter. Refresh the page to get an updated bandwidth.	
Port 50001 Source IP	Shows the IP address of the currently connected device or displays Disconnected if no connection exists.	Port 50001 can only accept a single external connection at a time. If a device is currently showing the port occupied (by a control system or other device), then other connections will be rejected. However, connection attempts from the same IP will override the current connection.

Table 3-5. Settings Page: Status Section (Continued)

Option	Description	Notes
Port 50002 Source IP	Shows the IP address of the currently connected device or displays Disconnected if no connection exists.	Port 50002 can only accept a single external connection at a time. If a device is currently showing the port occupied (by a control system or other device), then other connections will be rejected. However, connection attempts from the same IP will override the current connection.
Serial Source IP	Shows the IP address of the currently connected device or displays Disconnected if no connection exists.	Only a single external connection can be accepted on the port. If a device is currently showing the port occupied (by a control system or other device), then other connections will be rejected. However, connection attempts from the same IP will override the current connection.
Flush buttons	These buttons reset the port.	

Change Password

To change the N2000 Encoder interface password, enter the current password in the field labeled **Old Password**, and enter a new password in the **New Password** and **Confirm Password** fields. Click **Change PW** to accept the new password.

A screenshot of a web form titled "Change Password". The form has a title bar with "Change Password" and a close button. Below the title bar, there is a link that says "Change Password". The form contains three input fields: "Old Password:", "New Password:", and "Confirm Password:". To the right of the "Confirm Password:" field is a button labeled "Change PW".

Figure 3-8. Change Password



This password needs to match N-Able's stored password to allow auto-login using N-Able.

Software Section

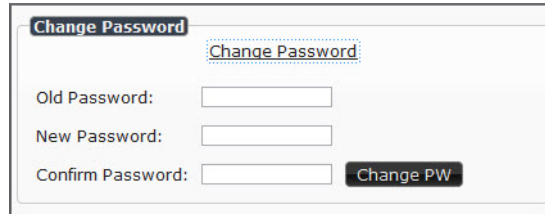
The **Software** section of the **Settings** page is shown in [Figure 3-9](#). Options are described in [Table 3-6](#).



Figure 3-9. Software Section

Table 3-6. Settings Page: Software Section

Option	Description
Serial	Displays the serial number of the N2000 Encoder.
MAC Address	Displays the MAC address of the network interface of the N2000 Encoder.
Firmware Version	Displays the date code for the currently running version of the N2000 Encoder internal firmware.
Web Version	Displays the date code for the currently running version of the web interface.
Factory Restore	Click to restore the device to the original factory settings. This resets everything except the IP address (including name, stream number, serial settings, etc.).
Reboot	Click to reboot the device (does not affect current configuration).

EDID Section

The **EDID** (Extended Display ID Data) section of the **Settings** page is shown in [Figure 3-10](#). Options are described in [Table 3-7](#).

Edit the Encoder's EDID if you need to change the device type it appears as to the source. There are two different ways to control the EDID of the Encoders.

Option 1: Use the default settings drop-down menu and select from the options available. Then click **Reset EDID**. This will work for most sources and is most often set to **Stereo (2 channel)**.

Option 2: When using an EDID captured from a source connected to an Encoder, paste the data in to the white EDID block, overwriting existing EDID. Then click **Set EDID**.



The source will need to be disconnected while modifying EDID settings.

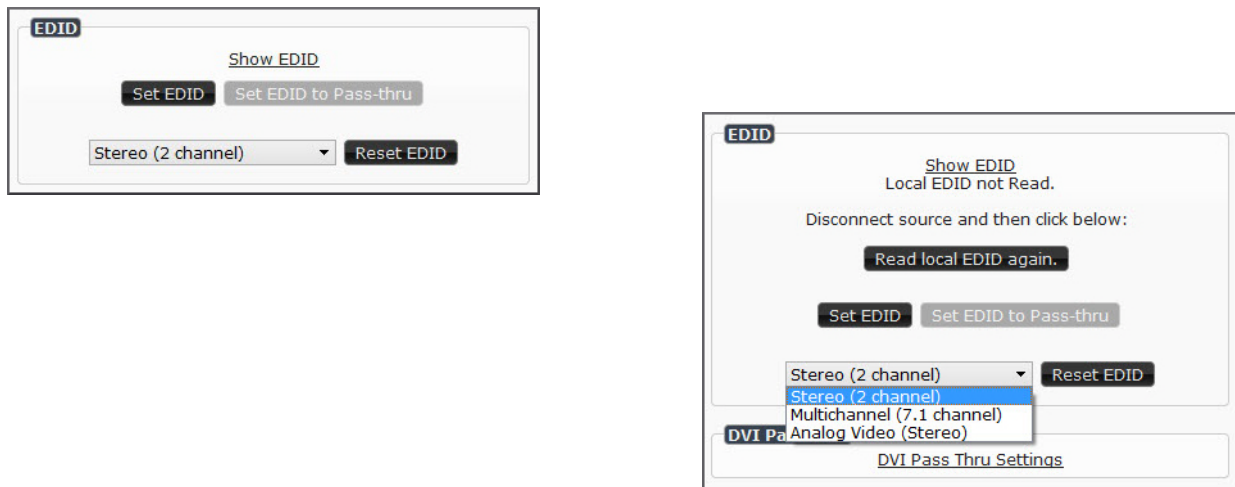

Figure 3-10. EDID Section

Table 3-7. Settings Page: EDID Section

Option	Description
Show EDID	Click this link to view the Encoder's current EDID table.
Read local EDID	Click if source EDID has changed (refreshes the EDID table).
Set EDID	If pasting a custom EDID, click to apply the changes.

Table 3-7. Settings Page: EDID Section (Continued)

Option	Description
Set EDID Pass-thru	Set if you want to copy the current EDID to the Encoder's pass thru port.
Reset EDID	Choose a standard EDID from the drop-down menu and click Reset EDID to apply.

DVI Pass Thru Settings

The section of the **Settings** page show in [Figure 3-11](#) is displayed when you click the **DVI Pass Thru Settings** link. Options are described in [Table 3-8](#).

Figure 3-11. DVI Pass Thru Settings

Table 3-8. Settings Page: DVI Pass Thru Settings

Option	Description
DVI Pass Thru	Enables looped output.
Enable HDMI Audio	Determines if the unit will output audio over the HDMI connection. Selecting Auto bases audio output on the settings of the connected source device.
YCbCr 4:2:2 Output	For color conversion. Can force to RGB on set output based on connected device's reported settings. Default (and preferred setting) is Off .
Simplified DVI Detect	When enabled, detects DVI solely based on the hot plug detection. Enable to help prevent displays/monitors from going to sleep.
Invert DVI Sync	Inverts horizontal and vertical synchronization to the output display. Used for non-standard displays.
Cancel	Click to return all controls to the last saved configuration.
Save	Click to accept changes made to these controls.

CROP/PAN/ZOOM PAGE

Click the **Crop/Pan/Zoom** link at the top of any of the main web pages to access the page shown in [Figure 3-12](#). This page allows you to customize the viewable portion of the input. See [Table 3-9](#) for option descriptions.

Figure 3-12. Crop/Pan/Zoom Page



*Note: The **Scaler** check box must be enabled for changes on this page to take effect. See [Table 3-1](#) on page 39 for more information.*

Table 3-9. Crop/Pan/Zoom Page Options

Option	Description
X1, Y1	Set pixel coordinates of viewing area (top left).
X2, Y2	Set pixel coordinates of viewing area (bottom right).
16:9 Aspect Ratio	Enable to force to a 16:9 ratio.
No Crop	Click to disable existing crop settings and return unit to default output settings.
Execute Crop Reference	Click to execute changes.
Save Crop Reference	Click to save the current settings and store them as a preset for later use. Presets can be used by third-party controllers.
Stored Crop Presets	Use this section of the page to select/delete/export/import cropping presets.

HOSTPLAY PAGE

Click the **HostPlay** link at the top of any of the main web pages to access the page shown in [Figure 3-13](#). This page allows you to upload new images to the Encoders and configure the image playlists. The playlist will be shown on the display when no video is being transmitted or received. You can show a single image or set up multiple images to be displayed at a customized animation rate. See [Table 3-10](#) for option descriptions.

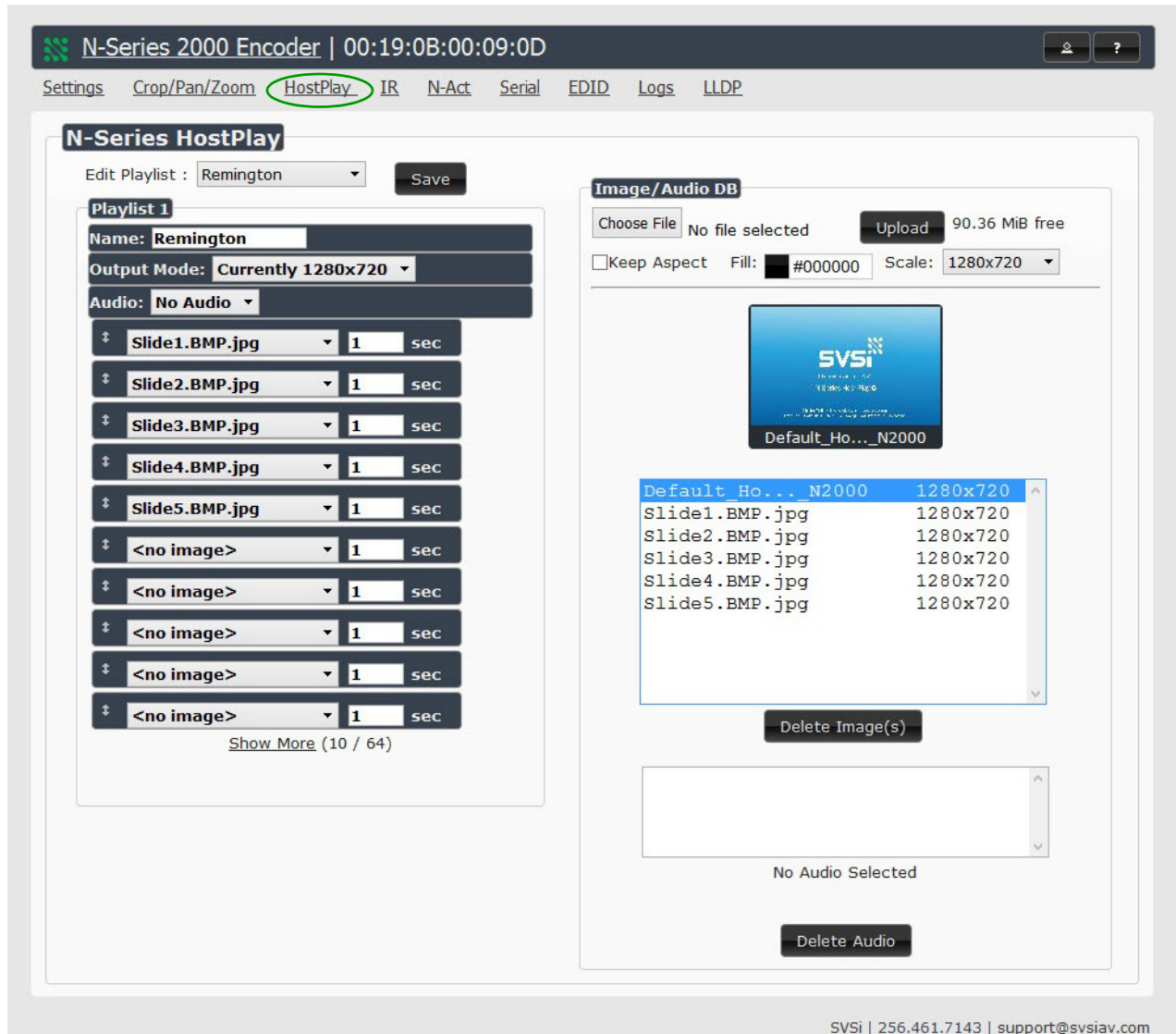

Figure 3-13. HostPlay Page

Table 3-10. HostPlay Page Options

Option	Description
Edit Playlist	Select a playlist from the drop-down menu to view/edit the images currently used in the chosen image playlists. If more than one image appears in the list, a transition time can be set for each image.
Save	Click to save the current configuration.
Name	Enter a name for the playlist.
Output Mode	Select the HostPlay output resolution. The playlists that were uploaded in that resolution are then displayed for your selection.
Audio	Choose an audio file to play while the HostPlay image is on the screen.
Image list	Allows you to customize what images are displayed, the transition time for each image, etc.
Image/Audio DB	This section provides the ability to upload image and audio files to the N2000 Encoder database. You can also use the Fill field to customize the background color (used behind HostPlay images that do not take up the entire screen).
Delete Images	Delete the selected image file from the playlist.
Delete Audio	Delete the selected audio file from the playlist.

IR PAGE

Click the **IR** link at the top of any of the main web pages to access the page shown in [Figure 3-14](#). This page allows you to upload and execute IR Pronto codes so that other vendor's devices can be controlled through the Encoder's IR connector. Commands can be saved for future use and executed later. The **IR Code** menu lists all saved IR commands. See [Table 3-11](#) for option descriptions.

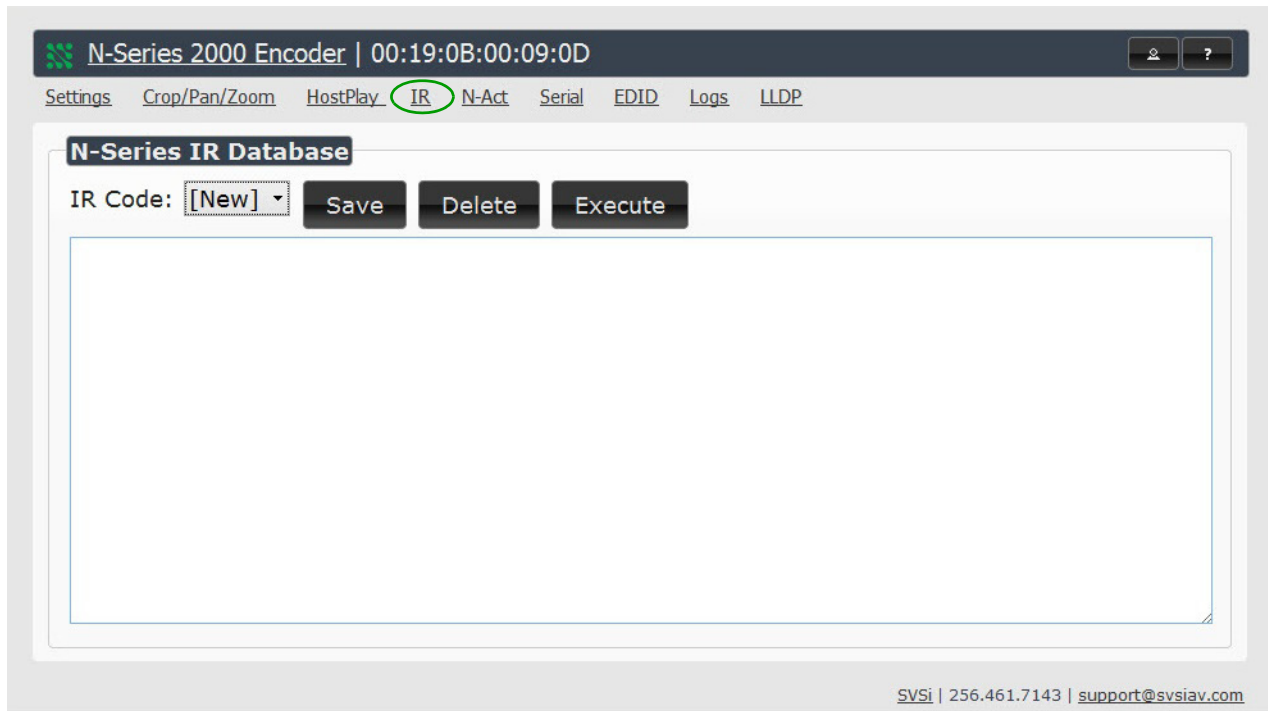

Figure 3-14. IR Page

Table 3-11. IR Page Options

Option	Description
IR Code	Create/select IR codes. Different vendors have different IR Pronto codes and can usually be found through a web search. Copy/paste new IR commands directly into the input space.
Save	Save the current code.
Delete	Delete the current code.
Execute	Activate the selected code through the Encoder's IR connector.

N-ACT PAGE

Click the **N-Act** link at the top of any of the main web pages to access the page shown in [Figure 3-15](#). This page allows you to create command lists which are performed automatically by the unit based on power or video connection (without the use of an outside controller). For example, you can tell a projector and lights to come on when the Encoder powers up. You can add multiple commands for each event. See [Table 3-12](#) for option descriptions.

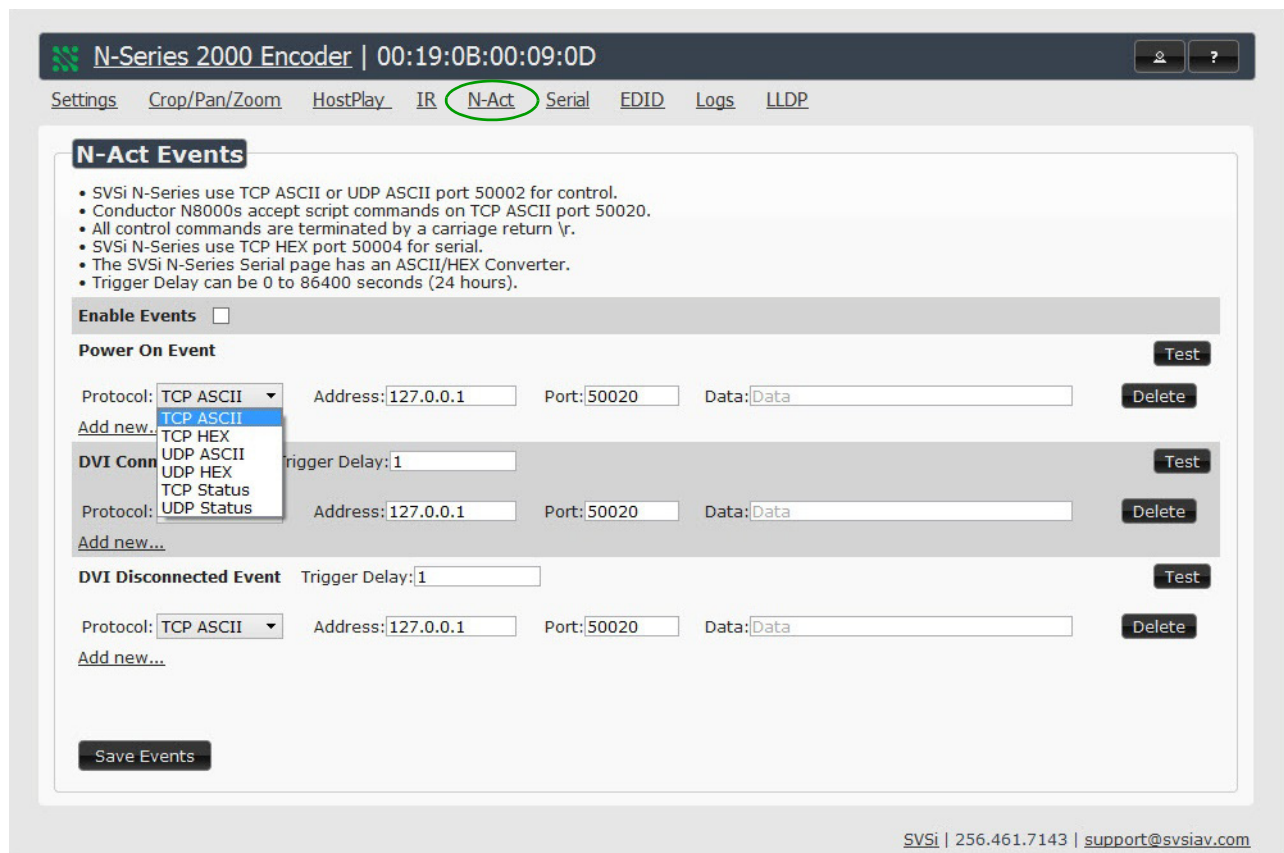

Figure 3-15. N-Act Page

Table 3-12. N-Act Page Options

Option	Description
Enable Events	Enable to activate the configured events.
Power on Event	Create/delete/test events to be performed when the Encoder powers on. Visit our website for more details on Application Programming Interface (API) commands.
DVI Connected Event	Create/delete/test events to be performed when the Encoder is connected to a video source. The Trigger Delay field specifies how long the device has to be connected for the command to be executed.

Table 3-12. N-Act Page Options (Continued)

Option	Description
DVI Disconnected Event	Create/delete/test events to be performed when the Encoder is disconnected from a video source. The Trigger Delay field specifies how long the device has to be disconnected for the command to be executed. This keeps accidental (momentary) disconnects from triggering the command sequence.
Save Events	Click to save changes made to this page.

SERIAL PAGE

Click the **Serial** link at the top of any of the main web pages to access the page shown in [Figure 3-16](#). This page allows you to upload and execute commands used for direct control of serial devices. Commands may be saved for future use and executed later. The **Serial Code** menu lists all saved commands. See [Table 3-13](#) for option descriptions.



If the **Port 5004/Serial Port** is currently in use by another device, sending commands from the **Serial** page will always return a **No Data** message and fail to send the commands.

N-Series 2000 Encoder | 00:19:0B:00:09:0D

Settings Crop/Pan/Zoom HostPlay IR N-Act **Serial** EDID Logs LLDP

N-Series Serial Database

Serial Code: [New] Save Delete Execute

ASCII:

HEX:

Response:

SVSi | 256.461.7143 | support@svsiav.com

Figure 3-16. Serial Page

Table 3-13. Serial Page Options

Option	Description
Serial Code	Create/select serial commands. Different vendors have different codes that can usually be found through a web search. Copy/paste new commands (in either ASCII or HEX) directly into the appropriate input space.
Save	Save the current code.
Delete	Delete the current code.
Execute	Apply the selected code to the Encoder's serial connection.
ASCII and HEX	Paste serial commands directly into either the ASCII or HEX field.
Response	View responses provided by the device receiving the serial command(s).

EDID PAGE

Click the **EDID** link at the top of any of the main web pages to access the page shown in [Figure 3-17](#). Every display has stored information that it communicates to the output device. This page allows you to view that information. See [Table 3-14](#) for option descriptions.

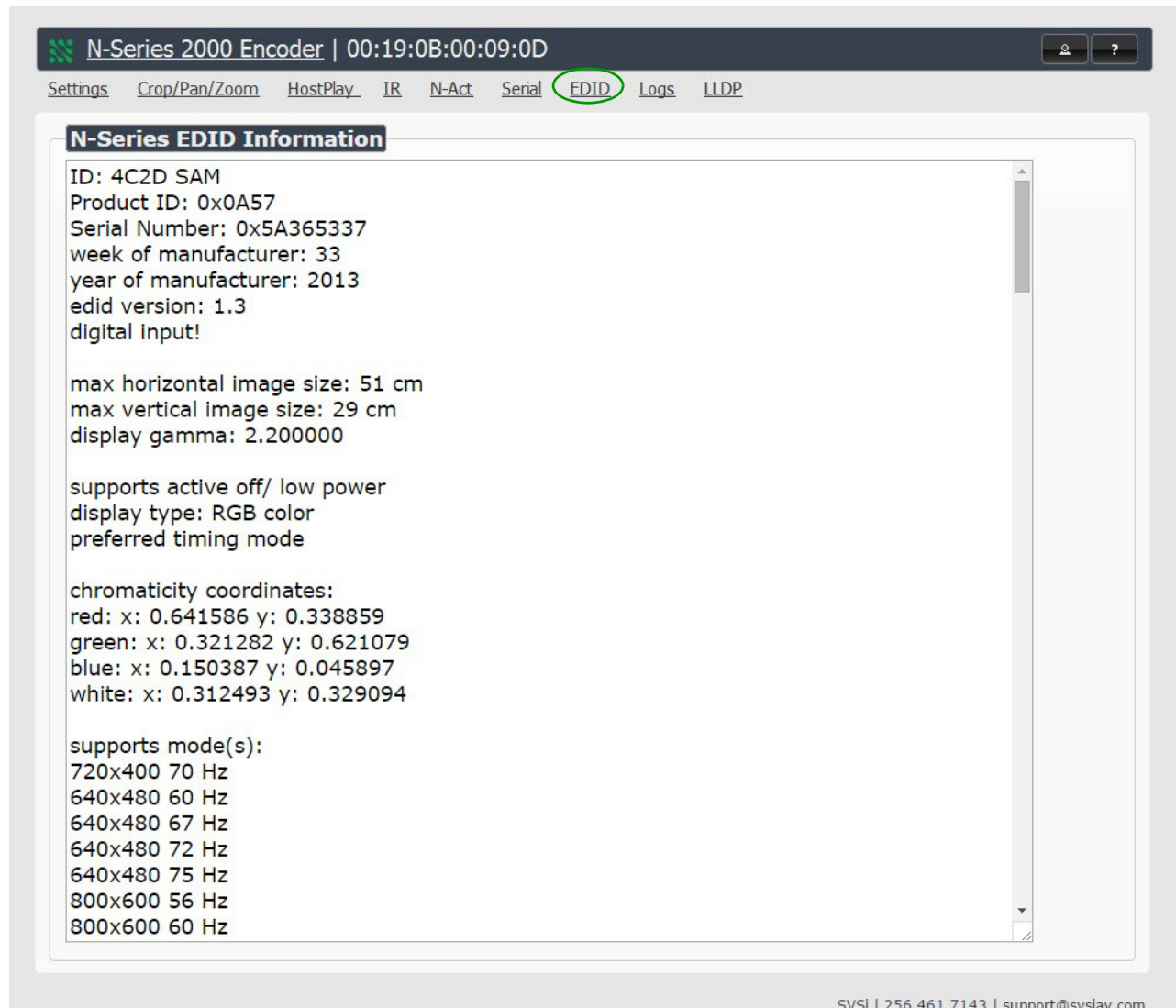

Figure 3-17. EDID Page

Table 3-14. EDID Page Options

Option	Description
Pass-thru	Displays EDID information for the display connected to the Encoder's pass thru port.
Local	Displays EDID information for the Encoder. This information is being provided to the source connected to the Encoder.

LOGS PAGE

Click the **Logs** link at the top of any of the main web pages to access the page shown in [Figure 3-18](#). The **Logs** page displays a command log that lists all TCP and UDP messages the unit receives. It also displays the web browser's IP address and gives you options to **Refresh** and **Reset Logs**.

N-Series 2000 Encoder | 00:19:0B:00:09:0D

Settings Crop/Pan/Zoom HostPlay IR N-Act Serial EDID **Logs** LLDP

Your IP address is 169.254.55.86 Refresh Logs Reset Logs

Command Log

Elapsed Time	IP	Port	Method	Command
14 min, 36 sec	Web page	50003	TCP	setSettings:name:00:19:0B:00:09:0D\r

SVSi | 256.461.7143 | support@svsiav.com

Figure 3-18. Logs Page

LLDP PAGE

Click the **LLDP** link at the top of any of the main web pages to access the page shown in [Figure 3-19](#). The **LLDP** page displays information from the Link Layer Discover Protocol (LLDP) packet which identifies the port number and switch the device is connected to.

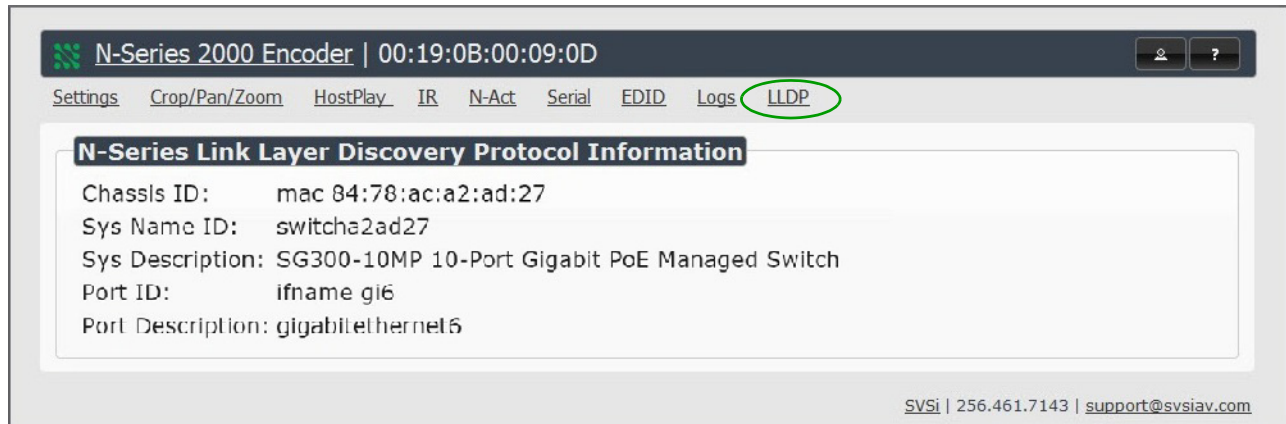

Figure 3-19. LLDP Page

Chapter 4

DECODER OPTIONS

DECODER INTRODUCTION

This chapter defines all of the configuration options available on your N2000 Series Decoders and is organized to reflect the graphical user interface (GUI) for ease of navigation.

DECODER CONFIGURATION OPTIONS

As explained in the previous chapter, you can access the GUI main pages by clicking the links in the top navigation bar. [Figure 4-1](#) shows the main navigation bar for the Decoder and provides hot links to the sections of this chapter which describe them.

[Settings Page](#) on page 69.

[Crop/Pan/Zoom Page](#) on page 86.

[LocalPlay Page](#) on page 88.

[IR Page](#) on page 90.



[N-Act Page](#) on page 91.

[Serial Page](#) on page 93.

[EDID Page](#) on page 95.

[Logs Page](#) on page 96.

[LLDP Page](#) on page 97.

Figure 4-1. Section Links

SETTINGS PAGE

Click the **Settings** link at the top of any of the main web pages to access the page shown in [Figure 4-2](#). This page is divided into several sections and also has links to other dialog boxes for additional configuration options. Refer to the following sections for detailed descriptions:

- [Decoder Setup Section](#) on page 70
- [Advanced Settings](#) on page 73
- [RS232 Settings](#) on page 77
- [Network Setup Section](#) on page 78
- [Status Section](#) on page 80
- [Change Password](#) on page 82
- [Software Section](#) on page 83
- [EDID Section](#) on page 84
- [Audio Downmixer Settings](#) on page 85

N-Series 2000 Decoder | S1 - Desktop

Settings Crop/Pan/Zoom LocalPlay IR N-Act Serial EDID Logs LLDP

Decoder Setup

Device Name: S1 - Desktop

Stream: 434

Audio Stream: 73

Audio Follows Video: Follows

Scaler: Enable

Output Mode: 1080p60

Live/Local: Live

Mute: Mute

Lineout Volume: Set Left/Right

Enable HDMI Audio: Auto (is off)

Cancel Save

Advanced Settings

RS232 Settings

Allow SVSi Multicast: P0 P1

Disable P1: Disable

Cancel Save

Network Setup

IP Mode: STATIC (STATIC)

IP address: 169.254.243.238 (169.254.243.238)

Netmask: 255.255.0.0 (255.255.0.0)

Gateway address: 169.254.1.1 (169.254.1.1)

Trial Save

Status

DVI Status: disconnected

Input Resolution: No Source

Port 50001 Source IP: Disconnected (Flush)

Port 50002 Source IP: Disconnected (Flush)

Serial Source IP: Disconnected (Flush)

Change Password

Change Password

Software

Serial: N222A040001664

MAC address: 00:19:0B:00:1E:5B

Web Version: 1/7/2015

Firmware Version: 1/7/2015

Factory Restore Reboot

EDID

Show EDID

Audio Downmixer

Audio Downmixer Settings

SVSi | 256.461.7143 | support@svsiav.com

Figure 4-2. Settings Page

Decoder Setup Section

The **Decoder Setup** section of the **Settings** page is shown in [Figure 4-3](#). Options are described in [Table 4-1](#).

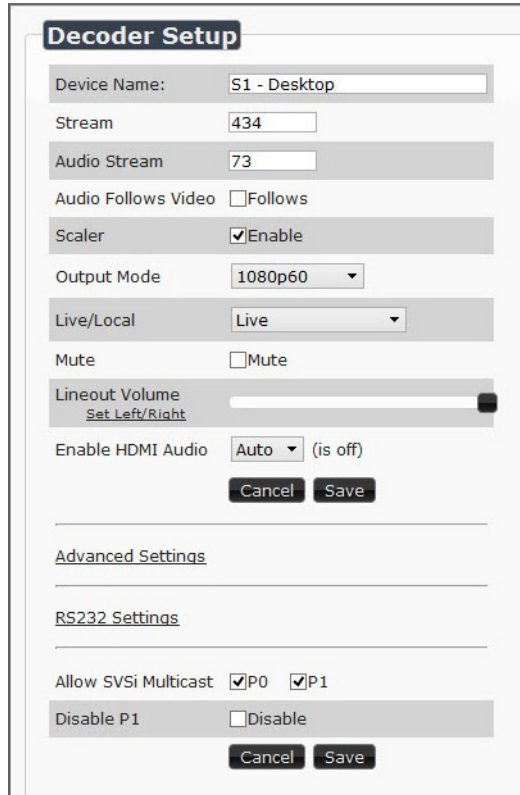

Figure 4-3. Decoder Setup Section

Table 4-1. Settings Page: Decoder Setup Section

Option	Description	Notes
Device Name	Enter a user-friendly name for the unit.	More descriptive names in this field help you organize and manage the SVSi system efficiently. Names based on the unit's location and function are very useful. Some good examples are Lobby-Left-VGA (for left side of lobby, VGA input) or CR201-HDMI (for Conference Room 201, HDMI input). Keep in mind the matrices are organized alphanumerically.

Table 4-1. Settings Page: Decoder Setup Section (Continued)

Option	Description	Notes
Stream	View/edit the current transmit stream number.	To better understand this setting, think of Decoders more like a channel on a cable box, rather than a traditional AV Matrix. Each Decoder must have a unique stream number, just like every channel must have a unique channel number (e.g., Food Network and HGTV cannot both be on channel 201).
Audio Stream	View/edit the current audio receive stream number.	
Audio Follows Video	Enable to force the Audio Stream to the same as the video stream.	
Scaler	Enable to scale outgoing content to a fixed resolution or to use the Crop/Pan/Zoom functions.	
Output Mode	Select the output resolution of the video to be transmitted to the video output device (e.g., LCD) (the Scaler check box must be enabled for this to be applicable).	
Live/Local	Select live video or locally stored images for transmission to the video output device (e.g., LCD). When video is not available, it automatically goes into local mode.	When video is not available, the most recently played local playlist is displayed.
Mute	Enable to mute output audio.	
Lineout Volume	This slider controls the output gain on the analog audio output. By default, it controls both the left and right lineout channels. Click the Set Left/Right link to control channels individually.	
Enable HDMI Audio		ON forces audio on at all times. AUTO reads the EDID of the connected device to determine whether or not to send audio.
Advanced Settings	Refer to Advanced Settings on page 73 for details on the options available from this link.	
RS232 Settings	Refer to RS232 Settings on page 77 for details on the options available from this link.	

Table 4-1. Settings Page: Decoder Setup Section (Continued)

Option	Description	Notes
Allow SVSi Multicast	Disable this option to prevent the port from outputting multicast video traffic.	Particularly useful if you are connecting a non-SVSi device to a port for network-based control.
Disable P1	Completely disables the P1 port for all traffic.	Once disabled, anything connected to the P1 port will no longer be available on the network.
Cancel	Click to return all controls to the last saved configuration.	
Save	Click to accept changes made to these controls.	

Advanced Settings

The section of the **Settings** page shown in [Figure 4-4](#) is displayed when you click the **Advanced Settings** link. Options are described in [Table 4-2](#).

Advanced Settings	
Settings Lock	<input type="checkbox"/> Enable
Input audio for LocalPlay	<input type="checkbox"/> Enable
YCbCr 4:2:2 Output	Off (is off)
Simplified DVI Detect	<input type="checkbox"/> Enable
Last Frame Hold	<input type="checkbox"/> Enable
Gen1 Compatibility	Auto (is off)
DVI off on stream loss	<input type="checkbox"/> Enable
DVI Enable	<input checked="" type="checkbox"/> Enable
Invert DVI Horizontal Sync	<input type="checkbox"/> Enable
Invert DVI Vertical Sync	<input type="checkbox"/> Enable
Gratuitous ARP	<input type="checkbox"/> Enable
ARP Interval(secs)	50
Unsolicited Status	<input checked="" type="checkbox"/> Enable
Send Status Address	0.0.0.0
Status Interval(secs)	10
Discovery Packet Transmit	<input checked="" type="checkbox"/> Enable
Discovery Interval(secs)	10
Serial Master Enable	<input type="checkbox"/> Enable
Serial Slave Address	0.0.0.0
IR Command Holdoff	25 ms
IR Repeat Holdoff	90 ms
IGMP Joins on Stream Loss	<input checked="" type="checkbox"/> Enable
IGMP Join Interval	3 secs
Auto Sync Control	<input checked="" type="checkbox"/> Enable
Auto Sync Rate	8000000
Maintain Aspect Ratio	<input checked="" type="checkbox"/> Enable
Enable SNMP	<input type="checkbox"/> Enable

Figure 4-4. Advanced Settings

Table 4-2. Settings Page: Advanced Settings

Option	Description	Notes
Settings Lock	Enable to lock the Decoder IP settings and stream number, preventing automated processes (from N-Able or N-Command) from occurring.	This does <i>not</i> prevent a control system from making changes or a user from manually making changes.
Input audio for LocalPlay	Select to enable the input audio when the Live/Local menu is set to one of the local images.	
YCbCr 4:2:2 Output	Set YCbCr output to be disabled, enabled, or selected automatically based on the connected display.	
Simplified DVI Detect	Select to enable the detection of a display device using a simple line level check.	
Last Frame Hold	Select to cause the Encoder to continue playing the last valid video frame if the network connection is lost.	When enabled, Local Play will not appear.
Gen 1 Compatibility	Set compatibility with the color space of legacy equipment to be disabled, enabled, or selected automatically based on the identifying information in the video stream.	
DVI off on stream loss	Select to disable the video output drive when the video stream is not available.	
DVI Enable	Select to enable output video.	
Invert DVI Horizontal Sync	Select to invert the polarity of the horizontal sync signal driven to the display device.	
Invert DVI Vertical Sync	Select to invert the polarity of the vertical sync signal driven to the display device.	
Gratuitous ARP	Enable the Decoder to send a periodic Address Resolution Protocol (ARP) packet to the network.	
ARP Interval (secs)	Determine how often (in seconds) the unit transmits gratuitous ARP packets.	
Unsolicited Status	Enable the Decoder to send a periodic status packet to the Send Status Address described below.	

Table 4-2. Settings Page: Advanced Settings (Continued)

Option	Description	Notes
Send Status Address	When Unsolicited Status is enabled, the Decoder sends a periodic status packet to the IP address specified here.	
Status Interval (secs)	Determine how often (in seconds) the unit transmits status packets.	
Discovery Packet Transmit	Enable the SVSi multicast discovery service (which is used to identify units).	This is useful for larger network integrations when broadcast packets will not cover the entire network. Enabled by default.
Discovery Interval (secs)	Determine how often (in seconds) the unit transmits discovery packets.	
Serial Master Enable	Enable this device to be the master to the designated client.	
Serial Client Address	Enter the IP address of the serial client device.	
IR Command Holdoff	Set the delay between IR command portions. The default setting is 25 ms.	IR commands are sent in two parts. This setting is the time (in milliseconds) between transmission of part one and part two. The second part of the command is inverted for confirmation purposes.
IR Repeat Holdoff	Set the repeat delay between IR commands. The default setting is 90 ms.	This is the amount of time before a new command is sent. For example, when pressing and holding the volume button on a remote control, this is how long until the command is repeated.
IGMP Joins on Stream Loss	Enable to send Internet Group Management Protocol (IGMP) join messages when no incoming stream is detected.	
IGMP Join Interval	Delay in seconds between sending IGMP join messages (if IGMP Joins on Stream Loss is enabled).	
Auto Sync Control	Enable synchronization of vertical sync with the network.	Enable this option when using multiple Decoders (e.g, when building a video wall) that must be synchronized together.
Auto Sync Rate	Set the rate at which the vertical sync adjusts.	

Table 4-2. Settings Page: Advanced Settings (Continued)

Option	Description	Notes
Maintain Aspect Ratio	When scalers are enabled, enabling this check box maintains the source's aspect ratio.	
Enable SNMP	Enable to allow the device to send Simple Network Management Protocol (SNMP) packets.	

RS232 Settings

The section of the **Settings** page shown in [Figure 4-5](#) is displayed when you click the **RS232 Settings** link. Options are described in [Table 4-3](#).

The screenshot shows a form titled "RS232 Settings" with four rows of settings, each with a label and a dropdown menu:

- RS232 Baud Rate: 9600
- RS232 Data Bits: 8
- RS232 Parity: none
- RS232 Stop Bits: 1

Figure 4-5. RS232 Settings

Table 4-3. Settings Page: RS232 Settings

Option	Description
RS232 Baud Rate	Select the appropriate baud rate for the RS232 serial interface. Default is 9600.
RS232 Data Bits	Select the appropriate data bit count for the RS232 serial interface. Default is 8.
RS232 Parity	Select the appropriate parity for the RS232 serial interface. Default is no parity (none).
RS232 Stop Bits	Select the appropriate number of stop bits for the RS232 serial interface. Default is 1.

Network Setup Section

The **Network Setup** section of the **Settings** page is shown in [Figure 4-6](#). Options are described in [Table 4-4](#).

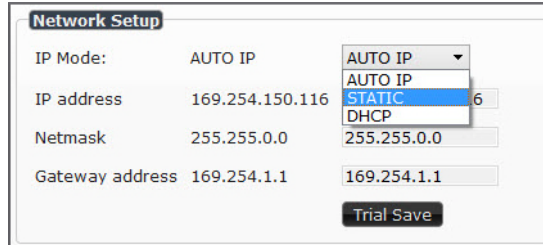

Figure 4-6. Network Setup Section

Table 4-4. Settings Page: Network Setup Section

Option	Description	Notes
IP Mode	Configure the IP address mode. When set to AUTO IP , an IP Address in the range of 169.254.xxx.xxx with Netmask of 255.255.0.0 and Gateway address of 169.254.1.1 will be automatically assigned to the N2000 Decoder by the control software. When set to DHCP , an IP Address in the range of the DHCP server on the network will be automatically assigned to the N2000 Decoder. When set to STATIC , an IP address , Netmask , and Gateway address must be manually entered.	Using DHCP is generally not recommended. If the device is set to DHCP and fails to receive an address from the DHCP server in time, it will revert back to the AUTO IP Address (169.254.xxx.xxx) until the unit is rebooted.
IP address	View the current IP address of the N2000 Decoder. When in STATIC mode, enter a new IP address into this field.	
Netmask	View the current Netmask of the N2000 Decoder. When in STATIC mode, enter a new Netmask into this field.	

Table 4-4. Settings Page: Network Setup Section (Continued)

Option	Description	Notes
Gateway address	View the current Gateway address of the N2000 Decoder. When in STATIC mode, enter a new Gateway address into this field.	
Trial Save	Click to initially save IP address changes. Once you log in to the unit using the new address, you will be able to confirm and accept the changes permanently.	

Status Section

The **Status** section of the **Settings** page is shown in [Figure 4-7](#). Options are described in [Table 4-5](#).

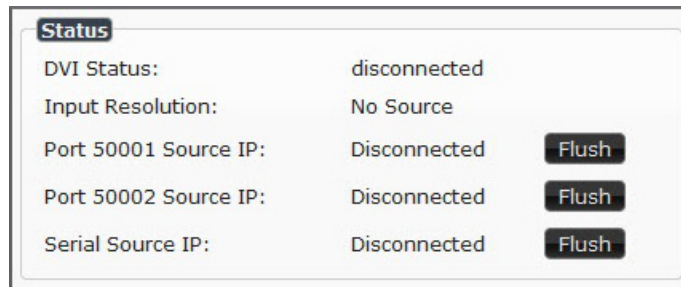

Figure 4-7. Status Section

Table 4-5. Settings Page: Status Section

Option	Description	Notes
DVI Status	Indicates if video is connected to the Decoder.	
Input Resolution	Indicates the video resolution of the incoming video source.	
Port 50001 Source IP	Shows the IP address of the currently connected device or displays Disconnected if no connection exists.	Port 50001 can only accept a single external connection at a time. If a device is currently showing the port occupied (by a control system or other device), then other connections will be rejected. However, connection attempts from the same IP will override the current connection.
Port 50002 Source IP	Shows the IP address of the currently connected device or displays Disconnected if no connection exists.	Port 50002 can only accept a single external connection at a time. If a device is currently showing the port occupied (by a control system or other device), then other connections will be rejected. However, connection attempts from the same IP will override the current connection.

Table 4-5. Settings Page: Status Section (Continued)

Option	Description	Notes
Serial Source IP	Shows the IP address of the currently connected device or displays Disconnected if no connection exists.	Only a single external connection can be accepted on the port. If a device is currently showing the port occupied (by a control system or other device), then other connections will be rejected. However, connection attempts from the same IP will override the current connection.
Flush buttons	These buttons reset the port.	

Change Password

To change the N2000 Decoder interface password, enter the current password in the field labeled **Old Password**, and enter a new password in the **New Password** and **Confirm Password** fields. Click **Change PW** to accept the new password.

A screenshot of a web form titled "Change Password". At the top left of the form is a tab labeled "Change Password". Below the tab is a link that also says "Change Password". The form contains three input fields: "Old Password:", "New Password:", and "Confirm Password:". To the right of the "Confirm Password:" field is a button labeled "Change PW".

Figure 4-8. Change Password



This password needs to match N-Able's stored password to allow auto-login using N-Able.

Software Section

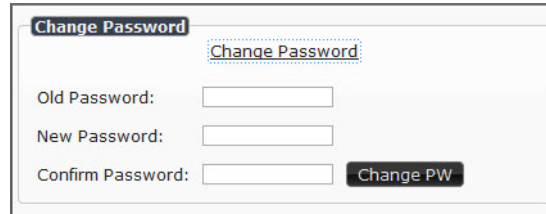
The **Software** section of the **Settings** page is shown in [Figure 4-9](#). Options are described in [Table 4-6](#).

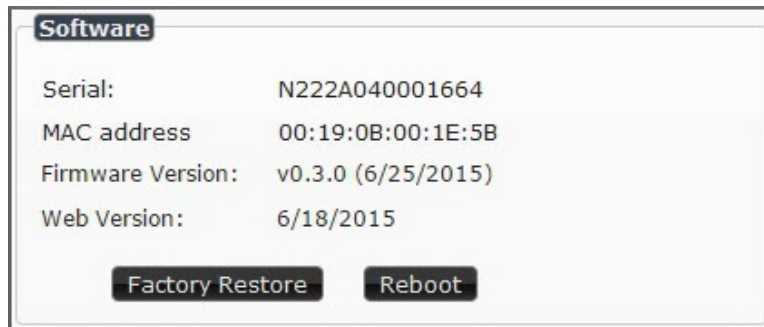

Figure 4-9. Software Section

Table 4-6. Settings Page: Software Section

Option	Description
Serial	Displays the serial number of the N2000 Decoder.
MAC Address	Displays the MAC address of the network interface of the N2000 Decoder.
Web Version	Displays the date code for the currently running version of the web interface.
Firmware Version	Displays the date code for the currently running version of the N2000 Decoder internal firmware.
Factory Restore	Click to restore the device to the original factory settings. This resets everything except the IP address (including name, stream number, serial settings, etc.).
Reboot	Click to reboot the device (does not affect current configuration).

Audio Downmixer Settings

The section of the **Settings** page shown in [Figure 4-11](#), is displayed when you click the **Audio Downmixer Settings** link. Options are described in [Table 4-7](#).

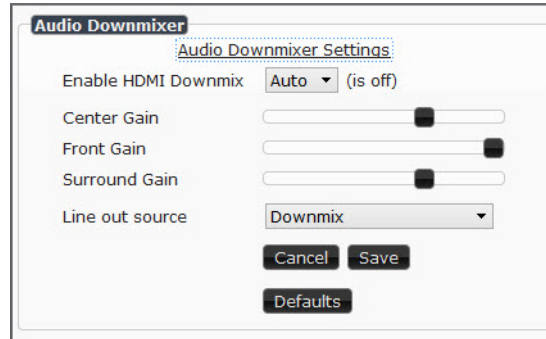

Figure 4-11. Audio Downmixer Settings

Table 4-8. Settings Page: Audio Downmixer Settings

Option	Description
Enable HDMI Downmix	Set HDMI audio downmixing to be disabled, enabled, or selected automatically when receiving a 7.1 audio source.
Center Gain slider	Set percentage of audio on center channel mixed into left and right output when downmixing.
Front Gain slider	Set percentage of audio on front left and right channels mixed into left and right output (respectively).
Surround Gain slider	Set percentage of audio on surround when downmixing left and right channels mixed into left and right output (respectively).
Line out source	Select a line out source or select Downmix when using the downmixer.
Cancel	Click to return all controls to the last saved configuration.
Save	Click to accept changes made to these controls.
Defaults	Click to return all controls to their default settings.

CROP/PAN/ZOOM PAGE

Click the **Crop/Pan/Zoom** link at the top of any of the main web pages to access the page shown in [Figure 4-12](#). This page allows you to customize the viewable portion of the input. See [Table 4-9](#) for option descriptions.

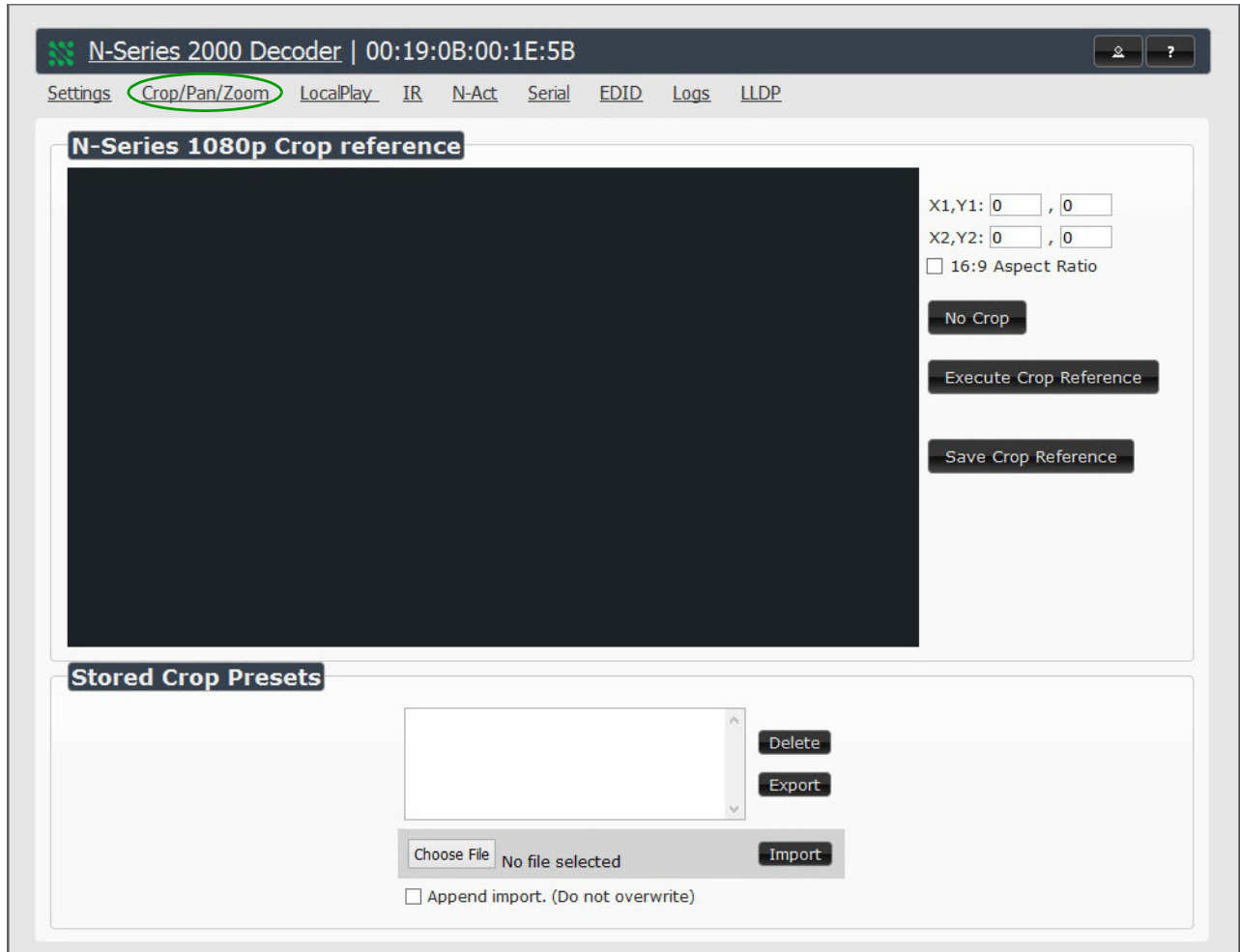

Figure 4-12. Crop/Pan/Zoom Page

Table 4-9. Crop/Pan/Zoom Page Options

Option	Description
X1, Y1	Set pixel coordinates of viewing area (top left).
X2, Y2	Set pixel coordinates of viewing area (bottom right).
16:9 Aspect Ratio	Enable to force to a 16:9 ratio.
No Crop	Click to disable existing crop settings and return unit to default output settings.
Execute Crop Reference	Click to execute changes.

Table 4-9. Crop/Pan/Zoom Page Options (Continued)

Option	Description
Save Crop Reference	Click to save the current settings and store them as a preset for later use. Presets can be used by third-party controllers.
Stored Crop Presets	Use this section of the page to select/delete/export/import cropping presets.

LOCALPLAY PAGE

Click the **LocalPlay** link at the top of any of the main web pages to access the screen shown in [Figure 4-13](#). This page allows you to upload new images to the Decoders and configure the image playlists. The playlist will be shown on the display when no video is being transmitted or received. You can show a single image or set up multiple images to be displayed at a customized animation rate. See [Table 4-11](#) for option descriptions.

N-Series LocalPlay

Edit Playlist : Remington Save

Playlist 1

Name: Remington

Output Mode: Currently 1280x720

Audio: No Audio

Slide1.BMP.jpg	1 sec
Slide2.BMP.jpg	1 sec
Slide3.BMP.jpg	1 sec
Slide4.BMP.jpg	1 sec
Slide5.BMP.jpg	1 sec
<no image>	1 sec
<no image>	1 sec
<no image>	1 sec
<no image>	1 sec
<no image>	1 sec

[Show More \(10 / 64\)](#)

Image/Audio DB

Choose File No file selected Upload 90.36 MiB free

Keep Aspect Fill: #000000 Scale: 1280x720

Slide1.BMP.jpg

Default_Lo..._N2000	1280x720
Slide1.BMP.jpg	1280x720
Slide2.BMP.jpg	1280x720
Slide3.BMP.jpg	1280x720
Slide4.BMP.jpg	1280x720
Slide5.BMP.jpg	1280x720

Delete Image(s)

No Audio Selected

Delete Audio

SVSi | 256.461.7143 | support@svsiav.com

Figure 4-13. LocalPlay Page

Table 4-11. LocalPlay Page Options

Option	Description
Edit Playlist	Select a playlist from the drop-down menu to view/edit the images currently used in the chosen image playlists. If more than one image appears in the list, a transition time can be set for each image.
Save	Click to save the current configuration.
Name	View/edit playlist names.
Output Mode	Select the resolution you want the image(s) to play in.
Audio	Select an audio file to play while the LocalPlay image is on the screen.
Image List	Allows you to customize what images are displayed, the transition time for each image, etc.
Image/Audio DB	This section allows you to upload images to the N2000 Decoder image database. You can also use the Fill field to customize the background color (used behind LocalPlay images that do not take up the entire screen).
Delete Image(s)	Delete the selected image file from the playlist.
Delete Audio	Delete the selected audio file from the playlist.

N-ACT PAGE

Click the **N-Act** link at the top of any of the main web pages to access the page shown in [Figure 4-15](#). This page allows you to create command lists which are performed automatically by the unit based on power or video connection (without the use of an outside controller). For example, you can tell a projector and lights to come on when the Decoder powers up. You can add multiple commands for each event. See [Table 4-13](#) for option descriptions.

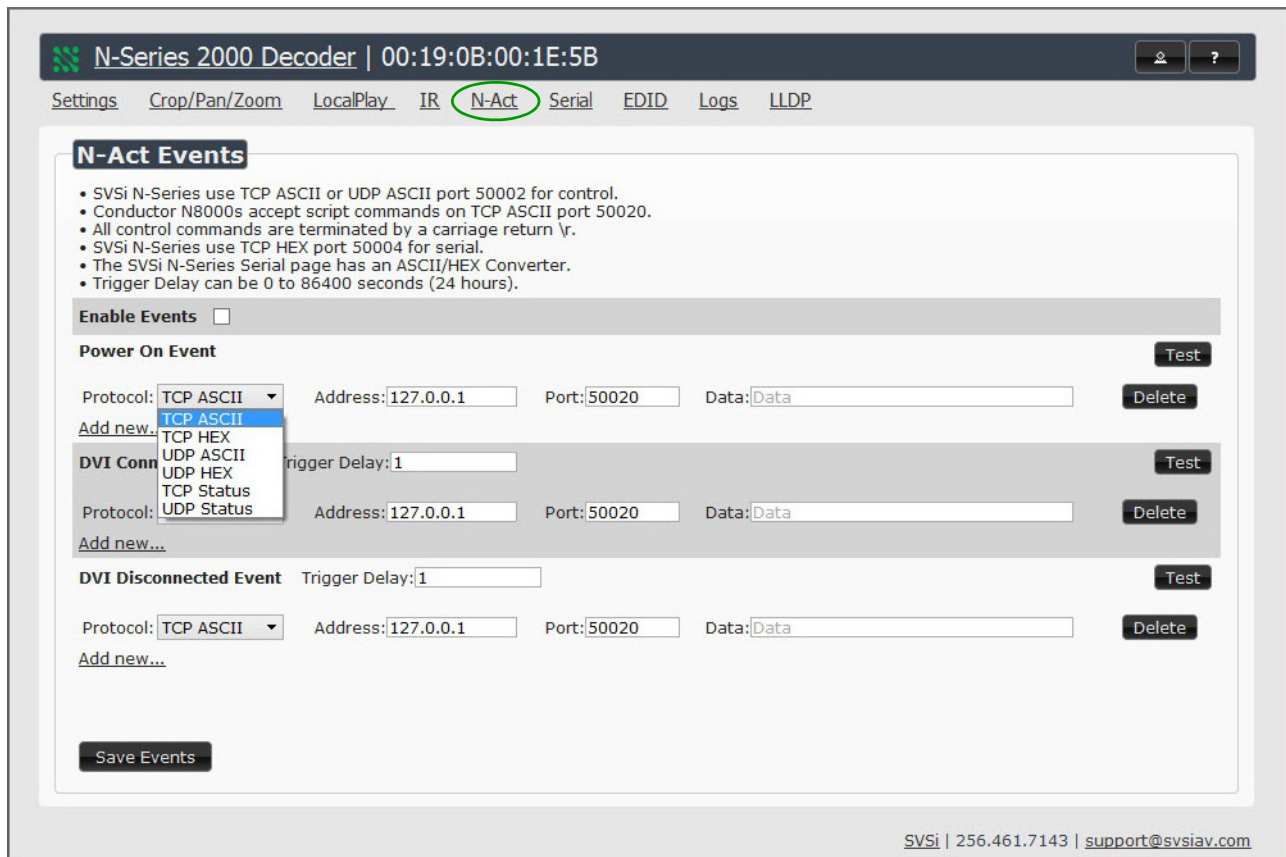

Figure 4-15. N-Act Page

Table 4-13. N-Act Page Options

Option	Description
Enable Events	Enable to activate the configured events.
Power on Event	Create/delete/test events to be performed when the Decoder powers on. Visit our website for more details on Application Programming Interface (API) commands.

Table 4-13. N-Act Page Options (Continued)

Option	Description
DVI Connected Event	Create/delete/test events to be performed when the Decoder is connected to an output display. The Trigger Delay field specifies how long the device has to be connected for the command to be executed.
DVI Disconnected Event	Create/delete/test events to be performed when the Decoder is disconnected from the output display. The Trigger Delay field specifies how long the device has to be disconnected for the command to be executed. This keeps accidental (momentary) disconnects from triggering the command sequence.
Save Events	Click to save changes made to this page.

SERIAL PAGE

Click the **Serial** link at the top of any of the main web pages to access the page shown in [Figure 4-16](#). This page allows you to upload and execute commands used for direct control of serial devices. Commands may be saved for future use and executed later. The **Serial Code** menu lists all saved commands. See [Table 4-14](#) for option descriptions.



*If the **Port 5004/Serial Port** is currently in use by another device, sending commands from the **Serial** page will always return a **No Data** message and fail to send the commands.*

N-Series 2000 Decoder | Lysle Dev

Settings Crop/Pan/Zoom LocalPlay IR N-Act **Serial** EDID Logs LLDP

N-Series Serial Database

Serial Code: serialcmd Save Delete Execute

ASCII:
\aa\12\00\01Pc

HEX:
aa 12 00 01 50 63

Response:

SVSi | 256.461.7143 | support@svsiav.com

Figure 4-16. Serial Page

Table 4-14. Serial Page Options

Option	Description
Serial Code	Create/select serial commands. Different vendors have different codes that can usually be found through a web search. Copy/paste new commands (in either ASCII or HEX) directly into the appropriate input space.
Save	Save the current code.
Delete	Delete the current code.
Execute	Send the selected code out the Decoder's serial connection.
ASCII and HEX	Paste serial commands directly into either the ASCII or HEX field.
Response	View responses provided by the device receiving the serial command(s).

EDID PAGE

Click the **EDID** link at the top of any of the main web pages to access the page shown in [Figure 4-17](#). Every display has stored information that it communicates to the output device. This page allows you to view the EDID information of the connected output display.

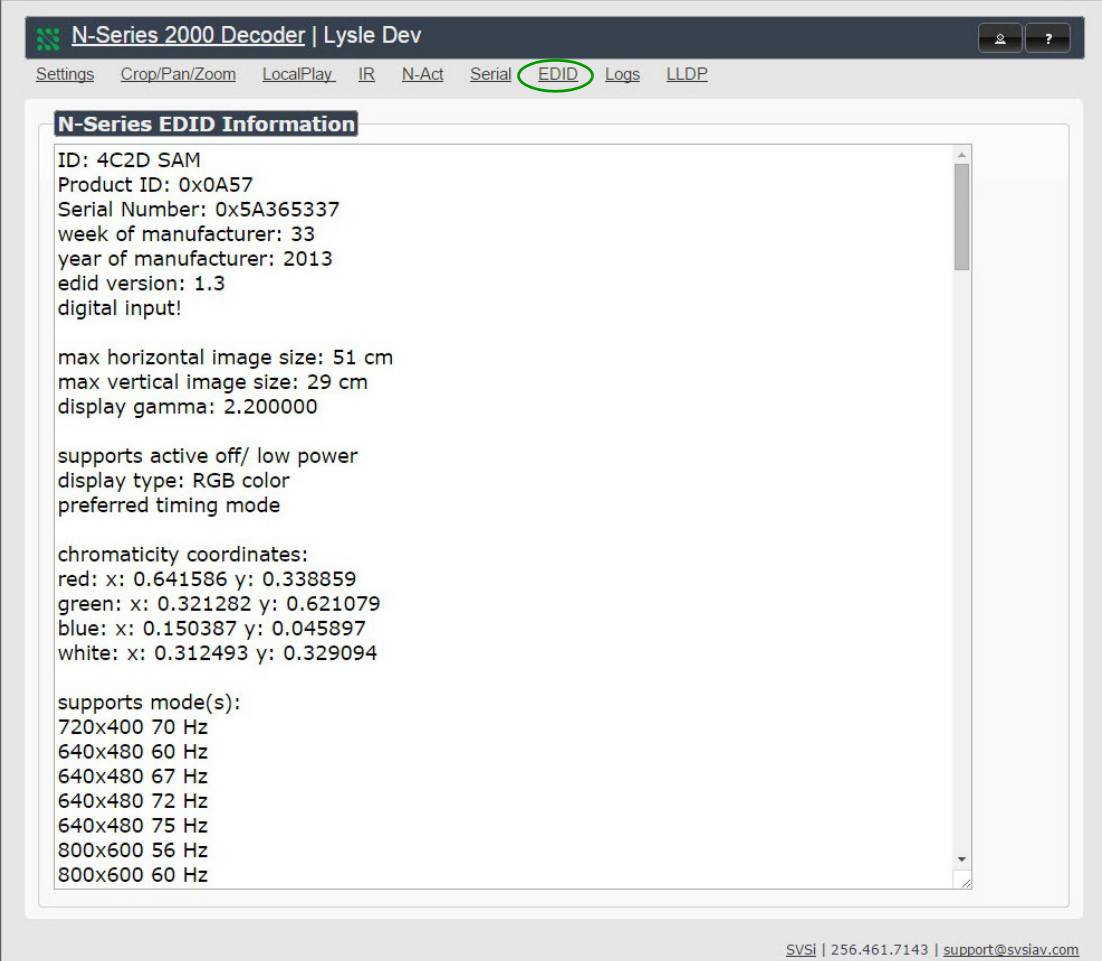

N-Series 2000 Decoder | Lysle Dev

Settings Crop/Pan/Zoom LocalPlay IR N-Act Serial **EDID** Logs LLDP

N-Series EDID Information

ID: 4C2D SAM
Product ID: 0x0A57
Serial Number: 0x5A365337
week of manufacturer: 33
year of manufacturer: 2013
edid version: 1.3
digital input!

max horizontal image size: 51 cm
max vertical image size: 29 cm
display gamma: 2.200000

supports active off/ low power
display type: RGB color
preferred timing mode

chromaticity coordinates:
red: x: 0.641586 y: 0.338859
green: x: 0.321282 y: 0.621079
blue: x: 0.150387 y: 0.045897
white: x: 0.312493 y: 0.329094

supports mode(s):
720x400 70 Hz
640x480 60 Hz
640x480 67 Hz
640x480 72 Hz
640x480 75 Hz
800x600 56 Hz
800x600 60 Hz

SVSi | 256.461.7143 | support@svsiav.com

Figure 4-17. EDID Page

LOGS PAGE

Click the **Logs** link at the top of any of the main web pages to access the page shown in [Figure 4-18](#). The **Logs** page displays a command log that lists all TCP and UDP messages the unit receives. It also displays the unit's IP address and gives you options to **Refresh** and **Reset Logs**.

N-Series 2000 Decoder | Jordan - N2221

Settings Crop/Pan/Zoom LocalPlay IR N-Act Serial EDID **Logs** LLDP

Your IP address is 169.254.55.86 Refresh Logs Reset Logs

Command Log

Elapsed Time	IP	Port	Method	Command
41 min, 57 sec	Web page	50003	TCP	set:1001\r
4 hrs, 14 min, 23 sec	Web page	50003	TCP	set:1004\r
4 hrs, 14 min, 29 sec	Web page	50003	TCP	set:1001\r
4 hrs, 15 min, 31 sec	Web page	50003	TCP	set:1004\r
6 days, 22 hrs, 58 min, 52 sec	Web page	50003	TCP	set:6995\r
6 days, 23 hrs, 50 min, 49 sec	Web page	50003	TCP	set:1003\r
7 days, 45 sec	Web page	50003	TCP	set:1001\r
7 days, 1 min, 1 sec	Web page	50003	TCP	set:1003\r
7 days, 10 min, 33 sec	Web page	50003	TCP	set:1002\r
7 days, 11 min, 51 sec	Web page	50003	TCP	set:1005\r
7 days, 18 min, 22 sec	Web page	50003	TCP	set:1004\r
7 days, 52 min	Web page	50003	TCP	scalerenable\r
7 days, 52 min, 17 sec	Web page	50003	TCP	scalerdisable\r
7 days, 2 hrs, 27 min, 17 sec	Web page	50003	TCP	setSettings:autoSyncControl:on\r
7 days, 2 hrs, 29 min, 4 sec	Web page	50003	TCP	set:6995\r

Figure 4-18. Logs Page

LLDP PAGE

Click the **LLDP** link at the top of any of the main web pages to access the page shown in [Figure 4-19](#). The **LLDP** page displays information from the Link Layer Discover Protocol (LLDP) packet which identifies the port number and switch the device is connected to.

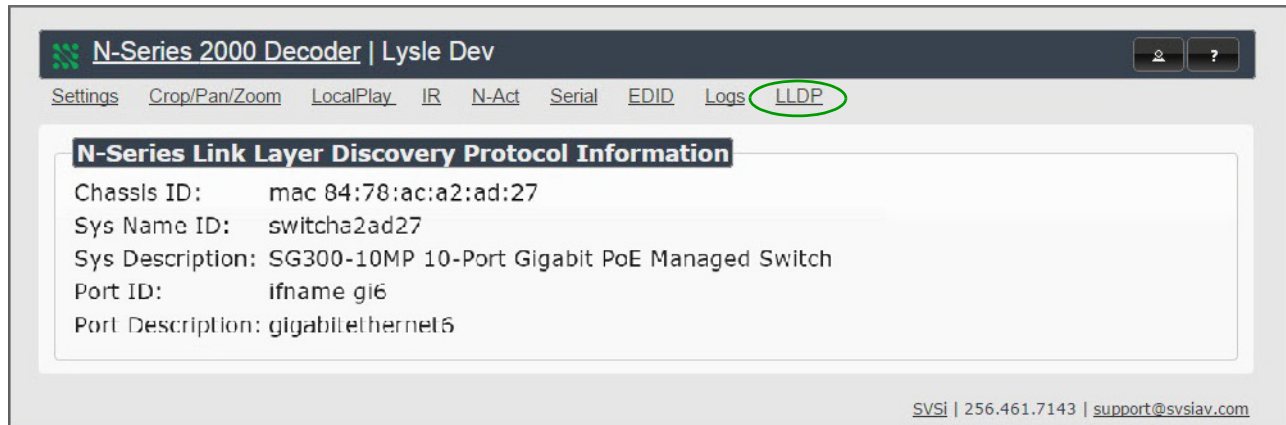

Figure 4-19. LLDP Page

Chapter 5

TROUBLESHOOTING

INTRODUCTION

This chapter contains possible solutions to some common issues. Should you encounter any problems not covered by these guidelines, please contact SVSi technical support via email (support@svsiav.com) or call 256.461.7143 x9900. You can also visit our support webpage at support.svsiav.com.

Table 5-1. Troubleshooting Suggestions

Issues	Suggestions
LocalPlay graphic displays instead of the stream from the Encoder.	<ul style="list-style-type: none"> • Verify Decoder is assigned to view a valid stream (of an active Encoder). • Verify Decoder is currently in LivePlay mode (its name will display in black text on the Video Matrix page). You can change to Live mode on the Settings page (see Table 4-1 on page 70 for more details). • Verify network is properly configured and set up. If needed, connect Encoder's network port to Decoder to bypass the network.
HostPlay graphic displays instead of the video from the source.	<ul style="list-style-type: none"> • Verify Encoder is in LivePlay mode (its name will display in black text on the Video Matrix page). You can change to Live mode on the Settings page (see Table 3-1 on page 39 for more details). • Verify source is attached and is outputting a valid signal (DVI LED on Encoder is on).
Unsupported Resolution graphic displays.	<ul style="list-style-type: none"> • Change source resolution to a valid resolution (try 720p60). • Verify cabling is correct.
Copy Protected Content screen displays.	<ul style="list-style-type: none"> • Contact SVSi technical support.
Black screen/no graphic displays.	<ul style="list-style-type: none"> • Set Decoder to LocalPlay. If the LocalPlay graphic does not appear, check the display input settings and cabling. As mentioned previously in this table, you can change to the Local mode on the Decoder's Settings page. • If LocalPlay appears, set Decoder to live play and verify network is configured properly.
No audio is detected.	<ul style="list-style-type: none"> • If there is no audio on <u>all</u> Decoders, verify audio settings are correct on Encoder. • If there is no audio on a single Decoder, verify audio settings are correct on Decoder.

Table 5-1. Troubleshooting Suggestions (Continued)

Issues	Suggestions
Device has been discovered in N-Able, but the configuration pages do not open when double-clicking device name on the Video Matrix page.	<ul style="list-style-type: none"> Make sure your computer is in the same IP address range as the unit. See Setting Up Your Host Computer on page 21 for more information.
When changing the audio type, there are problems with audio in/out.	<ul style="list-style-type: none"> Check the Audio Source and HDMI Audio settings on the Settings page. For example, if you are trying to change the audio type to make the input of the Encoder HDMI embedded audio in/analog audio out from the Decoder, these settings cannot be set to Auto. Set the Encoder to Audio Source > ON (embedded digital audio on DVI connection) and the Decoder to HDMI Audio > OFF (analog output on the Phoenix connection).
Not receiving audio.	<ul style="list-style-type: none"> Check that the Decoder has proper audio stream setting (typically Audio follows Video).
Not receiving analog video through the Encoder.	<ul style="list-style-type: none"> Make sure that analog converter is in a DVI-I pin-out. <i>Note: All SVSi outputs are digital-only (DVI pass-thru on Encoder and DVI output on Decoder).</i> OR If using a Y cable (N9420) and an HDMI source is already connected to the Encoder, disconnect the HDMI source. Encoders give preference to HDMI and will not allow analog signal to pass while it is connected.
Video output is stuttering.	<ul style="list-style-type: none"> This could be a network bandwidth issue where the full video stream is not reliably getting from Encoder to Decoder. Contact your network administrator for assistance.
Experiencing a red/blue color swap.	<ul style="list-style-type: none"> Check Gen1 Compatibility Mode. If the entire system is N-Series, set to Off. If the system is mixed (V-Series and N-Series), set to On for the N-Series Decoder. See Advanced Settings on page 73 for more information on this mode.
Serial port is not working as expected.	<ul style="list-style-type: none"> Verify the RS232 Settings on the Settings page. Flush the serial port on the Settings page if another device is connected. Connecting the Tx and Rx pins on the RS232 connector creates a loopback that could also help when troubleshooting.