

Overview

The Alero ALR-AMP-8 8-Zone Power Amplifier (FG1104-01) features 16 audio distribution channels and Class D power amplification in a compact 1RU chassis.

Important Safety Instructions

Note: Please adhere to all of the following safety instructions:

1. Read the instructions.
2. Keep the instructions.
3. Heed all warnings.
4. Follow the instructions.
5. Do not use this apparatus near water.
6. Clean this apparatus only with a dry cloth.
7. Do not block any ventilation openings. Install in accordance with the manufacturer's instructions.
8. Do not install near any heat sources such as radiators, heat registers, stoves, or other apparatus (including amplifiers) that produce heat.
9. Do not defeat the safety purpose of the grounding type plug. The grounding plug has two blades and a third grounding prong. The third prong is provided for your safety. If the provided plug does not fit into your outlet, consult an electrician for replacement of the obsolete outlet.
10. Protect the power cord from being walked on or pinched particularly at plugs, convenience receptacles, and the point where they exit from the apparatus.
11. Only use attachments/accessories specified by the manufacturer.
12. Use only with cart, stand, tripod, bracket, or table specified by the manufacturer, or sold with the apparatus. When a cart is used, use caution when moving the cart/apparatus combination to avoid injury from tip-over.
13. Unplug this apparatus during lightning storms or when unused for long periods of time.
14. Refer all servicing to qualified personnel. Servicing is required when the apparatus has been damaged in any way, such as power supply cord or plug is damaged, liquid has been spilled or objects have fallen into the apparatus, the apparatus has been exposed to rain or moisture, does not operate normally, or has been dropped.
15. The appliance coupler is used as the disconnect device and shall remain readily operable.

WARNING! To reduce the risk of fire or electric shock, do not expose this apparatus to rain or moisture.

WARNING! This apparatus shall be connected to a MAINS socket outlet with a protective earthing connection.

WARNING! This apparatus shall not be exposed to dripping or splashing, and no objects filled with liquids, such as vases, shall be placed on the apparatus.

DANGER! No user serviceable parts inside. Service is to be performed only by AMX.

Safety Symbol Definitions

	The exclamation point within an equilateral triangle is intended to alert the user to the presence of important operating and maintenance (servicing) instructions in the literature accompanying the product.
	The lightning flash with arrowhead symbol within an equilateral triangle is intended to alert the user to the presence of non-insulating, dangerous voltage within the product's enclosure that may be of sufficient magnitude to constitute a risk of electric shock to persons.

Certifications

The ALR-AMP-8 has the following safety certifications:
FCC, CE, UL, IEC, PSE, C-TICK.

Controlling the Alero ALR-AMP-8

Volume control for the ALR-AMP-8 is managed by an external pre-amp / audio switcher, such as the AMX Precis DSP. The ALR-AMP-8 can be powered on and off externally by using the two signals 12V trigger and 3-5V trigger.

A Signal Sense function is also provided which automatically can switch on the ALR-AMP-8 in the event of an audio signal and switch off the ALR-AMP-8 to enter standby mode when no audio signal has been present on the signal terminals for approximately 13 minutes.

Refer to the *Alero ALR-AMP-8 Instruction Manual* for details on On/Off Control via the 12V Trigger, 3-5V Trigger and Signal Sense.

Note: The Alero ALR-AMP-8 requires an external preamp for volume control.

Front Panel Components (LEDs)

The front panel features three LEDs:

POWER LED (Green/Red)

Indicates the current power state of the amp (Green = On, Red = Standby mode)

OC/CLIP LED (Yellow/Red)

The OC/CLIP LED indicates that the current of one or more of the speaker outputs has exceeded its maximum output:

- **Yellow** indicates an OC (over-current) shutdown of the amplifier output.- In the case of an OC event, the amplifier will shut down to protect itself, and indicate an OC event on this LED (yellow) and the OC pin (pin 8 on the 10-pin I/O port). An OC event can indicate a cable fault, installation fault or defective speaker.
- **Red** indicates an over-current event with the Power Supply. The LED will light red if internal temperature sensors on the power supply sense an abnormally high temperature, or if power supply over-current/over-load/power-limit circuits are triggered. In either case, the power supply will limit the amplifier output to keep the power supply within safe limits, while keeping the music playing.

THERMAL LED (Red)

The *Thermal Protection* LED indicates if one or more of the speaker outputs are shut down due to thermal protection.

- The temperatures of all the output channels are individually monitored, and if one or more of them reaches the thermal limit (105°C) then the respective Zones will shut down and go into soft start mode (Channels 1/2 = Zone 1, Channels 3/4 = Zone 2, etc), and the Thermal Protection LED will be lit.
- The other Zones will continue to be active. When the temperature has dropped below the thermal threshold, the respective Zone(s) start up again automatically.

Mounting the ALR-AMP-8 into an Equipment Rack

The ALR-AMP-8 can be mounted in a 19" equipment rack or on a solid flat surface. Use the included removable rack ears and removable feet for mounting.

Ventilation

Note: The maximum operating ambient temperature is 45°C (113°F).

- To ensure that the rack enclosure is adequately ventilated, there must be a minimum of 3" all around the ALR-AMP-8
- Sufficient airflow must be achieved (by convection or forced-air cooling) to satisfy the ventilation requirements of all the items of equipment installed within the rack.

Rack Mount Safety Instructions

- Mounting of the equipment in the rack should be such that a hazardous condition is not achieved due to uneven mechanical loading.
- Consideration should be given to the connection of the equipment to the supply circuit and the effect that overloading of the circuits might have on over current protection and supply wiring. Appropriate consideration of equipment nameplate ratings should be used when addressing this concern.
- Reliable earthing of rack-mounted equipment should be maintained. Particular attention should be given to supply connections other than direct connections to the branch circuit (e.g. use of power strips).

Wiring and Connections

All speaker wire connections must be made with the amplifier off. The amplifier must be off whenever you make changes to the input connections.

Connecting Audio Source Devices

Source Devices connect to the Input connectors on the rear panel. (FIG. 1):

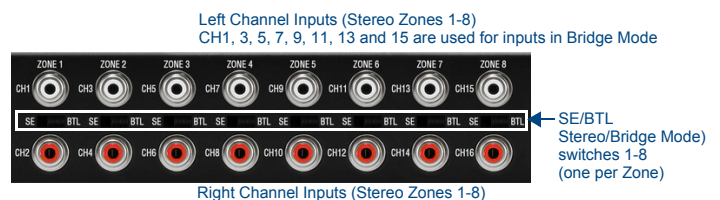

FIG. 1 Audio Input connectors (L/R pairs for 8 stereo inputs, 16 total)

- The Audio Inputs consist of 16 RCA/phono terminals; each of the single-ended input channels having a signal input and ground.
- Each Zone (1-8) consists of two channels (odd and even) that represent the left and right channels in a stereo pair. For example, CH1 and CH2 represent the left and right channels for Zone 1.

Audio (Signal) Inputs

The following table provides pinout information for the Audio Inputs:

Audio Input Connectors - Pinout Information			
PIN	Function	Description	Type
1	Signal Sense +	Single Ended Signal Positive	Input
2	Signal GND	Single Ended Signal GND	GND

SE/BTL (Stereo/Bridge Mode) Switches (1-8)

The ALR-AMP-8 features eight SE/BTL slide switches (located between the two RCA/phono input connectors for each Zone). These switches provide the ability to set each of the eight Zones to either Stereo Mode (SE) or Bridge Mode (BTL). Note that by default, all Audio Inputs are set to Stereo Mode.

- **Stereo Mode (SE):** In Stereo Mode, both channels are used for stereo audio input. Stereo mode provides true stereo separation between the left and right channels in each Zone.
- **Bridge Mode (BTL):** Bridge Mode uses one input channel of the amplifier to combine the power from both channels output into one single output. In Bridge Mode, the odd channels are used for audio input and the even channels are disconnected internally.

Connecting Input Devices in Stereo Mode

Stereo input devices use both input channels (left and right) for each Zone.

- **Odd-numbered channels** (with *white* connectors) should be used to connect to the **left** output on the source device.
- **Even-numbered channels** (with *red* connectors) should be used to connect to the **right** output on the source device.

The ALR-AMP-8 supports up to 8 stereo input devices, each one associated with an input Zone (1-8). Note that each Zone represents a stereo pair. For example, Zone 1 consists of CH1 (left channel) and CH2 (right channel). There is a direct correlation between the audio inputs and the speaker outputs. For example, a stereo device connected to the Zone 1 inputs (CH1 and CH2) will output on the CH1 (left) and CH2 (right) speaker outputs (FIG. 2):

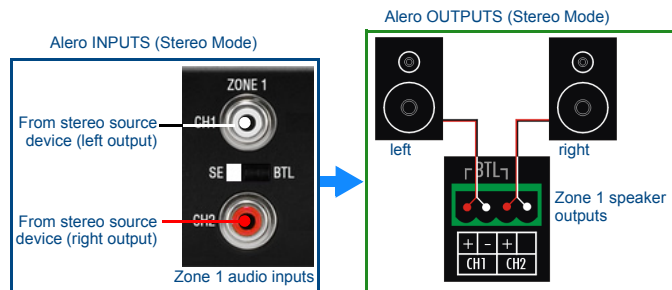

FIG. 2 Stereo Input - Zone 1 (CH1 and CH2) output on Speaker Outputs CH1 and CH2

Note: When connecting stereo input devices, verify that the Stereo/Bridge (SE/BTL) mode switch for the Zone is set to "SE". This is the default factory setting.

Connecting Input Devices in Bridge Mode

In Bridge Mode, input devices connect to the *left* input channels only. Note that left input connectors are white, and are the odd-numbered channels.

Note: When connecting bridged input devices, verify that the Stereo/Bridge (SE/BTL) mode switch for the Zone is set to "BTL". Refer to the Alero ALR-AMP-8 Instruction Manual for detailed instructions on connecting input devices in bridge mode.

Connecting Speakers

Note: All speaker connections must use **Class 2 Wiring**. Class 2 Wiring is required due to the fact that power is above 10W per channel under normal operating conditions.

! If speaker output is subject to incorrect loading there is the risk of overheating, overcurrent and premature shutdown of the affected zone.

Speakers connect to the captive-wire output terminals (CH1-CH16) on the rear panel (FIG. 3):

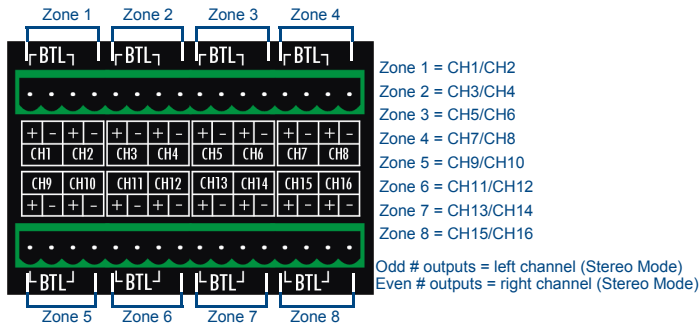
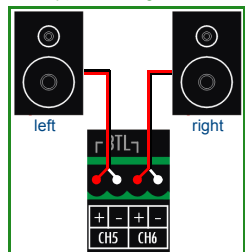

FIG. 3 Speaker (Output) Terminals (16 total, L/R pairs for 8 stereo outputs)

Each Zone (1-8) consists of two channels (an L/R pair in Stereo Mode), and each Channel (1-16) uses a 2-pin captive-wire connector to connect to speakers.

Stereo Speaker Wiring - CORRECT



Stereo Speaker Wiring - INCORRECT

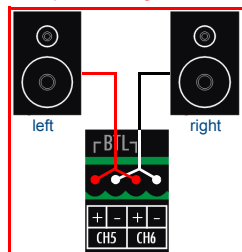

FIG. 4 Stereo Input - Zone 1 (CH1 and CH2) output on Speaker Outputs CH1 and CH2

! If incorrect wiring is used there is a risk of electrical shock and a fire hazard.

Note: For wiring runs longer than 80 feet, 14-gauge speaker wire is recommended.

Speaker Output Connectors

The speaker output connectors consist of two 16 pin captive-wire terminals; each of the output terminals having a "+" and "-" terminal. The label "BTL" on each speaker pair points to the pins that are used when connecting a single speaker to an input in Bridge Mode.

I/O (Control Input) Port

The 10-pin captive-wire I/O (Control Input) port is for external control and status indication:

10-Pin I/O Port - Pinout Information		
PIN	Function	Description
1	Signal Sense +	Single-ended Signal Sense input (+). This pin detects an input signal from a source device when the source device is active. Pin 1 (Signal Sense +) connects to one of the source device's input cables to provide a signal to the ALR-AMP-8 when the source device is active
2	Signal GND	Single Ended Signal GND
3	12V Trigger In	The ALR-AMP-8 can be turned On or placed in Standby mode externally via a 12V Trigger signal. A 12V trigger input is accessible via Pin 3. Typically, Pin 3 connects to a relay pin on a Controller's Relay port.
4	12V Trigger Out	The ALR-AMP-8 also provides a +12V Trigger output signal that can be used to turn on/off a downstream device where no trigger signal input is available. A +12V trigger output signal is provided on Pin 4. Pin 4 connects to a +12V Trigger (input) on a downstream amplifier. • When the ALR-AMP-8 is On, the output on Pin 4 will be +12V after 1 second • When the ALR-AMP-8 is in Standby mode the 12V will turn off.
5	GND	Logic / Trigger GND: Pin 5 provides a ground connection for the 3-5V Logic Level Trigger. Pin 5 connects to the GND pin of an I/O port on an external controller, such as a NetLinx Central Controller.
6	3-5V Trigger	Logic Level Trigger: The ALR-AMP-8 can be also turned On or placed in Standby mode externally via a 3-5V Logic Level trigger signal. A 3-5V trigger input is accessible via Pin 6. The 3-5V Trigger Switch (FIG. 13) has two selections; High and Off. When the 3-5V Trigger Switch is set to High, the amplifier will turn on when AC mains is turned on, unless the 12V trigger is forced High (it is default Low) through the 12V Trigger Input pin on the Control Input Connector (pin 3). For example, the 3-5V Trigger switch could be set to High if the amplifier needs to be forced on without having signal sense or external trigger signals.
7	Thermal	The Thermal Overload Indicator (OUT) signal can be used to send a Thermal message from the ALR-AMP-8 to an external controller (such as NetLinx Central Controller), if desired.
8	OC	The OC (Overcurrent) Monitor Indicator (OUT) signal can be used to send an OC message from the ALR-AMP-8 to an external controller if desired.
9	On signal, 12V Trigger	On Signal Output: Pin 9 provides a continuous 12VDC when the ALR-AMP-8 exits Standby Mode for On. When the ALR-AMP-8 is in Standby mode, Pin 9 falls to zero. When connected to an external Controller, this pin allows the Controller to be aware of the On/Off state of the ALR-AMP-8. For Signal Output, Pin 9 connects to an I/O pin on an external controller such as a NetLinx Central Controller. Note: Refer to AMX Tech Note #777 for details regarding configuring the I/O ports on a NetLinx Master to accept a voltage input. 12V Trigger: Pin 9 also functions as a 12V on/off output trigger. In this case, it can be used to turn on or off other amplifiers, when there are multiple Alero systems in an installation. As a 12V Trigger, Pin 9 connects to Pin 3 (12V Trigger Input) on a downstream ALR-AMP-8
10	GND	Ground reference for the Output pins (7-9) - required for any device that needs to sense the potential. Pin 10 connects to the GND pin of an I/O port on an external controller, such as a NetLinx Central Controller.

Applying Power to the ALR-AMP-8

! This unit should only have one source of incoming power. Using more than one source of power to the ALR-AMP-8 can result in damage to the internal components and a possible burn out.

! Apply power to the unit only after installation is complete.

1. Connect a standard IEC 3-pole detachable power cord to the AC Mains power connector on the rear panel.
2. Plug the attached power plug into a correctly grounded wall outlet.
3. Switch the Mains Power Switch (on the rear panel) to the On position.

Entering Standby Mode

1. Remove signal from the signal sense input, or disable signal sense input.
2. Enable 3-5V trigger -> Disable 3-5V trigger

Note that the POWER LED on the front panel lights Red to indicate that the amplifier is receiving power, but is in Standby mode. Also note that when in Standby mode, the 12V output trigger is turned off.

Note: Refer to the Alero ALR-AMP-8 Instruction Manual for more detailed product information.

For full warranty information, refer to the AMX Instruction Manual(s) associated with your Product(s).

