

REVISION HISTORY			
DATE	REV.	DESCRIPTION	BY
2023/8/17	A	INITIAL RELEASE	PXiong

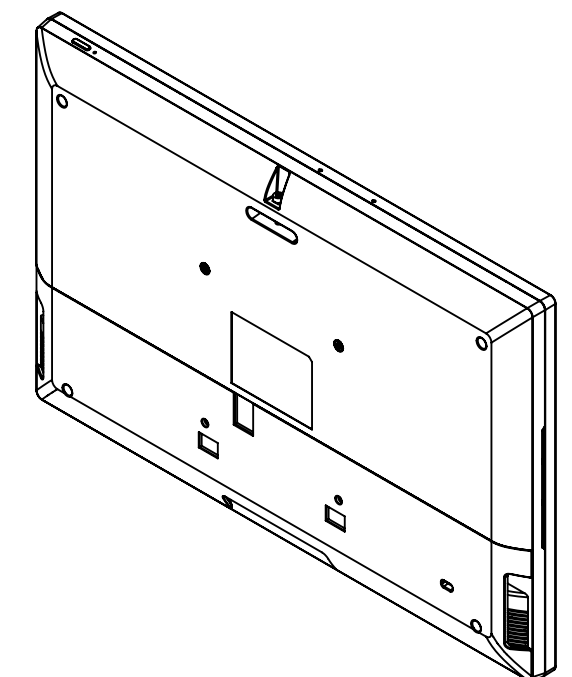
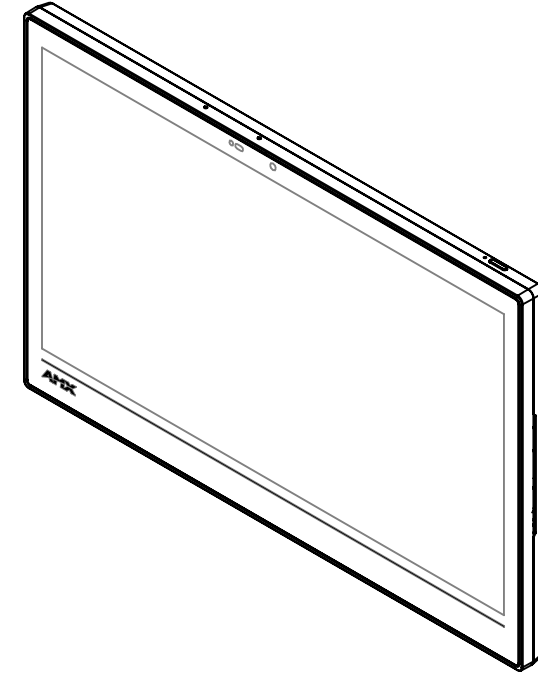
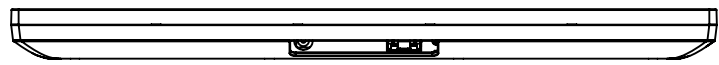
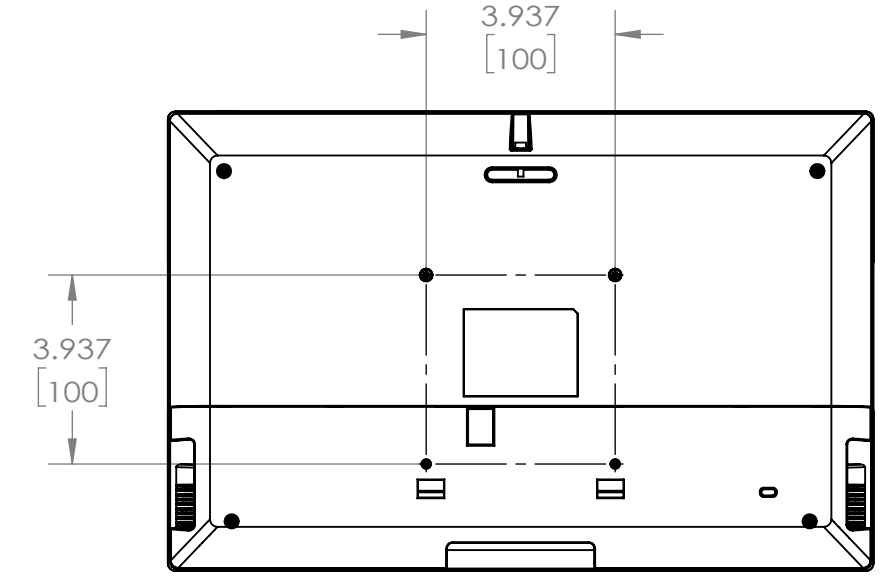
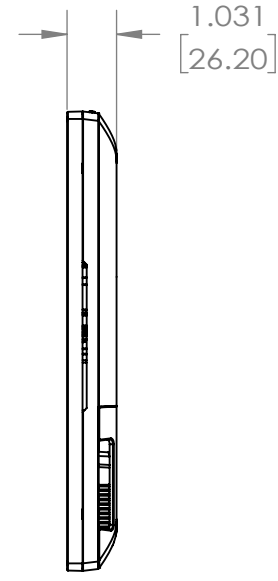
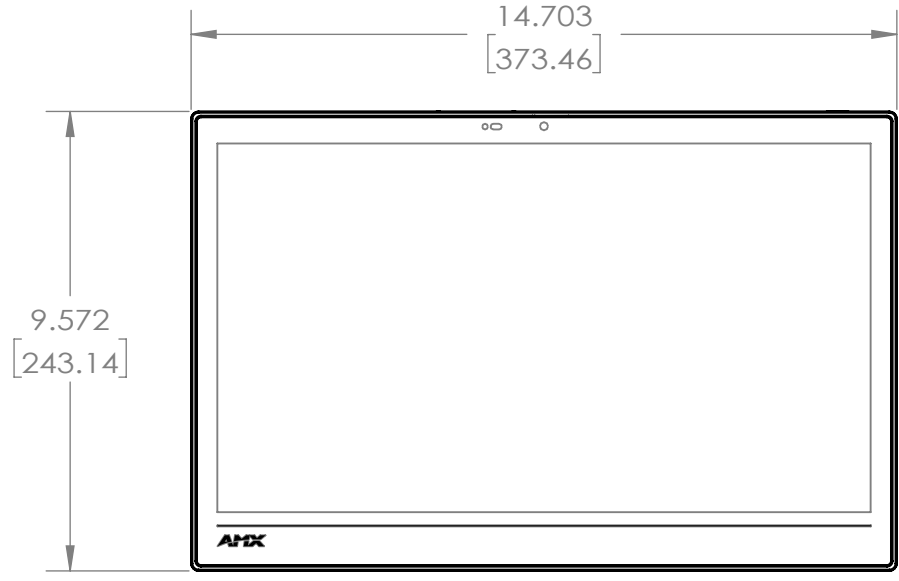

NOTES:
 1. Unit: inch / [mm]
 2. Detailed dimension refer to DXF/DWG files

2023 © HARMAN INTERNATIONAL INDUSTRIES, INCORPORATED. ALL RIGHTS RESERVED. DO NOT USE, DISCLOSE, SELL, REPRODUCE, PUBLISH OR MODIFY WITHOUT AUTHORIZED WRITTEN HARMAN PERMISSION.

ROHS
 RESTRICTION OF HAZARDOUS SUBSTANCES ALL MATERIALS USED IN THIS PART MUST BE ROHS COMPLIANT. SUPPLIER SHALL PROVIDE A CERTIFICATE OF ROHS COMPLIANCE WITH THE FIRST ARTICLE.

THIRD ANGLE PROJECTION

DRAWN BY: PXiong
 DATE: 2023/8/17

DESIGNED BY: _____
 DATE: _____

PROJECT MANAGER/ENGINEER: _____

DATE: 2023/8/17

DATE: _____

HARMAN

TITLE: DWG, PICTORIAL, AMX-UTP1511

NO. AMX-UTP1511 REV A

SIZE B SCALE 1:4 DO NOT SCALE DRAWING SHEET 1 OF 1